

Workshop and repair manual

VOLVO

ENGINE

**TAD 1640 & 1641 & 1642 GE
TAD 1641 & 1642 VE**

Workshop Manual

Group 20 Technical Data

| |
|-------------|
| I |
| 1(0) |

**TAD1640GE, TAD1641GE, TAD1642GE
TAD1641VE, TAD1642VE**

Technical data

Engine

TAD1640GE, TAD1641GE, TAD1642GE TAD1641VE, TAD1642VE

Contents

| | |
|-----------------------------------|-----------|
| Safety information | 2 |
| General information | 5 |
| Technical data | |
| General | 6 |
| Engine | 6 |
| Valve mechanism | 8 |
| Timing gear | 11 |
| Reciprocating components | 13 |
| Lubrication and oil systems | 16 |
| Fuel system | 18 |
| Inlet and exhaust system | 19 |
| Cooling system | 20 |
| Engine control system | 21 |
| Tightening torque | 22 |

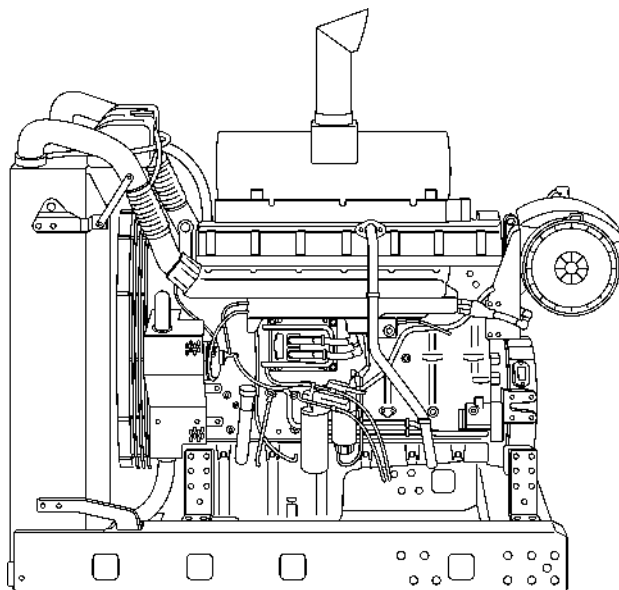



Safety information

This workshop manual contains technical data, descriptions and repair instructions for the Volvo Penta products or product versions noted in the table of contents. Check that you have the correct Workshop Manual for your engine.

Important

In this book and on the product you will find the following special warning symbols.

 **WARNING!** Possible danger of personal injury, extensive damage to property or serious mechanical malfunction if the instructions are not followed.

 **IMPORTANT!** Used to draw your attention to something that can cause damage or malfunctions on a product or damage to property.

NOTE: Is used to call attention to important information, to facilitate work processes or operations.

To give you a perspective of the risks which always need to be observed and precautions which always have to be taken, we have noted them below.

 Immobilize the engine by turning off the power with the main switch(es) and locking it (them) in the off position before starting service work. Fix a warning notice at the engine control point.

 All service work should normally be done on a stationary engine. Some work however, such as adjustments, needs the engine running. Approaching an engine which is operating is a safety hazard. Remember that loose clothing or long hair can fasten in rotating parts and cause serious personal injury.

If work is done adjacent to a running engine, a careless movement or a dropped tool can lead, in the worst case, to personal injury. Take care to avoid contact with hot surfaces (exhaust pipes, Turbocharger (TC), air intake pipe, starter heater etc.) and hot liquids in lines and hoses on an engine which is running or which has just been stopped. Reinstall all protective parts removed during service operations before starting the engine.

Read the available safety information, “General information” and “Repair instructions” in the workshop manual before you start to do any service work.

 Check that the warning or information labels on the product are always clearly visible. Replace labels which have been damaged or painted over.











 Never start the engine without the air cleaner filter fitted. The rotating compressor turbine in the turbocharger can cause severe injury. Foreign objects entering the intake ducts can also cause mechanical damage.







 Never use start spray or similar products to aid starting. They may cause an explosion in the inlet manifold. Danger of personal injury.

 Only start the engine in a well-ventilated area. When operated in a confined space, exhaust fumes and crankcase gases must be ventilated from the engine bay or workshop area.

 Avoid opening the coolant filler cap when the engine is hot. Steam or hot coolant can spray out and the system pressure will be lost. When needed, open the filler cap slowly and release the pressure in the system. Be extremely careful if a tap, plug or coolant hose has to be removed from a hot engine. It is difficult to anticipate in which direction steam or hot coolant can spray out.

 Hot oil can cause burns. Avoid getting hot oil on the skin. Ensure that the lubrication system is not under pressure before carrying out any work on it. Never start or operate the engine with the oil filler cap removed, otherwise oil could be ejected.

-  Stop the engine before carrying out operations on the engine cooling system.
-  Always use protective glasses or goggles when carrying out work where there is a risk of splinters, grinding sparks, acid splashes or where other chemicals are used. Your eyes are extremely sensitive, injury could cause blindness!
-  Avoid getting oil on the skin! Repeated exposure to oil or exposure over a long period can result in the skin becoming dry. Irritation, dryness, eczema and other skin problems can then occur. Used oil is more dangerous than fresh oil from a health aspect. Use protective gloves and avoid oil soaked clothes and shop rags. Wash regularly, especially before eating. There are special skin creams which counteract drying out of the skin and make it easier to clean off dirt after work is completed.
-  Most chemicals intended for the product (e.g. engine and transmission oils, glycol, gasoline and diesel oil) or chemicals for workshop use (e.g. degreasers, paints and solvents) are hazardous. Read the instructions on the product package carefully! Always follow the safety precautions for the product (for example use of breathing mask, eye protection, gloves etc.). Make sure that other personnel are not unknowingly exposed to hazardous chemicals, for example via the air. Ensure good ventilation in the work place. Follow the instructions provided when disposing of used or leftover chemicals.
-  Exercise extreme care when leak detecting on the fuel system and testing the fuel injector nozzles. Use eye protection. The jet from a fuel injector is under very high pressure, and has considerable penetration ability; fuel can force its way deep into body tissues and cause serious damage. Danger of blood poisoning (septicemia).
-  **WARNING!** The injector pipes must under no circumstances be bent or reshaped. Damaged pipes must be replaced.
-  All fuels, and many chemicals, are flammable. Do not allow naked flame or sparks in the vicinity. Certain thinner products and hydrogen from batteries are easily ignitable and are explosive when mixed with air in the right proportions. No Smoking! Ensure that the work area is well ventilated and take the necessary safety precautions before starting welding or grinding work. Always ensure that there are fire extinguishers at hand when work is being carried out.
-  Make sure that oil and fuel soaked rags, and used fuel and oil filters are stored in a safe place. Rags soaked in oil can spontaneously ignite under certain circumstances. Used fuel and oil filters are polluting waste and must be handed to an approved waste management facility for destruction, together with used lubrication oil, contaminated fuel, paint residue, solvents, degreasers and wash residue.
-  Never expose a battery to naked flame or electrical sparks. Never smoke close to the batteries. The batteries give off hydrogen gas during charging which when mixed with air can form an explosive gas - oxyhydrogen. This gas is easily ignited and highly explosive. A spark, which can be formed if the batteries are wrongly connected, is enough to make a battery explode and cause damage. Do not shift the connections when attempting to start the engine (spark risk) and do not lean over any of the batteries.
-  Always ensure that the Plus (positive) and Minus (negative) battery cables are correctly installed on the corresponding terminal posts on the batteries. Incorrect installation can result in serious damage to the electrical equipment. Refer to the wiring diagram.
-  Always use protective goggles when charging and handling the batteries. Battery electrolyte contains sulfuric acid which is highly corrosive. Should the battery electrolyte come into contact with unprotected skin wash off immediately using plenty of water and soap. If you get battery acid in your eyes, flush at once with a generous amount of water, and get medical assistance at once.
-  Stop the engine and turn off the power at the main switch(es) before carrying out work on the electrical system.

-  The clutch must be adjusted with the engine stationary.
-  Use the lifting eyes fitted on the engine when lifting the drive unit. Always check that the lifting equipment used is in good condition and has the load capacity to lift the engine (engine weight including gearbox, if fitted, and any extra equipment installed).
Use an adjustable lifting beam, or lifting beam specifically for the engine, to raise the engine to ensure safe handling and to avoid damaging engine parts installed on the top of the engine. All chains and cables should run parallel to each other and as perpendicular as possible in relation to the top of the engine.
If other equipment connected to the engine has altered its center of gravity, special lifting devices may be needed to obtain the correct balance and safe handling.
Never carry out work on an engine suspended on a hoist.
-  Never work alone when heavy components are to be dismantled, even when safe lifting devices such as lockable blocks & tackle are used. When using a lifting device two people are usually required to do the work, one to take care of the lifting device and another to ensure that components are lifted clear and not damaged during the lifting operations.
Always make sure that there is enough space for disassembly where you are working, with no risk for personal or material damage.
-  **WARNING!** The components in the electrical system and in the fuel system on Volvo Penta products are designed and manufactured to minimize the risk of fire and explosion. The engine must not be run in areas where there are explosive materials.
-  Always use fuels recommended by Volvo Penta. Refer to the Instruction Book. Use of fuels that are of a lower quality can damage the engine. On a diesel engine poor quality fuel can cause the control rod to seize and the engine to overrev with resulting risk of damage to the engine and personal injury. Poor fuel quality can also lead to higher maintenance costs.
-  Remember the following when washing with a high pressure washer: Never aim the water jet at seals, rubber hoses or electrical components. Never use a high pressure washer for engine cleaning.
-  The injectors can leak fuel when the engine is stationary, if the tank is higher than the engine and the fuel pressure is positive.

General information

About this Workshop Manual

This workshop manual contains engine descriptions and repair instructions for the standard versions of TAD1640GE, TAD1641GE, TAD1642GE, TAD1641VE and TAD1642VE engines.

The workshop manual, Technical data section, contains specifications and tightening torques for the standard versions of TAD1640GE, TAD1641GE, TAD1642GE, TAD1641VE and TAD1642VE engines. This document contains all the references from the Workshop manual.

The Engine Designation and Engine Numbers can be found on the product plate.

Please always include both the engine designation and the engine number in all correspondence.

The Workshop Manual is produced primarily for the use of Volvo Penta workshops and qualified Volvo service technicians. For this reason the manual presupposes a certain basic knowledge and that the user can carry out the mechanical/electrical work described to a general standard of engineering competence.

Volvo Penta products are under a continual process of development and we therefore reserve all rights regarding changes and modifications. All the information in this manual is based on product specifications available at the time the book was published. Any material changes introduced into the product or service methods after this date are notified by means of Service Bulletins.

Spare parts

Spare parts for the electrical and fuel systems are subject to various national safety requirements. Volvo Penta Original Spares comply with these requirements. No damage whatever, occasioned by use of non-original Volvo Penta spares for the product, will be compensated by the warranty offered by Volvo Penta.

Certified engines

The manufacturer certifies that both new engines and those in use, which are certified for national or regional legislation, comply with the environmental requirements. The following requirements for service and spare parts must be complied with, for Volvo Penta as a manufacturer to be responsible for ensuring that engines in use comply with the stipulated environmental requirements:

- Maintenance and service intervals recommended by Volvo Penta must be complied with.
- Only Volvo Penta Original Spare Parts intended for the certified engine version may be used.
- Service related to injection pumps, pump settings and injectors must always be done by an authorized Volvo Penta workshop.
- The engine must not be converted or modified in any way, except for the accessories and service kits which Volvo Penta has approved for the engine.
- Installation changes to the exhaust pipe and the engine bay air inlet ducts (ventilation ducts) must not be done without further discussion, since this could affect exhaust emissions.
- No tamper-seals may be broken by unauthorized personnel.

The general advice in the instruction book about operation, care and maintenance, applies.

 **IMPORTANT!** When spare parts are needed, use only Volvo Penta Original Spares.

The use of non-original spare parts means that AB Volvo Penta can no longer be responsible for guaranteeing that the engine complies with the certified version.

Any damage, injury and/or costs which arise due to the use of non-original Volvo Penta spares for the product in question will not be compensated by Volvo Penta.

Technical data

General

| Designation | TAD1640GE | TAD1641GE | TAD1642GE | TAD1641VE | TAD1642VE |
|----------------------------------|----------------------|-------------|-------------|-------------|-------------|
| Power, Prime/Stand-by | See sales literature | | | | |
| Torque, Prime/Stand-by | See sales literature | | | | |
| No. of cylinders | 6 | 6 | 6 | 6 | 6 |
| Bore | 144 | 144 | 144 | 144 | 144 |
| Stroke, mm | 165 | 165 | 165 | 165 | 165 |
| Cylinder volume, dm ³ | 16,12 | 16,12 | 16,12 | 16,12 | 16,12 |
| Weight, dry (kg) | 1440 | 1440 | 1480 | 1480 | 1480 |
| Weight, wet (kg) | 1510 | 1510 | 1550 | 1550 | 1550 |
| Injection sequence | 1-5-3-6-2-4 | 1-5-3-6-2-4 | 1-5-3-6-2-4 | 1-5-3-6-2-4 | 1-5-3-6-2-4 |
| Compression-ratio | 17,5:1 | 16,5:1 | 16,5:1 | 17,5:1 | 17,5:1 |
| Low idle, rpm | 900 | 900 | 900 | 600 | 600 |
| High idle, rpm | 1500/1800 | 1500/1800 | 1500/1800 | 1800-2000 | 1800-2000 |

Engine

Engine block

Length 1156 mm (45.51")

Height, upper block plane - crankcase centerline ... 453 mm (17.83")

Height lower block plane - crankcase centerline 120 mm (4.72")

Crankcase pressure,

normal value, irrespective of engine speed max 0.5 kPa (0.07 psi)

Cylinder head

| | |
|--|---------------------|
| Type | 6 cyl |
| Length | 1194 mm (47.2") |
| Width | 438 mm (17.24") |
| Height | 135 mm (5.31") |
| Max. out-of-flatness (base plane)* | 0.02 mm (0.000787") |

*on 100 mm (3.937") measured length

Cylinder head bolts

| | |
|-------------------------|----------------|
| Number of bolts | 38 |
| Dimension, thread | M18 |
| Length | 188 mm (7.40") |

Cylinder liner

| | |
|--|-------------------------------------|
| Type | Wet, replaceable |
| Height, total. | 288 mm (11.34") |
| Sealing surface height above block plane | 0.15 - 0.21 mm (0.00612 - 0.00862") |
| No. of seal rings per cylinder liner | 3 |

Piston

| | |
|---------------------------------------|------------------------------------|
| Type | aluminum |
| Height above engine block plane | 0.15 - 0.65 mm (0.00612 - 0.0256") |
| Diameter, combustion chamber | 98 mm (3.86") |
| Depth, piston bowl: | |
| TAD1640GE | 19.35 mm (0.76") |
| TAD1641GE | 21.15 mm (0.83") |
| TAD1642GE | 21.15 mm (0.83") |
| TAD1641VE | 19.35 mm (0.76") |
| TAD1642VE | 19.35 mm (0.76") |
| No. of ring grooves | 3 |
| Front marking | Arrow towards front |
| Gudgeon pin diameter | 63 mm (2.48") |

Piston rings

Compression rings

| | |
|--|---|
| Specification | |
| Quantity | 2 |
| Piston ring clearance in groove: | |
| upper compression ring | - |
| lower compression ring | 0.07 mm (0.00276") Wear tolerance 0.1 mm (0.003937") |
| Piston ring gap, measured at ring opening: | |
| upper compression ring | 0.62 mm (0.00244") Wear tolerance 0.85 mm (0.003346") |
| lower compression ring | 1.1 mm (0.0433") Wear tolerance 1.35 mm (0.0531") |

Oil scraper ring

| | |
|---|---|
| Quantity | 1 |
| Width, incl. spring | 4.55 mm (0.179") |
| Piston ring clearance in groove, | 0.04 mm (0.00157") Wear tolerance 0.1 mm (0.00393") |
| Piston ring gap, measured at ring opening | 0.55 mm (0.0216") Wear tolerance 0.9 mm (0.00354") |

Valve mechanism

Valves

Valve head, diameter:

| | |
|---------------|---------------|
| Inlet | 49 mm (1.93") |
| Exhaust | 46 mm (1.81") |

Valve stem, diameter:

| | |
|---------------|----------------|
| Inlet | 10 mm (0.394") |
| Exhaust | 10 mm (0.394") |

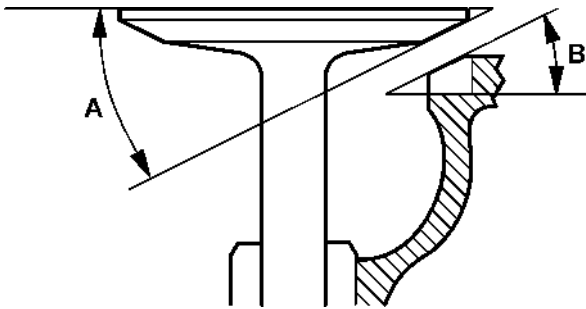

Valve seat angle (A):

| | |
|---------------|-------|
| Inlet | 19,5° |
| Exhaust | 44,5° |

Seat angle in cylinder head (B):

| | |
|---------------|-----|
| Inlet | 20° |
| Exhaust | 45° |

Dimension between valve head and cylinder head plane:

| | |
|---------------------------|---------------------------------|
| Inlet | 0.9 - 1.4 mm (0.0354 - 0.0551") |
| Wear tolerance, max | 1.5 mm (0.059055") |
| Exhaust | 1.4 - 1.9 mm (0.0551 - 0.0748") |
| Wear tolerance, max | 2.0 mm (0.07874") |

Note! When the valve seats are changed, the valves must be changed at the same time.

Valve clearance, cold engine, setting value:

| | |
|---------------|------------------|
| Inlet | 0.3 mm (0.0118") |
| Exhaust | 0.6 mm (0.0236") |

Valve clearance, cold engine, check value:

| | |
|---------------|-----------------------------------|
| Inlet | 0.25 -0.35 mm (0.00984 - 0.0138") |
| Exhaust | 0.55 -0.65 mm (0.0216 - 0.0256") |

Valve seats

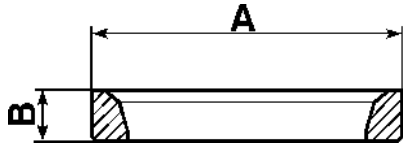

Outer diameter (A)

Standard:

- Inlet 52 mm (2.05")
- Exhaust 49 mm (1.93")

Oversize:

- Inlet 52.2 mm (2.06")
- Exhaust 49.2 mm (1.94")

Height (B):

- Inlet 7.7 mm (0.303")
- Exhaust 7.9 mm (0.311")

Valve seat bed

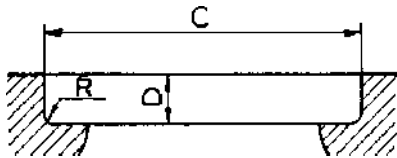

Diameter (C) standard:

- Inlet 52.0 mm (2.05")
- Exhaust 49.0 mm (1.93")

Diameter (C) oversize:

- Inlet 52.2mm (2.06")
- Exhaust 49.2 mm (1.94")

Depth (D):

- Inlet 11.7 mm (0.46")
- Exhaust 11.7 mm (0.46")

Seat base radius (R):

- Inlet max 0.8 mm (0.315")
- Exhaust max 0.8 mm (0.315")

Valve guides

Length:

| | |
|---------------|-----------------|
| Inlet | 83.5 mm (3.29") |
| Exhaust | 83.5 mm (3.29") |

Inner diameter:

| | |
|---------------|---------------|
| Inlet | 10 mm (0.39") |
| Exhaust | 10 mm (0.39") |

Height above cylinder head spring plane:

| | |
|---------------|-------------------------------|
| Inlet | 24.4 ± 1.0 mm (1.00 ± 0.157") |
| Exhaust | 24.4 ± 1.0 mm (1.00 ± 0.157") |

Clearance, valve stem - guide*:

| | |
|--------------------------|---------------------------------------|
| Inlet | 0.025 - 0.054 mm (0.00098 - 0.00213") |
| Wear tolerance max | 0.4 mm (0.01575") |
| Exhaust | 0.058 - 0.087 mm (0.00228 - 0.00342") |
| Wear tolerance max | 0.4 mm (0.01575") |

* The dimensions have been calculated for the method of measurement described in the workshop manual (Group 21).

Rocker arms

| | |
|-----------------------------------|-----------------------|
| Bearing clearance | max 0.1 mm (0.00394") |
| Clearance rocker arm roller | max 0.1 mm (0.00394") |

Valve springs

Inlet

| | |
|-------------------------------------|-----------------|
| Uncompressed length | 67.5 mm (2.66") |
| With 522 N (117.45 lbf) load | 57.0 mm (2.24") |
| With 1205 N (271.13 lbf) load | 43.3 mm (1.70") |
| Coilbound length, max | 40.3 mm (1.59") |

Exhaust

Outer valve springs:

| | |
|----------------------------------|----------------------|
| Uncompressed length | 69.3 mm (2.73") |
| With 930 N (209 lbf) load | 54.0 mm (2.13inches) |
| With 1813 N (408 lbf) load | 39.5 mm (1.56") |
| Coilbound length, max | 37.0 mm (1.46") |

Inner valve spring:

| | |
|---------------------------------|-----------------|
| Uncompressed length | 67.0 mm (2.64") |
| With 465 N (105 lbf) load | 51.0 mm (2.01") |
| With 887 N (200 lbf) load | 36.5 mm (1.44") |
| Coilbound length, max | 34.0 mm (1.34") |

Timing gear

Timing gear wheels

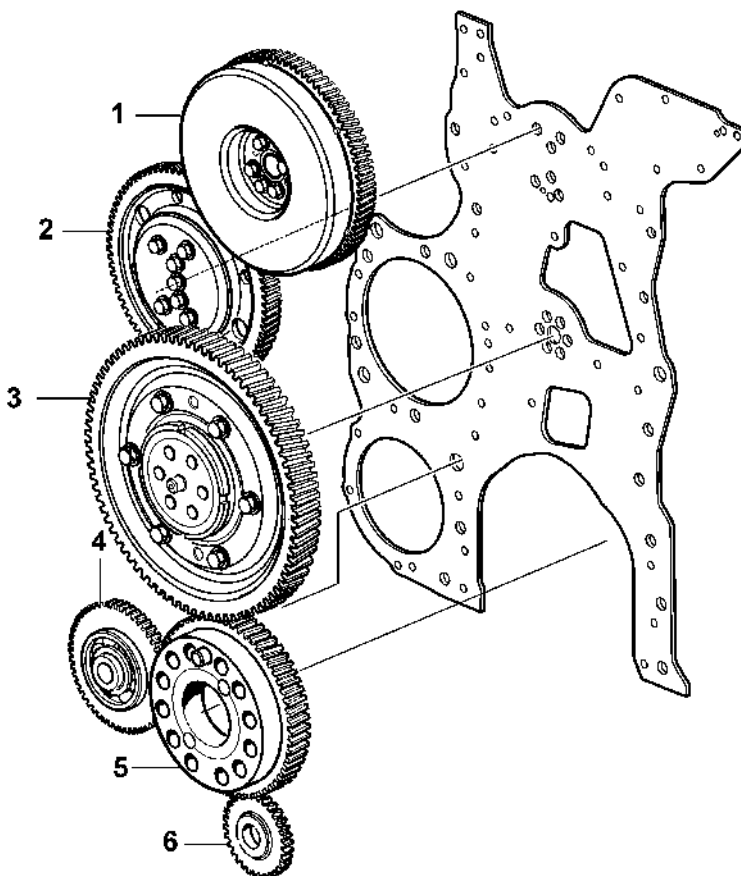

No. of teeth:

| | |
|--|----|
| 1 Drive gear, camshaft | 84 |
| 2 Idler wheel, adjustable | 85 |
| 3 Idler wheel, bull gear outer | 84 |
| Idler wheel, bull gear inner | 56 |
| 4 Idler wheel, servo pump | 29 |
| 5 Drive gear, crankshaft | 63 |
| 6 Drive gear, lube-oil pump | 37 |
| 7 Drive gear, steering servo and fuel feed pump | 36 |

| | |
|--|---|
| Flank clearance | 0.05-0.17 mm (0.00197 - 0.00669") |
| Shaft stub for idler wheel, diameter | Ø 99.97-99.9999.97 mm (3.9358 -3.9366") |
| Bushing for idler wheel, diameter | Ø 100.036-100.05 mm (3.9384-3.9567") |
| Radial clearance for idler wheel | max 0.05 mm (0.00197") |

Camshaft

Check camshaft setting, cold engine and valve clearance = 0.

Inlet valve for cylinder 1, with flywheel position 6 a.t.d.c. should be open 1.4 ± 0.3 mm (0.055 ± 0.012 ")

When performing the check, the timing gears must be rotated clockwise, when seen from the front, to take up all gear flank clearance.

Drive gear wheel

No of bearings 7

NOTE: Only check values, not for machining.

Diameter, bearing journals, standard 69.97 - 70.00 mm (2.755 - 2.759")

Diameter, bearing journals, undersize:

0,25 69.72 - 69.78 mm (2.749 - 2.747")

0,50 69.47 - 69.53 mm (2.735 - 2.737")

0,75 69.22 - 69.28 mm (2.725 - 2.727")

Max. end float 0.35 mm (0.0138")

Max permissible ovality (with new bearings) 0.05 mm (0.00197")

Bearing, max. permissible wear on diameter 0.05 mm (0.00197")

Valve lift:

inlet 13.7 mm (0.54")

exhaust 14.5 mm (0.57")

Permitted wear between base circle

and max lift max 0.1 mm (0.00394")

Unit injector, stroke 18 mm (0.71")

Camshaft bearings

Camshaft bearing thickness, standard 1.92 mm (0.076")

Oversize:

0,25 2.05 mm (0.080")

0,50 2.17 mm (0.085")

0,75 2.30 mm (0.090")

Reciprocating components

Crankshaft

| | |
|--|-------------------------|
| Length | 1256 mm (49.45") |
| Crankshaft, end float* | 0.15 mm (0.006") |
| Ovality of main and big end bearings | max 0.01 mm (0.000394") |
| Taper of main and big end bearings | max 0.02 mm (0.000787") |
| Runout on center bearing | 0.15 mm (0.006") |

* Dimensions refer to oiled components.

Main bearing journal

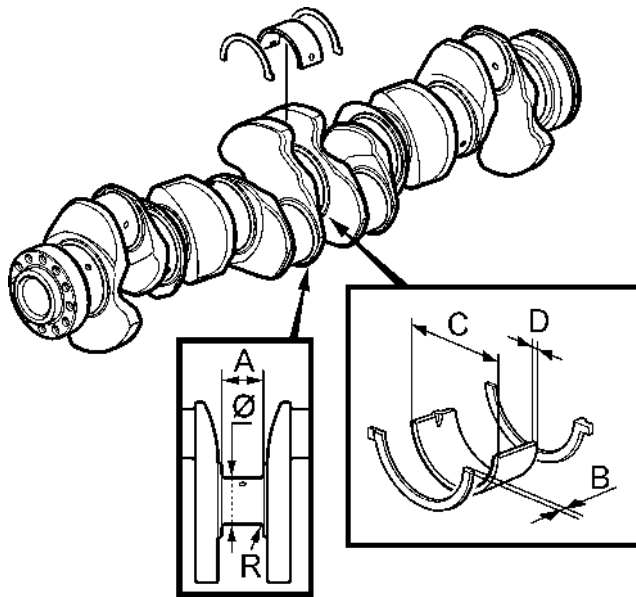

NOTE! Only check values, not for machining.

| | |
|--|--------------------|
| Diameter (Ø) standard | 118.0 mm (4.65") |
| Undersize: | |
| 0.25 mm (0.01") | 117.75 mm (4.636") |
| 0.50 mm (0.0197") | 117.50 mm (4.626") |
| 0.75 mm (0.029") | 117.25 mm (4.616") |
| 1.00 mm (0.039") | 117.00 mm (4.61") |
| 1.25 mm (0.049") | 116.75 mm (4.596") |
| Surface finish, main bearing journal | Ra 0.25 |
| Surface finish, radius | Ra 0.4 |
| Width thrust bearing journal (A) standard | 49.0 mm (1.93") |
| Oversize: | |
| 0.2 mm (0.007874") (thrust bearing 0.003937") | 49.2 mm (1.937") |
| 0.4 mm (0.01575") (thrust bearing 0.007874") | 49.4 mm (1.945") |
| 0.6 mm (0.0236") (thrust bearing 0.0118") | 49.6 mm (1.952") |
| Web flank radius (R) | 4.5 mm (0.197") |

Thrust washers (thrust bearing)

Width **(B)** standard 3.18 mm (0.125")

Oversize:

0.1 mm (0.004") 3.28 mm (0.129")
 0.2 mm (0.008") 3.38 mm (0.133")
 0.3 mm (0.012") 3.48 mm (0.137")
 0.4 mm (0.016") 3.58 mm (0.140")

Main bearing shells

Outer diameter **(C)** 123.12 mm (4.847")

Thickness **(D)** standard 2.51 mm (0.099")

Oversize:

0.25 mm (0.0098") 2.64 mm (0.104")
 0.50 mm (0.0197") 2.76 mm (0.109")
 0.75 mm (0.0295") 2.89 mm (0.114")
 1.00 mm (0.039") 3.01 mm (0.118")
 1.25 mm (0.049") 3.14 mm (0.124")

Radial clearance, main bearings 0.07-0.14 mm (0.00275 - 0.00550")

Big end bearing journal

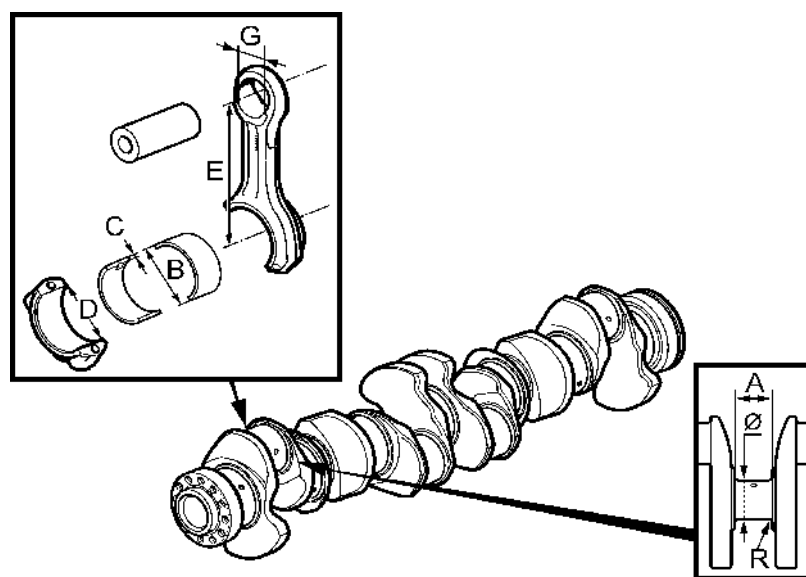

Note! Only check values, not for machining.

Diameter **(Ø)** 112 mm (4.409")

Undersize:

0.25 mm (0.0098") 111.75 mm (4.40")
 0.50 mm (0.0197") 111.50 mm (4.3897")
 0.75 mm (0.0295") 111.25 mm (4.380")
 1.00 mm (0.039") 111.00 mm (4.370")
 1.25 mm (0.049") 110.75 mm (4.360")

Surface finish, big end bearing journal. Ra 0.25

Surface finish, radius Ra 0.4

Width **(A)** 60mm (2.36")

Web flank radius **(R)** 4.5 mm (0.177")

Big end journal shells

| | |
|--|-------------------|
| Outer diameter (B) | 116,8 mm (4.598") |
| Thickness (C) standard | 2.35 mm (0.092") |
| Oversize: | |
| 0.25 mm (0.098") | 2.48 mm (0.098") |
| 0.50 mm (0.0197") | 2.60 mm (0.102") |
| 0.75 mm (0.029") | 2.73 mm (0.107") |
| 1.00 mm (0.039") | 2.85 mm (0.112") |
| 1.25 mm (0.049") | 2.98 mm (0.117") |
| Diameter, bearing shell seat (D) | 116,8 mm (4.598") |

Connecting rod

| | |
|---|----------------------|
| Length, center - center (E) | 280 mm (11.02") |
| Gudgeon pin bush internal diameter (G) | 63 mm (2.48") |
| End float, connecting rod - crankshaft ¹ : | max 0.35 mm (0.014") |
| Big end bearing, radial clearance ¹ : | max 0.10 mm (0.004") |
| Straightness, max. deviation on 100 mm (3.937") | |
| measured length | 0.06 mm (0.0024") |
| Twist, max. deviation on 100 mm (3.937") | |
| measured length | 0.15 mm (0.006") |

¹ Dimensions refer to oiled components.

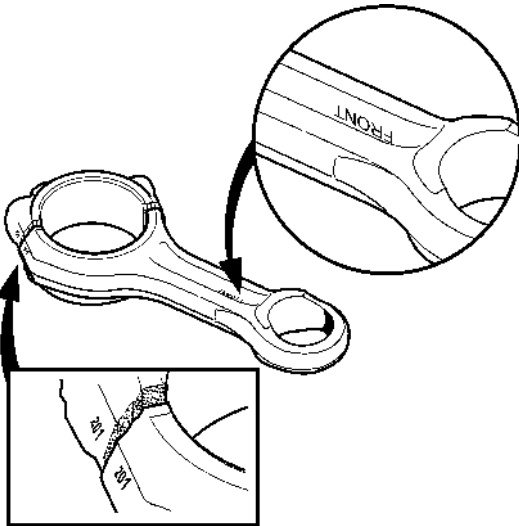

Marking:

“FRONT” on the connecting rod faces forwards.

The connecting rods and caps are marked in pairs, using a three digit serial number (please refer to the illustration).

Flywheel, installed

| | |
|--|---------------------|
| Runout, measured radius 150 mm (5.90") | max 0.1 mm (0.004") |
| No. of teeth on starter gear ring | 153 |
| Sensor grooves in flywheel | 54 |

Flywheel housing, installed

| | |
|---|----------------------|
| Runout for mating face against bellhousing. | max 0.1 mm (0.004") |
| Radial runout for alignment against bellhousing. | max 0.05 mm (0.002") |

Lubrication and oil systems

Oil

Oil change volume, incl filters 48 liter (50.7 US quart)

Oil pressure

Operating speed (above 1100 rpm) 300 -650 kPa (43.5-94.25 psi)

Low idle min 160 kPa (23.2 psi)

Oil temperature

Cold engine ambient temperature

Hot engine max 125°C (257°F)

Lube oil pump

Type Gear driven

No. of teeth, drive wheel 37

Flank clearance 0.05-0.40 mm (0.002 - 0.016")

Oil filter

Full flow filter 2

Turbofilter (Bypass filter) 1

Oil valves

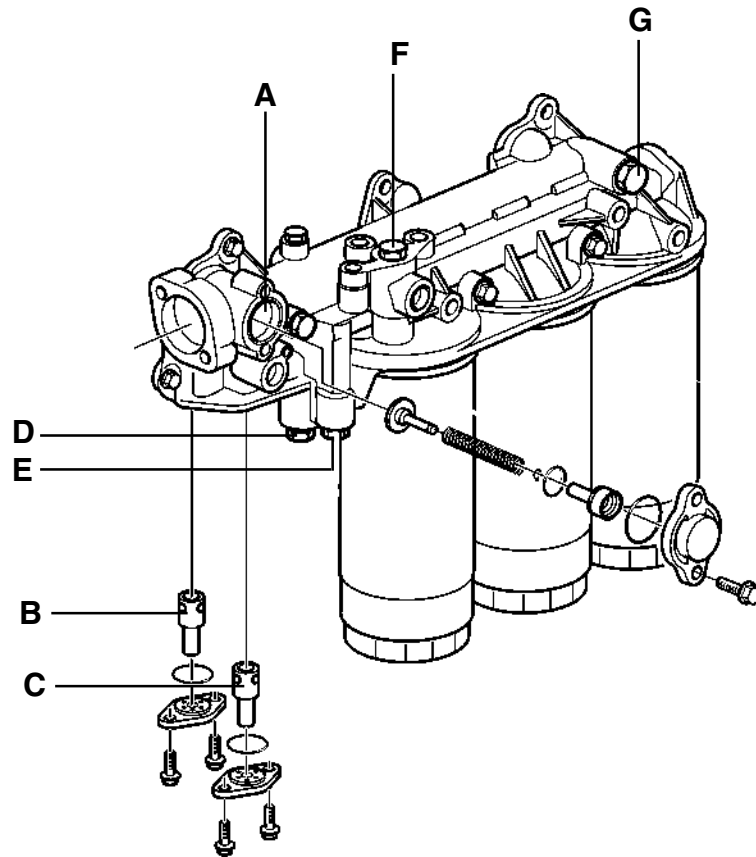

- A: Bypass valve, oil cooler**
 Spring, free length 69 mm (2.72")
 Loaded 13-15 N (2.9-3.4 lbf) 40 mm (1.57")

- B: Safety valve, lube oil pump**
 Marking Violet

- C: Reduction valve, oil pressure**
 Marking Blue

- D: Control valve, piston cooling**
 Spring, free length 122 mm (4.80")
 Loaded, 60 N (13.4 lbf) 84 mm (3.31")

- E: Opening valve, piston cooling**
 Spring, free length 122 mm (4.80")
 Loaded, 95 N (21.4 lbf) 63 mm (2.48")

- F: Bypass valve, bypass filter**
 Spring, free length 69 mm (2.72")
 Loaded 13-15 N (2.9-3.4 lbf) 40 mm (1.57")

- G: Bypass valve, full flow filter**
 Spring, free length 69 mm (2.72")
 Loaded 13-15 N (2.9-3.4 lbf) 40 mm (1.57")

Fuel system

Feed pump

Feed pressure at:

- 600 rpm min 100 kPa (14.5 psi)
- 1200 rpm min 300 kPa (43.5 psi)
- full load min 300 kPa (43.5 psi)

Bypass valve

Opening pressure 400 - 550 kPa (58 - 80 psi)

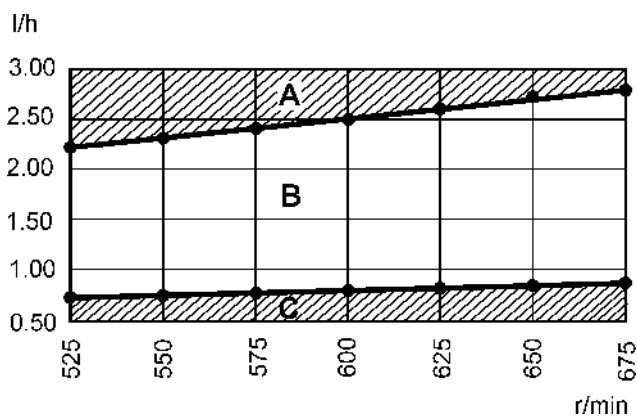

Fuel quantity

At low idle and with the engine unloaded, the fuel quantity should be inside area B. The engine should be run in at least 600 h.

Unit injector

Pre-load 3-4 spanner flats (0.75 ± 0.1 mm (0.030 - 0.0040")), please refer to the illustration.

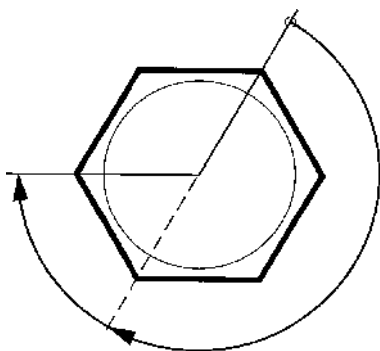

Tighten the adjustment screw to zero clearance against the camshaft, then turn 3-4 spanner flats.

Inlet and exhaust system

Turbocharger

Manufacturer/type I3K/K29
End float, turbine shaft max 0.13 mm (0.005")

Inlet temperature indicator

Cold engine Ambient temperature
Hot engine, coolant temperature 75-95°C
(167-203°F) max 30°C above ambient temperature

Pressure drop indicator

Pressure drop indicator warns
at a pressure drop of 5 kPa (37.5 mm VP) (0.725 psi)

Boost pressure

TAD1640GE 231 kPa (33.1 psi)
TAD1641GE 265 kPa (38.3 psi)
TAD1642GE 273 kPa (39,6 psi)

TAD1641VE 193 kPa (28.0 psi)
TAD1642VE 225 kPa (32.6 psi)

Cooling system

General

Pressure cap opens at 75 kPa (10.8 psi)

Thermostat

Quantity 1
 Opening temperature 86°C (186.80°F)
 Fully open 96°C (205°F)

Coolant

Type Volvo Original
 Consists of Glycol and corrosion-inhibiting additives
 Color Green
 Mix with Tap water

Corrosion protection

Only used when anti-freeze is not needed.

Type Volvo Original
 Mix with Tap water

NOTE: The corrosion inhibitor must not be mixed with other types of coolants or corrosion inhibitors, since this can have adverse effects.

Engine control system

Engine control unit

No. of pins 2 x 36

Sensor

Charge pressure sensor

Check value 1.05 - 1.30 V at 100 kPa (14.5 psi)

Camshaft sensor

Distance to camshaft 1.1 ±0.4 mm (0.0433 - 0.0157")

Flywheel sensor

Distance to flywheel 1.1 ±0.4 mm (0.0433 - 0.0157")

Pressure drop indicator

Active V = 0.48 x Ubat

Inactive V = 0.12 x Ubat

Charge air temperature sensor

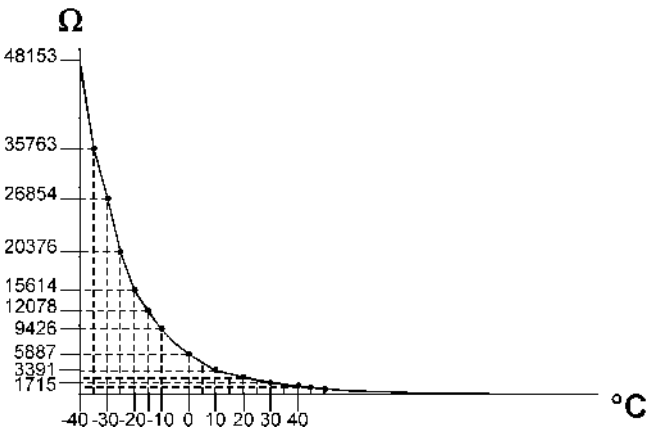

Coolant temperature sensor

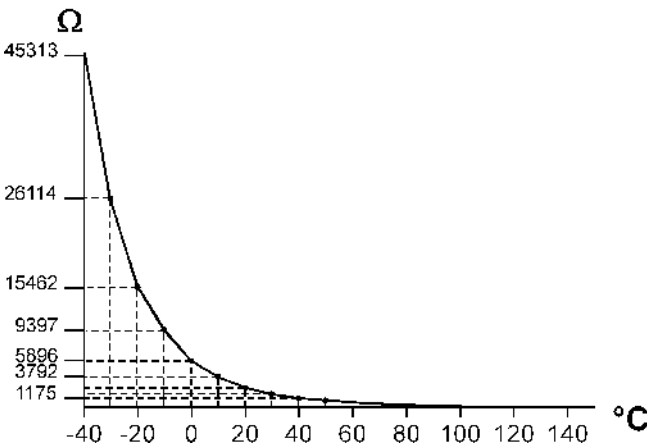

Engine oil temperature sensor

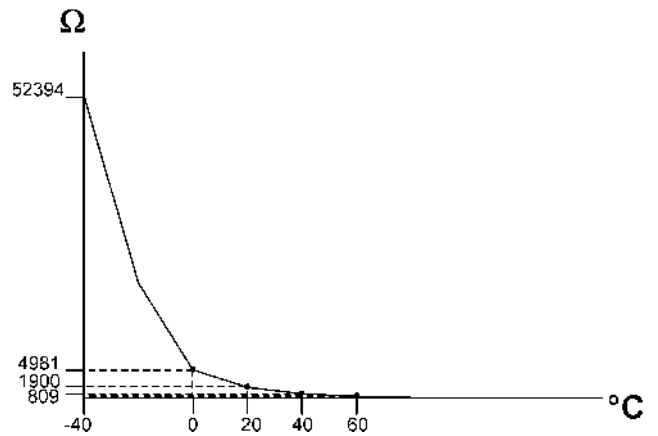

Tightening torque

General tightening torques

| | |
|------------------------------|-------------------------------|
| M6 standard screw 8.8 | 10 ± 1.5 Nm (7.4 ± 1 lbf ft) |
| M8 standard screw 8.8 | 25 ± 4 Nm (18.5 ± 3 lbf ft) |
| M10 standard screw 8.8 | 50 ± 8 Nm (37 ± 6 lbf ft) |
| M12 standard screw 8.8 | 85 ± 15 Nm (63 ± 11 lbf ft) |
| M14 standard screw 8.8 | 140 ± 25 Nm (103 ± 18 lbf ft) |
| M16 standard screw 8.8 | 220 ± 35 Nm (162 ± 26 lbf ft) |

Only torqued screws can be re-installed.

Torque and angle tightened / plastic limit tightened screws:

- 8.8 should not be re-installed
- 10.9 can be re-installed
- 12.9 can be re-installed

IMPORTANT! Check screws which are to be re-installed. Damaged screws, with marks of seizure etc. under the heads, must be scrapped.

Tightening torque, group 21: Engine body

| | |
|--|-------------------------------|
| Front engine mounting, engine block | 220 ± 35 Nm (162 ± 26 lbf ft) |
| Front engine mounting | 220 ± 35 Nm (162 ± 26 lbf ft) |
| Rear engine mounting, flywheel housing | 220 ± 35 Nm (162 ± 26 lbf ft) |

Main bearing caps

- stage 1 300 ± 20 Nm (220 ± 15 lbf ft)
- stage 2 120° ± 5° angle tightening

Big end bearing cap

- stage 1 20 ± 3 Nm (15 ± 2 lbf ft)
- stage 2 60 ± 5 Nm (44 ± 4 lbf ft)
- stage 3 90° ± 5° angle tightening

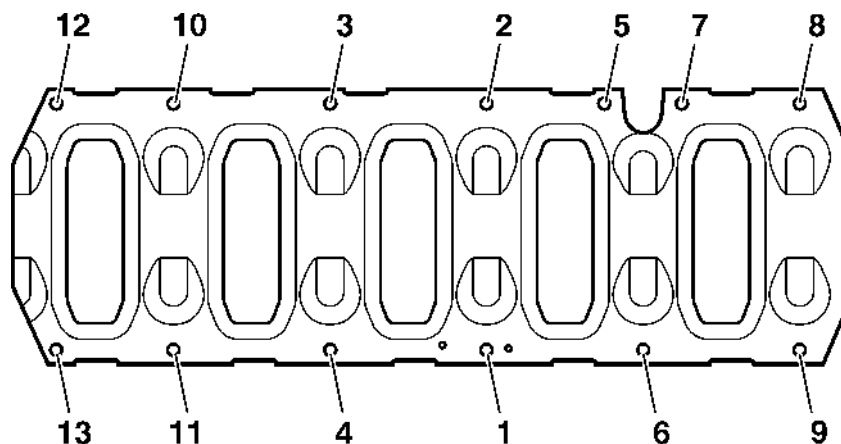

Stiffening frame

NOTE: Tighten in number order, as in the illustration.

- stage 1 65 ± 5 Nm (48 ± 4 lbf ft)
- stage 2 60° ± 5° angle tightening

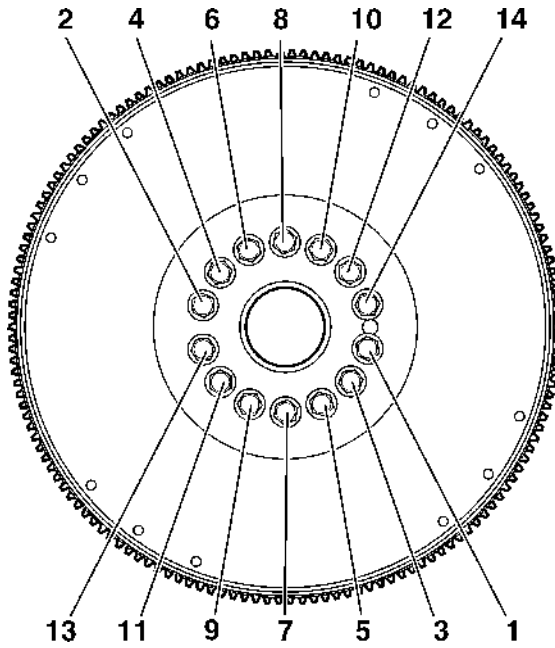

Flywheel

NOTE: Make sure that the flange is clean and dry.

NOTE: Tighten the screws in number order, as in the illustration.

stage 1 60 ± 5 Nm (44 ± 4 lbf ft)

stage 2 120° ± 10° angle tightening

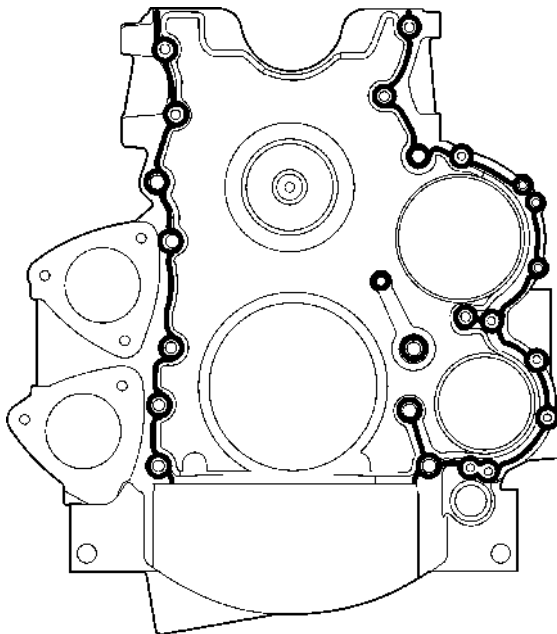

Flywheel housing

NOTE: Apply 2 mm (approx 1/8 inch) silicone sealer as in the illustration.

stage 1: Torque all M14 screws to 160 ± 20 Nm (118 ± 15 lbf ft)

stage 2: Torque all M10 screws to 48 ± 8 Nm (35 ± 6 lbf ft)

stage 3: Torque all M8 screws to 24 ± 4 Nm (18 ± 3 lbf ft)

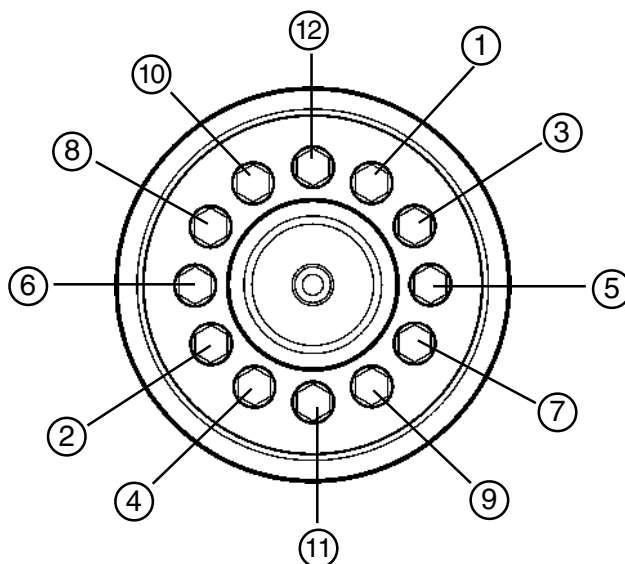
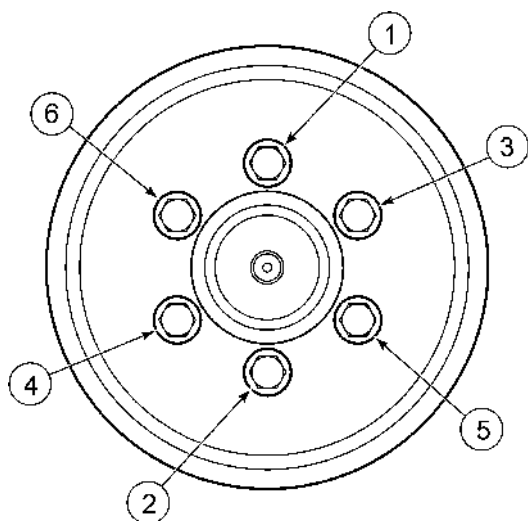

Vibration damper 90 ±10 Nm (66 ± 7 lbf ft)

NOTE: Tighten the screws in number order, as in the illustration.

The 8.8 screws on the vibration damper must **not** be re-used.

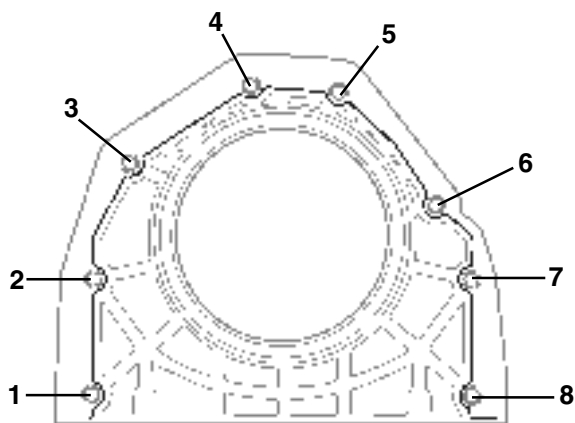

Housing, crankcase seal

NOTE: Apply 2 mm (approx 1/8 inch) silicone sealer as in the illustration.

stage 1: Tighten all screws by hand.

stage 2: Torque screws “2” and “7” to 24 ± 4 Nm (18 ± 3 lbf ft)

stage 3: Torque the remaining screws to 24 ± 4 Nm (18 ± 3 lbf ft)

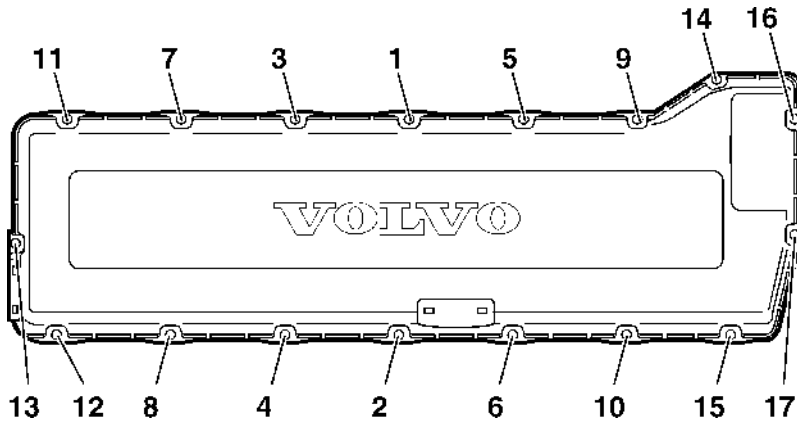

Valve cover 25 ±3 Nm (18.5 ± 2 lbf ft)

NOTE: Tighten the screws in number order, as in the illustration.

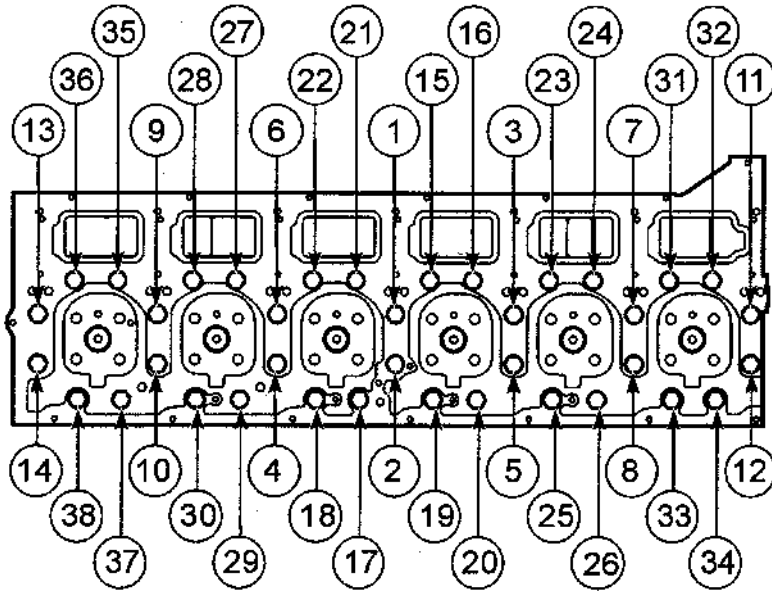

Cylinder head

NOTE: Tighten the screws in number order, as in the illustration.

- stage 1 60 ⁺¹⁰/₀ Nm
- stage 2 90° ±5° angle tightening
- stage 3 90° ±5° angle tightening

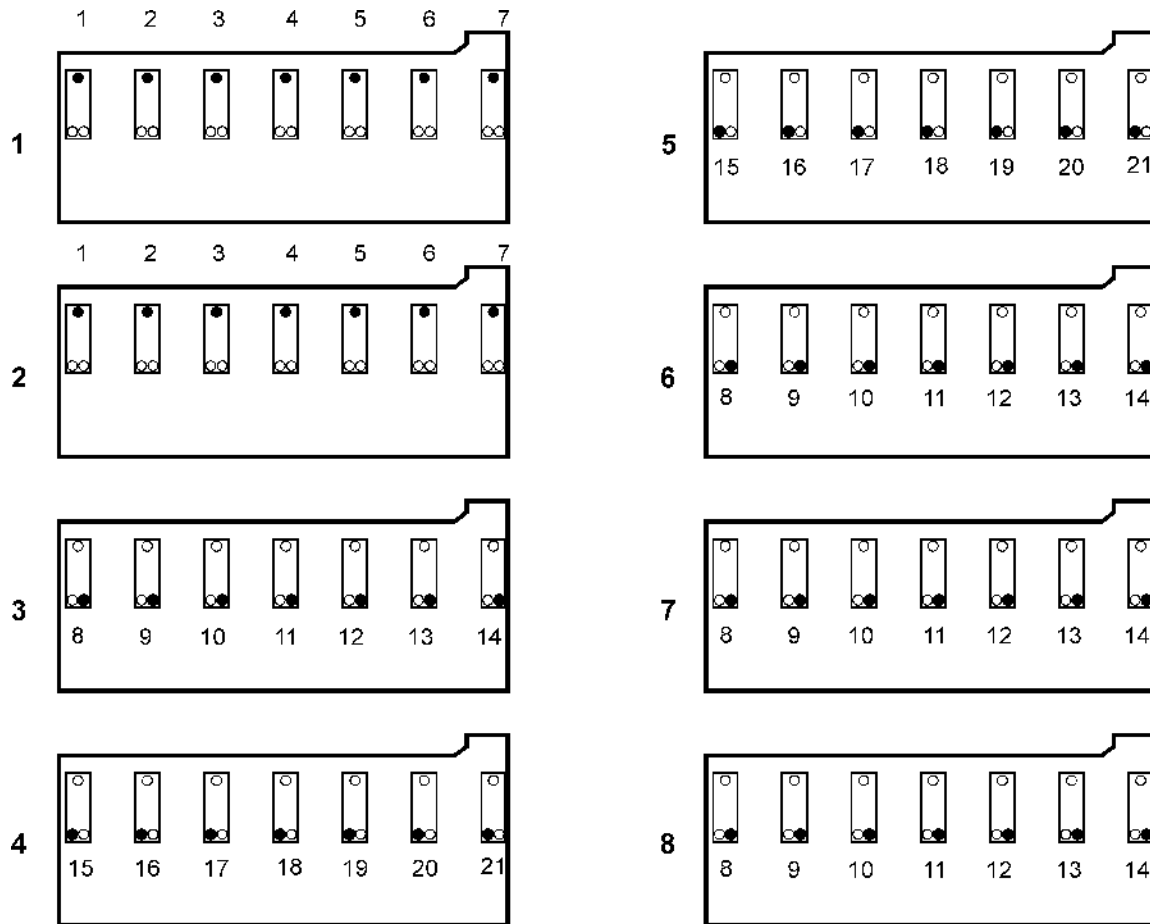

Bearing caps, camshaft/rocker arm shaft

Note! Tighten the screws in stages, to ensure that the rocker arm shaft comes down without being bent.

Stage 1: Tighten screws 1-7 15 ± 3 Nm (11 ± 2 lbf ft)

Stage 2: Torque screws 1-7 to 90° ±5° angle tightening

Stage 3: Tighten screws 8-14.
Start with screw 11 100 ± 10 Nm (74 ± 7 lbf ft)

Stage 4: Tighten screws 15-21 50 ± 5 Nm (37 ± 4 lbf ft)

Stage 5: Tighten screws 15-21 120° ±5° angle tightening

Stage 6: Loosen screws 8-14

Stage 7: Tighten screws 8-14 50 ± 5 Nm (37 ± 4 lbf ft)

Stage 8: Tighten screws 8-14 120° ±5° angle tightening

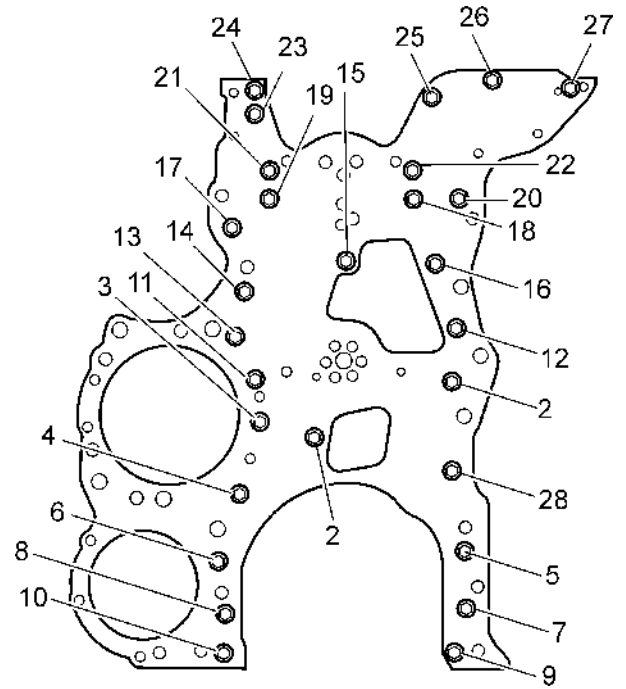
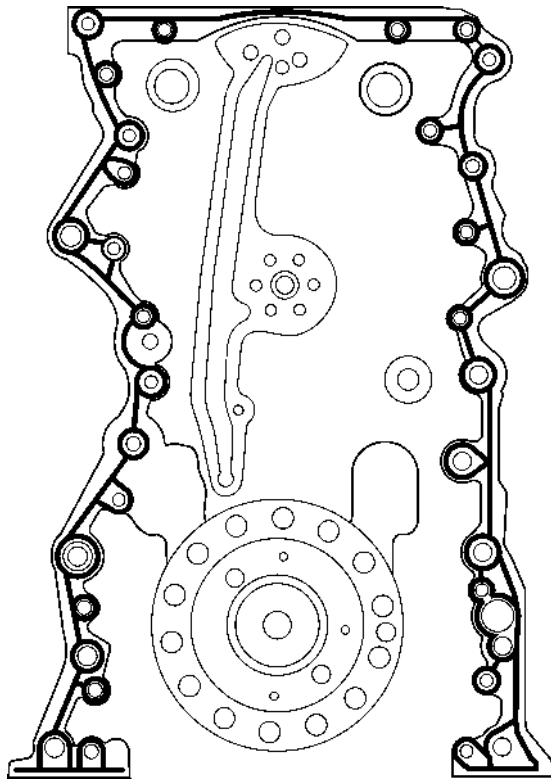

Timing gear plate

NOTE: Apply 2 mm (approx 1/8") silicon to the rear edge of the engine block as shown in the illustration.

NOTE: Tighten the screws in number order, as in the illustration.

| | |
|-------------------|---------------------------|
| Screws 1-27 | 28 ± 4 Nm (20 ± 3 lbf ft) |
| Screw 28 | 60 ± 8 Nm (44 ± 6 lbf ft) |

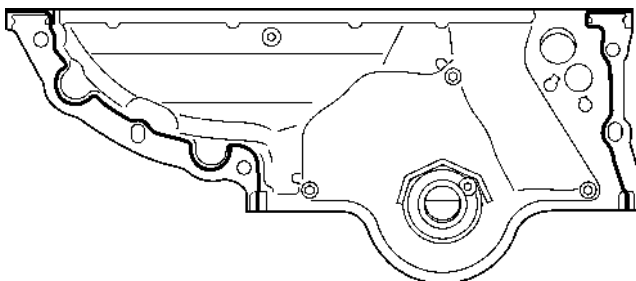

Timing gear cover, upper 24 ± 4 Nm (18 ± 3 lbf ft)

NOTE: Apply 2 mm (approx 1/8 inch) silicone sealer as in the illustration.

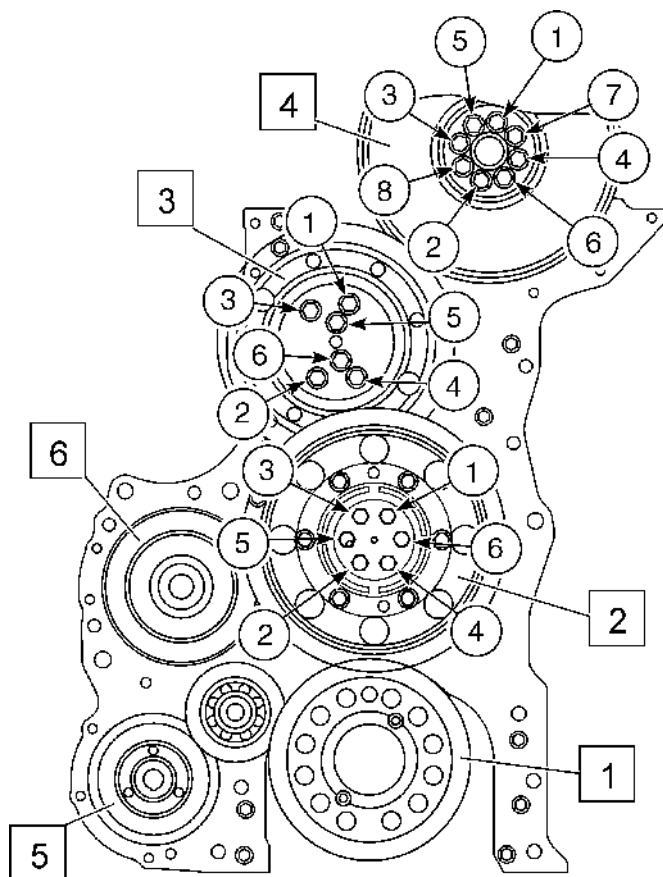

Timing gear

1 Driving gear, crankshaft

- stage 1 60 ± 5 Nm (44 ± 4 lbf ft)
- stage 2 120° ±10° angle tightening

2 Idler gear, bull gear, outer

Tighten in order according to illustration

- stage 1 45 ± 5 Nm (33 ± 4 lbf ft)
- stage 2 90° ±5° angle tightening

3 Idler gear, adjustable

Tighten screws in order according to illustration

- stage 1 35 ± 4 Nm (26 ± 3 lbf ft)
- stage 2 120° ±5° angle tightening

4 Drive gear, camshaft

Tighten screws in order according to illustration

- stage 1 45 ± 5 Nm (33 ± 4 lbf ft)
- stage 2 90° ± 5° angle tightening

5 Drive gear, steering servo and fuel feed pump . 100 ±10 Nm (74 ± 7 lbf ft)

6 Drive wheel, air compressor 200 ⁺⁵⁰₋₀ Nm (147.5 ^{+36.88}₋₀ lbf ft)

Tightening torque, group 22: Lubrication system

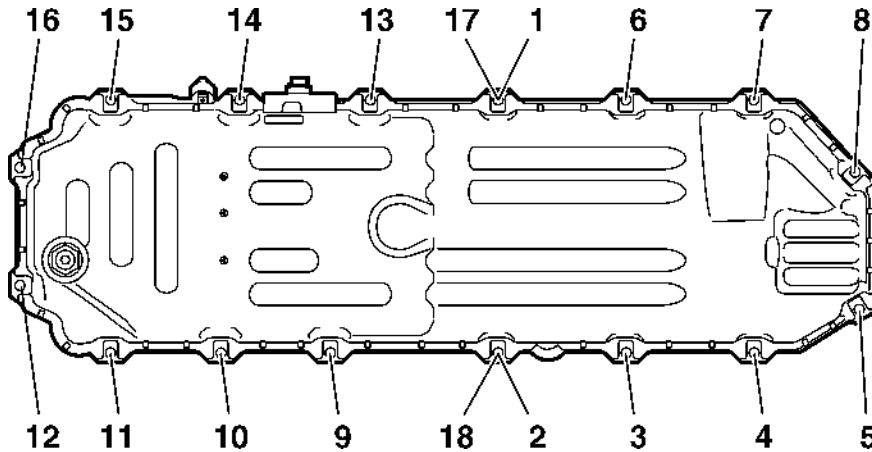

Oil pan 24 ±4 Nm (18 ± 3 lbf ft)

NOTE: Tighten the screws in number order, as in the illustration.

Oil pump

stage 1 35 ± 3 Nm (26 ± 2 lbf ft)

stage 2 90° ±5° angle tightening

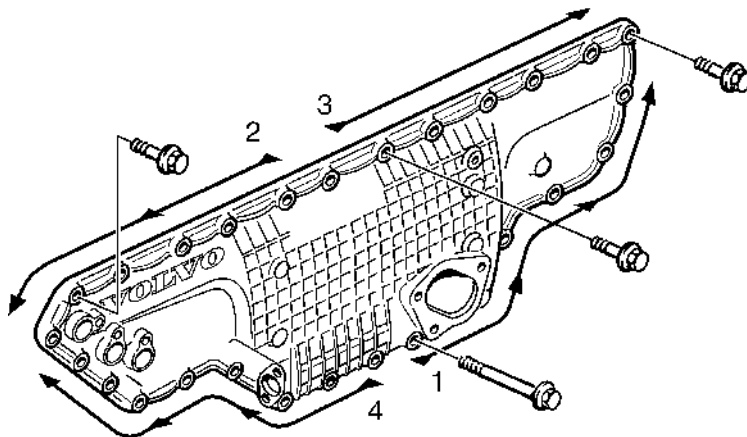

Oil cooler, fixing screws 27 ±4 Nm (20 ± 3 lbf ft)

Oil pressure pipe

stage 1 tighten to zero play

stage 2

pipe diameter Ø12 80 ± 10 Nm (59 ± 7 lbf ft)

pipe diameter Ø18 110 ± 10 Nm (81 ± 7 lbf ft)

pipe diameter Ø20 130 ±10 Nm (96 ± 7 lbf ft)

pipe diameter Ø22 170 ±10 Nm (125 ± 7 lbf ft)

pipe diameter Ø28 200 ± 10 Nm (148 ± 7 lbf ft)

Tightening torque, group 23: Fuel system

Feed pump - steering servo pump $25 \pm 2 \text{ Nm}$ ($18.5 \pm 1.5 \text{ lbf ft}$)

Fixing yoke, unit injector (new copper sleeve)

First tightening

Stage 1 $20 \pm 5 \text{ Nm}$ ($15 \pm 4 \text{ lbf ft}$)

Stage 2 $180^\circ \pm 5^\circ$ angle tightening

NOTE: Loosen the fastening yoke screw before performing the second tightening.

Second tightening

stage 1 $20 \pm 5 \text{ Nm}$ ($15 \pm 3.7 \text{ lbf ft}$)

stage 2 $60^\circ \pm 5^\circ$ angle tightening

Fixing yoke, unit injector (re-used copper sleeve)

stage 1 $20 \pm 5 \text{ Nm}$ ($15 \pm 3.7 \text{ lbf ft}$)

stage 2 $60^\circ \pm 5^\circ$ angle tightening

Lock nut for adjuster screw, unit injector

stage 1 tighten to contact

stage 2 $45^\circ \pm 5^\circ$ angle tightening

Lock nut, valve adjustment

stage 1 tighten to contact

stage 2 $60^\circ \pm 5^\circ$ angle tightening

Hollow screw M16x1.5 $50 \pm 8 \text{ Nm}$ ($37 \pm 6 \text{ lbf ft}$)

Hollow screw M10x1 $25 \pm 4 \text{ Nm}$ ($18.5 \pm 3 \text{ lbf ft}$)

Tightening torque, group 25: Inlet / exhaust system

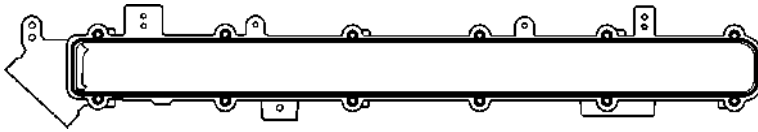

Inlet manifold 24 ± 4 Nm (18 ± 3 lbf ft)

NOTE: Apply a 2 mm (approx 1/8") bead of sealing compound 1161231-4, as shown in illustration.

Plug, M10 20 ± 3 Nm (15 ± 2 lbf ft)

Pressure/temperature sensor, charge air 12 ± 2 Nm (9 ± 1.5 lbf ft)

Exhaust header

Stage 1: Tighten screws "1" until they just touch (max 10 Nm (7.4 lbf-ft))

Stage 2: Tighten screws "2" until they just touch (max 10 Nm (7.4 lbf-ft))

Stage 3: Tighten screws "3" 52 ± 4 Nm (38 ± 3 lbf ft)

Stage 4: Tighten screws "2" 52 ± 4 Nm (38 ± 3 lbf ft)

Stage 5: Tighten screws "4" 52 ± 4 Nm (38 ± 3 lbf ft)

Stage 6: Tighten screws "1" 52 ± 4 Nm (38 ± 3 lbf ft)

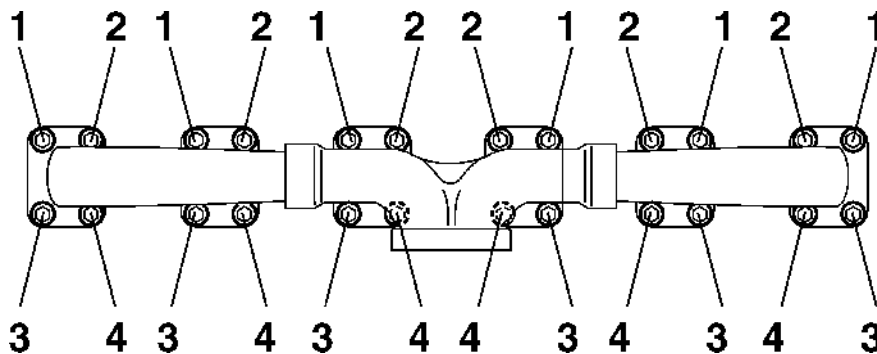

Report form

Do you have any complaints or other comments about this manual. Please make a copy of this page, write your comments down and send them to us. The address is at the bottom. We would prefer you to write in English or Swedish.

From:
.....
.....
.....

Refers to publication:

Publication No.: Date of issue:

Proposal/motivation:
.....
.....
.....
.....
.....
.....
.....
.....
.....

Date:

Signed:

AB Volvo Penta
Technical Information
Dept. 42200
SE-405 08 Göteborg
Sweden

Workshop Manual

Group 21-26

| |
|-------------|
| I |
| 4(0) |

**TAD1640GE, TAD1641GE, TAD1642GE
TAD1641VE, TAD1642VE**

Workshop Manual

Group 21-26

Industrial engine

TAD1640GE, TAD1641GE, TAD1642GE TAD1641VE, TAD1642VE

Contents

| | | | |
|--|-----------|--|-----------|
| Safety information | 3 | Boost pressure, troubleshooting | 39 |
| Introduction | 3 | Turbocharger, checking | 41 |
| General information | 6 | Exposing engine | 42 |
| About this Workshop Manual | 6 | Fixture fitting | 44 |
| Flat Rates | 6 | Engine body, general overhaul | 45 |
| Spare parts | 6 | Cylinder head, removal | 45 |
| Certified engines | 6 | Transmission, removal | 56 |
| Repair instructions | 7 | Pistons, removal | 58 |
| Our joint responsibility | 7 | Crankshaft, removal | 59 |
| Torque | 7 | Crankshaft, refitting | 60 |
| Torque-angle tightening | 8 | Cylinder liner, fitting | 61 |
| Lock nuts | 8 | Piston, pre-fitting | 62 |
| Strength classes | 8 | Pistons, fitting | 64 |
| Sealant | 8 | Piston cooling nozzle, fitting | 64 |
| Safety rules for fluorocarbon rubber | 9 | Transmission, fitting | 65 |
| Special tools | 10 | Cylinder head, refitting | 71 |
| Other special equipment | 14 | Camshaft, refitting | 74 |
| Design and function | 15 | Gear backlash, adjusting | 75 |
| Group 21: Engine body | 15 | Unit injector, refitting | 77 |
| Cylinder head | 15 | Adjustment markings | 79 |
| Engine block | 16 | Valves and injectors, adjusting | 79 |
| Cylinder liner | 17 | Reconditioning / replacing components | 83 |
| Pistons and connecting rods | 18 | Group 21: Engine body | 83 |
| Crankshaft | 19 | Cylinder liner and pistons, inspection | 83 |
| Camshaft | 20 | Cylinder liner and pistons, replacing (all) | 84 |
| Transmission | 21 | Crankshaft, inspection | 90 |
| Group 22 Lubrication system | 22 | Main bearings, replacing | 91 |
| Piston cooling | 23 | Crank bearing, replacing (all) | 94 |
| Overview, valves | 24 | Flywheel bearing, replacing | 95 |
| Group 23 Fuel system | 25 | Flywheel, replacing | 96 |
| Unit injector, work phases | 27 | Ring gear, replacing | 97 |
| Group 25 Intake and exhaust system | 29 | Flywheel sensor distance, checking | 98 |
| Turbocharger | 29 | Flywheel, checking for warp | 99 |
| Group 26 Cooling system | 30 | Crankshaft seal, front, replacing | 100 |
| Troubleshooting / Tests and adjustments | 31 | Crankshaft seal, rear, replacing | 102 |
| Symptoms and possible causes | 31 | Connecting rod, checking | 104 |
| Operational disturbances | 32 | Connecting rod bushing, check measurement | 104 |
| Clogging | 32 | Valves, removal | 105 |
| Placement of instrument socket | 33 | Valves, fitting | 107 |
| Sensor overview | 34 | Valve seat, replacing | 108 |
| Compression test | 35 | Valve guides, inspection | 110 |
| Cooling system, pressure-testing | 38 | Valve guides, replacing | 111 |
| | | Valve seat, grinding | 112 |

| | |
|---|------------|
| Valves, grinding | 113 |
| Valve stem seals, replacing | 114 |
| Cylinder head, pressure testing | 116 |
| Copper sleeve for unit injector, replacing | 119 |
| Camshaft, checking for wear | 123 |
| Camshaft bearing housing, replacing | 124 |
| Camshaft sensor distance, checking | 125 |
| Transmission, replacing | 126 |
| Group 22: Lubrication system | 132 |
| When working with chemicals, fuel and lubricating oil ... | 132 |
| Overview, control valves | 132 |
| Pressure reduction valve, replacing | 133 |
| Bypass valve, oil filter, replacing | 133 |
| Oil pressure safety valve, replacing | 134 |
| Piston cooling valves, replacing | 134 |
| Bypass valve oil filters, full flow, replacing | 135 |
| Oil filters, checking | 136 |
| Oil pressure sensor, checking | 136 |
| Engine oil and oil filters, replacing | 137 |
| Pressure reduction valve, checking | 138 |
| Safety valve, checking | 138 |
| Oil pump, replacing | 139 |
| Oil pump, checking | 140 |
| Oil cooler | 141 |
| Oil cooler, leakage test | 142 |
| Bypass valve oil cooler, replacing | 143 |
| Group 23: Fuel system | 144 |
| Draining, fuel channel in cylinder head | 144 |
| Control module, replacing | 145 |
| Fuel filters, replacing | 147 |
| Primary fuel filter, change | 148 |
| Fuel feed pump, replacing | 149 |
| Unit injector, replacing | 150 |
| Venting the fuel system | 153 |
| Group 25: Inlet / exhaust systems | 154 |
| Turbo, replacing | 154 |
| Group 26: Cooling system | 156 |
| Cooling system, draining | 156 |
| Cooling system, cleaning | 157 |
| Cooling system, pressure-testing | 158 |
| Cooling system, filling | 159 |
| Coolant pump, replacing | 160 |
| Thermostat, functional check | 161 |
| Thermostat, replacing | 161 |
| Coolant filter, changing | 162 |
| Alternator belt/ Drive belt, checking | 163 |
| Drive belt, changing | 163 |
| Alternator belts, changing | 164 |

Safety information

Introduction

This Workshop Manual contains descriptions and instructions for the repair of the Volvo Penta products or product versions. Check that you have the correct Workshop Manual for your engine.

Before starting work on the engine, read these safety precautions with care as well as “General information” and “Service procedures.”

Important

In this book and on the product you will find the following special warning symbols.

 **WARNING!** Possible danger of personal injury, extensive damage to property or serious mechanical malfunction if the instructions are not followed.

 **IMPORTANT!** Used to draw your attention to something that can cause damage or malfunctions on a product or damage to property.

NOTE: Used to draw your attention to important information that will facilitate the work or operation in progress.

Below is a summary of the risks involved and safety precautions you should always observe or carry out when operating or servicing the engine.

 Immobilize the engine by turning off the power supply to the engine at the main switch (switches) and lock it (them) turned off before starting work. Set up a warning notice at the engine control point.

 As a general rule all service operations must be carried out with the engine stopped. However, some work, for example certain adjustments require that the engine is running when they are carried out. Approaching an engine which is operating is a safety hazard. Remember that loose clothing or long hair can fasten in rotating parts and cause serious personal injury.

 If work is done adjacent to a running engine, a careless movement or a dropped tool can lead to personal injury in the worst case. Take care to avoid contact with hot surfaces (exhaust pipes, Turbocharger (TC), air intake pipe, starter heater etc.) and hot liquids in lines and hoses on an engine which is running or which has just been stopped. Reinstall all protective parts removed during service operations before starting the engine.

 Check that the warning or information labels on the product are always clearly visible. Replace labels which have been damaged or painted over.

 Never start the engine without installing the air cleaner filter. The rotating compressor turbine in the turbocharger can cause severe injury. Foreign objects entering the intake ducts can also cause mechanical damage.













 Never use start spray or similar products as a starting aid. They may cause an explosion in the inlet manifold. Danger of personal injury.

 Only start the engine in a well-ventilated area. If operating the engine in an enclosed area ensure that there is exhaust ventilation leading out of the engine compartment or workshop area.

 Avoid opening the coolant filler cap when the engine is hot. Steam or hot coolant can spray out and the system pressure will be lost. When needed, open the filler cap slowly and release the pressure in the system. Be very careful if a cock or plug or engine coolant line must be removed when the engine is hot. It is difficult to anticipate in which direction steam or hot coolant can spray out.

 Hot oil can cause burns. Avoid getting hot oil on the skin. Ensure that the lubrication system is not under pressure before carrying out any work. Never start or operate the engine with the oil filler cap removed, otherwise oil could be ejected.

 Stop the engine before carrying out operations on the engine cooling system.

-  Always use protective glasses or goggles when carrying out work where there is a risk of splinters, grinding sparks, acid splashes or where other chemicals are used. The eyes are extremely sensitive. An injury could result in blindness!
-  Avoid getting oil on the skin! Repeated exposure to oil or exposure over a long period can result in the skin becoming dry. Irritation, dryness and eczema and other skin problems can then occur. Used oil is more dangerous than fresh oil from a health aspect. Use protective gloves and avoid oil soaked clothes and shop rags. Wash regularly, especially before eating. There are special skin creams which counteract drying out of the skin and make it easier to clean off dirt after work is completed.
-  Many chemicals used on the product (such as engine and transmission oils, glycol, gasoline and diesel oil), or chemicals used in the workshop (such as degreasers, paint and solvents) are hazardous to health. Read the instructions on the product packaging with care! Always follow the safety precautions for the product (for example use of protective mask, glasses, gloves etc.). Make sure that other personnel are not unknowingly exposed to hazardous chemicals, for example in the air. Ensure good ventilation in the work place. Follow the instructions provided when disposing of used or leftover chemicals.
-  Exercise extreme care when leak detecting on the fuel system and testing the fuel injector nozzles. Use eye protection. The jet from a fuel injector nozzle is under extremely high pressure and has great penetrative energy, so the fuel can penetrate deep into the body tissue and cause serious personal injury. Danger of blood poisoning (septicemia).
-  **WARNING!** The delivery pipes must under no circumstances be bent. Damaged pipes should be replaced.
-  All fuels and many chemical substances are flammable. Do not allow naked flame or sparks in the vicinity. Certain thinner products and hydrogen from batteries can be extremely flammable and explosive when mixed with air in the right proportions. No Smoking! Ensure that the work area is well ventilated and take the necessary safety precautions before starting welding or grinding work. Always ensure that there are fire extinguishers at hand when work is being carried out.
-  Ensure that rags soaked in oil or fuel and used fuel or oil filters are stored safely. Rags soaked in oil can spontaneously ignite under certain circumstances. Used fuel and oil filters are environmentally dangerous waste and must be deposited at an approved site for destruction together with used oil, contaminated fuel, left over paint, solvents, degreasers and waste from washing parts.
-  Never expose a battery to naked flame or electrical sparks. Never smoke close to the batteries. The batteries give off hydrogen gas during charging which when mixed with air can form an explosive gas - oxyhydrogen. This gas is easily ignited and highly explosive. A spark, which can be caused by incorrect battery connection, can cause a single spark which is sufficient to cause an explosion with resulting damage. Do not shift the connections when attempting to start the engine (spark risk) and do not lean over any of the batteries.
-  Always ensure that the Plus (positive) and Minus (negative) battery cables are correctly installed on the corresponding terminal posts on the batteries. Incorrect installation can result in serious damage to the electrical equipment. Refer to the wiring diagram.
-  Always use protective goggles when charging and handling the batteries. Battery electrolyte contains sulfuric acid which is highly corrosive. Should the battery electrolyte come into contact with unprotected skin wash off immediately using plenty of water and soap. If battery acid comes in contact with the eyes, immediately flush with plenty of water and obtain medical assistance at once.
-  Turn the engine off and turn off the power at the main switch(es) before carrying out work on the electrical system.
-  Clutch adjustments must be carried out with the engine stopped.

 Use the lifting eyes fitted on the engine when lifting the drive unit. Always check that the lifting equipment used is in good condition and has the load capacity to lift the engine (engine weight including gearbox, if fitted, and any extra equipment installed). Use an adjustable lifting beam or lifting beam specifically for the engine to raise the engine to ensure safe handling and to avoid damaging engine parts installed on the top of the engine. All chains and cables should run parallel to each other and as perpendicular as possible in relation to the top of the engine. If extra equipment is installed on the engine which alters its center of gravity a special lifting device is required to obtain the correct balance for safe handling.

Never carry out work on an engine suspended on a hoist.

 Never work alone when removing heavy engine components, even when using lifting devices such as locking tackle lifts. When using a lifting device two people are usually required to do the work, one to take care of the lifting device and another to ensure that components are lifted clear and not damaged during the lifting operations.

Always check before starting work if there is enough room to carry out removal work without risking personal injury or damage to the engine or parts.

 **WARNING!** The components in the electrical system and in the fuel system on Volvo Penta products are designed and manufactured to minimize the risk of fire and explosion. The engine must not be run in areas where there are explosive materials.

 Always use fuels recommended by Volvo Penta. Refer to the Instruction Book. Use of fuels that are of a lower quality can damage the engine. On a diesel engine poor quality fuel can cause the control rod to seize and the engine to overrev with resulting risk of damage to the engine and personal injury. Poor fuel quality can also lead to higher maintenance costs.

 Remember the following when washing with a high pressure washer: Never direct the water jet at seals, rubber hoses, electrical components or the radiator. Never use the high pressure feature when cleaning an engine.

General information

About this Workshop Manual

The workshop manual contains a description of the engine and instructions for the repair of standard versions of engine TAD1640GE, TAD1641GE, TAD1642GE, TAD1641VE and TAD1642VE.

The workshop manual, Technical data, contains specifications and torque for standard versions of engine TAD1640GE, TAD1641GE, TAD1642GE, TAD1641VE and TAD1642VE. In this book you will find all references from the workshop manual.

The Engine Designation and Engine Numbers can be found on the product plate.

Please always include both the engine designation and the engine number in all correspondence.

The Workshop Manual is produced primarily for the use of Volvo Penta workshops and service technicians. For this reason the manual presupposes a certain basic knowledge and that the user can carry out the mechanical/electrical work described to a general standard of engineering competence.

AB Volvo Penta products are under a continual process of development and we therefore reserve all rights regarding changes and modifications. All the information in this manual is based on product specifications available at the time the book was published. Any essential changes or modifications of the product or revised service methods introduced after the date of publication will be provided in the form of Service Bulletins.

Flat Rates

Operation numbers that show in instruction headings refer to Volvo Penta Flat Rates.

Spare parts

Spare parts for the electrical and fuel systems are subject to various national safety requirements. Volvo Penta Original Spare Parts meet these specifications. Any type of damage which is the result of using spare parts that are not original Volvo Penta parts for the product in question will not be covered under any warranty or guarantee provided by AB Volvo Penta.

Certified engines

Manufacturer warrants that both new and currently operating engines that are certified to national and regional environmental regulations meet environmental requirements. The product must correspond to the engine that was approved during certification. In order that Volvo Penta, as manufacturer, will be able to warrant that engines in operation meet environmental requirements, the following requirements for service and spare parts must be met:

- Service and maintenance intervals recommended by Volvo Penta must be followed.
- Only Volvo Penta Original Spare Parts intended for the certified engine version may be used.
- Service work that covers injection pumps, pump settings, and injectors must always be carried out by an authorized Volvo Penta workshop.
- The engine must not be altered or modified in any way, except for accessories and service kits developed by Volvo Penta for that engine.
- No modifications to the exhaust pipes and engine room air intake pipes are allowed.
- Any seals on the engine may not be broken by unauthorized persons.

 **IMPORTANT!** When spare parts are required, use only Volvo Penta original parts.

Use of non-original parts will result in AB Volvo Penta being unable to warrant that the engine corresponds to the certificated engine version.

Any type of damages or costs which are the result of using spare parts that are not original Volvo Penta parts for the product in question will not be paid for by AB Volvo Penta.

Repair instructions

The working methods described in the Workshop Manual apply to work carried out in a workshop. The engine has been removed and is installed in an engine fixture. Unless otherwise stated reconditioning work which can be carried out with the engine in place follows the same working method.

Warning symbols used in this Workshop Manual (for full explanation of the symbols refer to the section; “Safety Precautions”)

 **WARNING!**

 **IMPORTANT!**

NOTE:

are not in any way comprehensive since it is impossible to predict every circumstance under which service work or repairs may be carried out. AB Volvo Penta can only indicate the risks considered likely to occur as a result of incorrect working methods in a well equipped workshop using working methods and tools tested by AB Volvo Penta.

All operations described in the Workshop Manual for which there are Volvo Penta Special Tools available assume that these tools are used when carrying out the repair. Volvo Penta Special Tools have been specifically developed to ensure as safe and rational working methods as possible. It is therefore the responsibility of anyone using other tools or other working methods than we recommend to determine that there is no risk of personal injury or mechanical damage or malfunction as a result.

In some cases special safety precautions and user instructions may be required in order to use the tools and chemicals mentioned in the Workshop Manual. These rules must always be observed, so there are no special instructions about this in the workshop manual.

By following these basic recommendations and using common sense it is possible to avoid most of the risks involved in the work. A clean work place and a clean engine will eliminate many risks of personal injury and engine malfunction.

Especially when working on the fuel system, engine lubrication system, air intake system, turbocharger unit, bearing seals and seals, it is extremely important to avoid dirt or foreign objects entering the parts or systems, since this can result in reduced service life or malfunctions.

Our joint responsibility

Each engine consists of a large number of collaborating systems and components. Any deviation of a component from its technical specification can dramatically increase the environmental impact of an otherwise good engine. It is therefore critical that the stated wear tolerances are observed, that systems which can be adjusted are correctly set up and that only Volvo Penta Original Parts are used on the engine. The stated service intervals in the Maintenance Schedule must be observed.

Some systems, such as the components in the fuel system, require special expertise and special testing equipment for service and maintenance. Some components are sealed at the factory, for environmental reasons etc. Under no circumstances attempt to service or repair a sealed component unless the service technician carrying out the work is authorized to do so.

Bear in mind that most chemical products, incorrectly used, are hazardous to the environment. Volvo Penta recommends the use of bio-degradable degreasing agents for all cleaning of engine components unless otherwise stated in the Workshop Manual. Pay special attention to make sure that oils and washing residue etc are handled correctly for destruction, and do not unintentionally end up in nature.

Torque

Correct torque for critical joints which must be tightened using a torque wrench are listed under “Technical Data”: Torque” and stated in the method descriptions in the Workshop Manual. All torque data apply to cleaned threads, bolt heads and mating surfaces. Torque data stated apply to lightly oiled or dry threads. Where grease, locking or sealing agents are required for screwed joints this is stated in both the operation description and in “torque.” Where no torque is stated for a joint use the general torque shown in the following table. The torques stated are a guide and the joint does not have to be tightened using a torque wrench.

| Dimension | Torque Nm |
|-----------|--------------|
| M5 | 6 |
| M6 | 10 |
| M8 | 25 |
| M10 | 50 |
| M12 | 80 |
| M14 | 140 |
| M16 | 220 |

Torque-angle tightening

When torquing with protractor (angle tightening), the fastener is tightened to a predetermined torque and then turned a predetermined angle. Example: a 90° protractor tightening means that the joint is tightened a further 1/4 turn in one operation after the stated torque has been applied.

Lock nuts

Do not re-use lock nuts that have been removed during disassembly operations as these have reduced service life when re-used. For lock nuts with a plastic insert such as Nylock® the torque stated in the table is reduced if the Nylock® nut has the same head height as a standard hexagonal nut without plastic insert. Reduce the torque by 25% for screw size 8 mm or larger. Where Nylock® nuts are higher, where the metallic thread is of the same height as a standard hexagonal nut, the torques given in the as shown in table apply.

Strength classes

Screws and nuts are sub-divided into different strength classes. Classification is indicated by markings on the screw head. A higher number indicates a material with greater strength. For example, a screw marked 10-9 is stronger than one marked 8-8. For this reason, it is important when fasteners are dismantled, that the screws are put back in the correct places when they are re-installed. If a bolt must be replaced, check in the spare parts catalogue to make sure the correct bolt is used.

Sealant

A number of sealants and locking liquids are used on the engines. The properties of the preparations differ, and they are intended for different strengths of fastener, temperature, resistance to oil and other chemicals, and for the different materials and gap thicknesses found in the engine.

To ensure service work is correctly carried out it is important that the correct sealant and locking fluid type is used on the joint where the agents are required.

In this Volvo Penta Workshop Manual the user will find that each section where these agents are applied in production states which type was used on the engine.

During service operations, use the same agent or an alternative from a different manufacturer.

Make sure that mating surfaces are dry and free from oil, grease, paint and anti-corrosion agent before applying sealant or locking fluid.

Always follow the manufacturer's instructions for use regarding temperature range, curing time and any other instructions for the product.

Two different basic types of agent are used on the engine. These are:

RTV agent (Room temperature vulcanizing). Used for gaskets, sealing gasket joints or coating gaskets. RTV is visible when a part has been disassembled; old RTV must be removed before resealing the joint.

The following RTV agents are mentioned in the Workshop Manual: Loctite® 574, Permatex® No. 3, Permatex® No 77. Old sealant can be removed using denatured alcohol in all cases.

Anaerobic agents. These agents cure in an absence of air. They are used when two solid parts, for example cast components, are installed face-to-face without a gasket. They are also commonly used to secure plugs, threads in stud bolts, cocks, oil pressure switches etc. Hardened anaerobic preparations are glassy and for this reason, the preparations are colored to make them visible. Cured anaerobic agents are extremely resistant to solvents and the old agent cannot be removed. When reinstalling the part, degrease it carefully and then apply new sealant.

The following anaerobic agents are mentioned in the Workshop Manual: Loctite® 572 (white), Loctite® 241 (blue).

NOTE: Loctite® is a registered trademark of Loctite Corporation, Permatex® is a registered trademark of the Permatex Corporation.

Safety rules for fluorocarbon rubber

Fluorocarbon rubber is a common material in seal rings for shafts, and in O-rings, for example.

When fluorocarbon rubber is subjected to high temperatures (above 300°C/572°F), **hydrofluoric acid** can be formed, which is highly corrosive. Contact with the skin can result in severe chemical burns. Splashes in your eyes can result in severe chemical burns. If you breathe in the fumes, your lungs can be permanently damaged.



WARNING! Be very careful when working on engines which have been exposed to high temperatures, e.g. overheating during a seizure or fire. Seals must never be cut with a flame torch during disassembly, or burned in uncontrolled circumstances afterwards.

- Always use gloves made of chloroprene rubber (gloves for handling chemicals) and protective goggles.
- Handle the removed seal in the same way as corrosive acid. All residue, including ash, can be highly corrosive. Never use compressed air to blow anything clean.
- Put the rest in a plastic jar which is sealed and provided with a warning label. Wash the gloves under running water before removing them.

The following seals are probably made from fluorocarbon rubber:

Seal rings for the crankshaft, camshaft, intermediate shafts.

O-rings, regardless of where they are installed. O-rings for cylinder liner sealing are almost always made of fluorocarbon rubber.

Note that seals which have not been subjected to high temperature can be handled normally.

Special tools

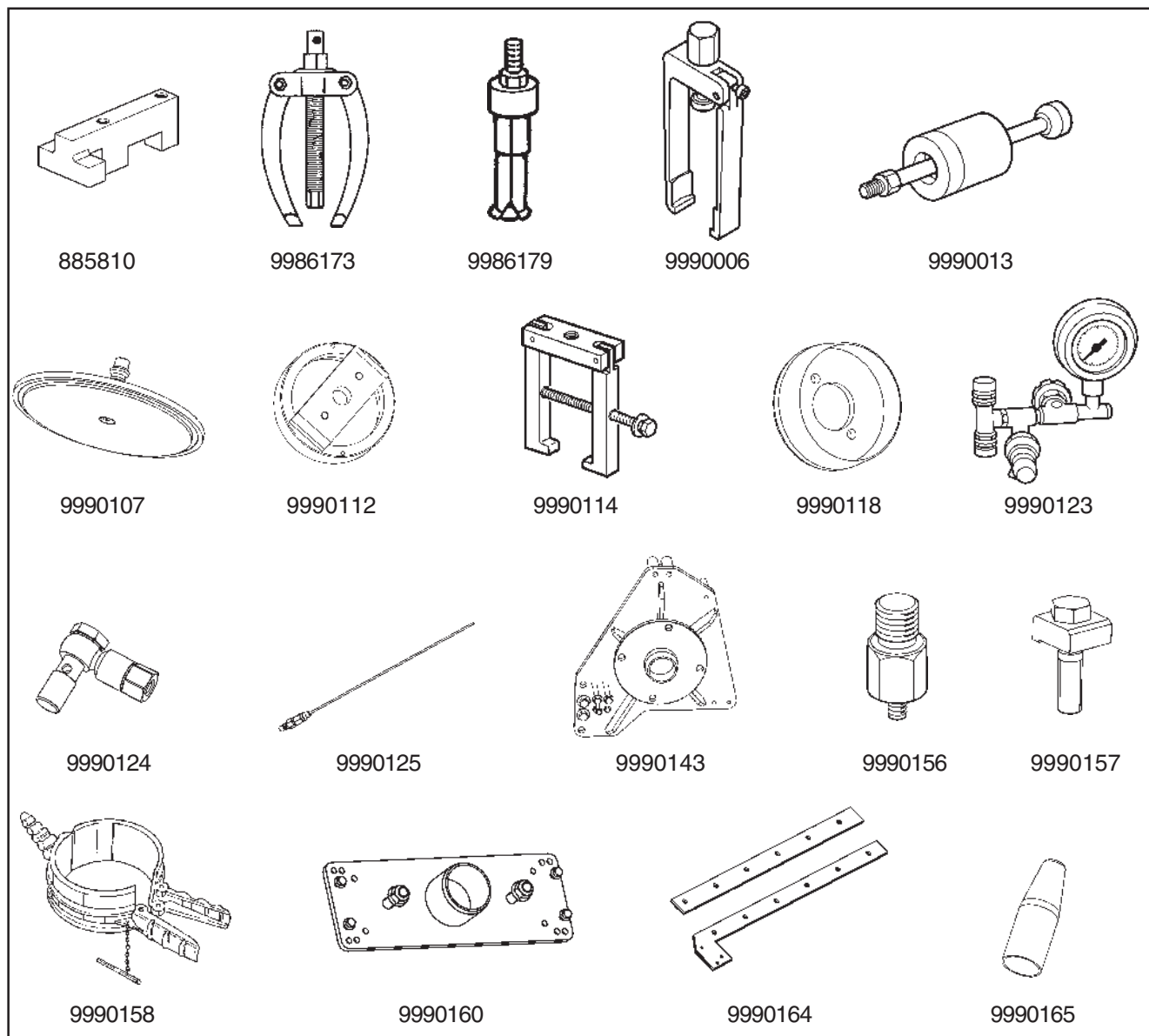

| | | | |
|----------------|--|----------------|---|
| 885810 | Fixture for upper transmission gear casing | 9990125 | Nipple for checking of boost pressure gauge, with 4 mm (0.16") hose |
| 9986173 | Puller, flywheel bearing | 9990143 | Engine fixture |
| 9986179 | Puller, flywheel bearing | 9990156 | Sealing plug adapter 9998251 |
| 9990006 | Puller, unit injector | 9990157 | Cylinder liner press tool (7 ea are required) |
| 9990013 | Slide hammer | 9990158 | Piston ring compressor |
| 9990107 | Connection washer for thermostat housing at cylinder head pressure testing | 9990160 | Fixture, cylinder head |
| 9990112 | Drift, removal of front crankshaft seal | 9990164 | Sealing washer for cylinder head pressure testing |
| 9990114 | Puller for main bearing caps | 9990165 | Guide sleeve for valve stem seal |
| 9990118 | Cone, refitting front crankshaft seal | | |
| 9990123 | Pressure testing device | | |
| 9990124 | Nipple for checking of the fuel delivery pipes | | |



| | | | |
|----------------|--|----------------|---|
| 9990166 | Tools for rear crankshaft seal | 9992000 | Standard handle |
| 9990174 | Drift, removal/refitting valve springs, outlet | 9992269 | Drift, installation of flywheel bearing |
| 9990176 | Press tool for removal/refitting of valve springs and valve guides | 9992479 | Holder for dial indicator |
| 9990183 | Drift for replacement of valve controls, re-fitting | 9992670 | Manual pump, used with 9996161, alt. for 9996222 |
| 9990184 | Drift for replacement of valve controls, removal | 9992873 | Connecting nipple for pressure checking |
| 9990185 | Lifting tool for rocker bridge | 9993590 | Turning tool |
| 9990192 | Puller for rear crankshaft seal, used together with 9996400 | 9996049 | Coolant drain tube |
| 9990210 | Valve spring compressor | 9996159 | Adapter for hydraulic cylinder 9996161 |
| 9991801 | Handle, replacing flywheel bearing | 9996161 | Hydraulic cylinder, used with press tool 9990176 |
| | | 9996222 | Pneumatic hydraulic pump, used with 9996161, alt. for 9992670 |

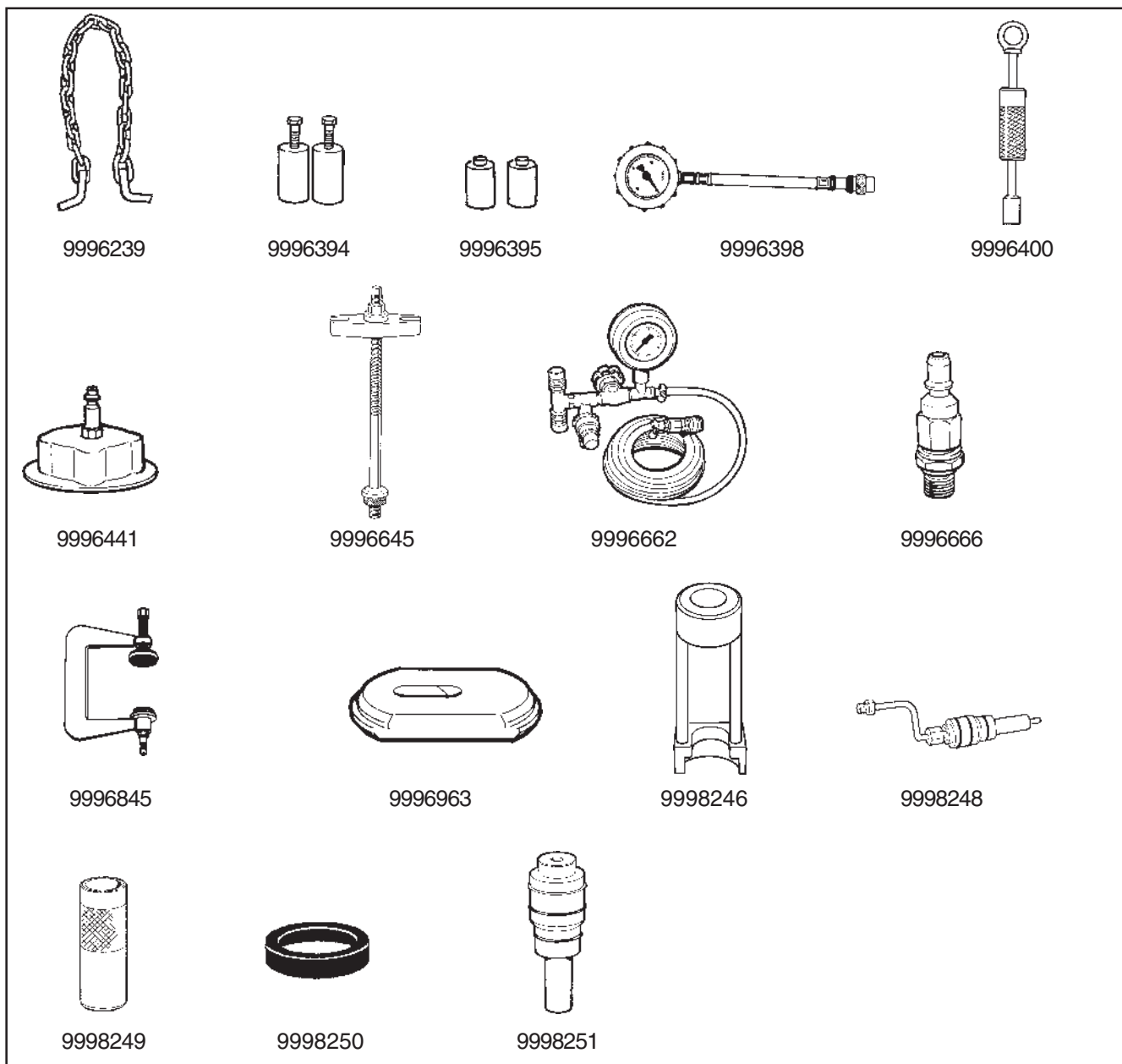

9996239 Lifting chain, removal/refitting of cylinder head and flywheel casing, (2 ea required)

9996394 Spacer for removal of cylinder liner, 2 ea are used with 9996645

9996395 Spacer for removal of cylinder liner, 2 ea are used with 9996645

9996398 Pressure gauge with quick-connect, 1.5 MPa

9996400 Slide hammer for removal of protection plug 9998251 for cylinder head. Also for removal of rear crankshaft seal together with 9990192.

9996441 Cover with connecting nipple for cooling system leakage test

9996645 Cylinder liner puller

9996662 Pressure testing device

9996666 Connecting nipple for pressure checking

9996845 Screw clamp for oil cooler pressure testing, (2 ea required)

9996963 Plate for cylinder liner removal/refitting

9998246 Drift, removal/refitting of valve springs, inlet

9998248 Adapter for measuring compression pressure (6 ea required)

9998249 Protective sleeve for unit injector (6 ea required)

9998250 Sealing ring for fuel channel in the cylinder head when replacing copper sleeve (2 ea required)

9998251 Protection plugs for cylinder head (6 ea required)

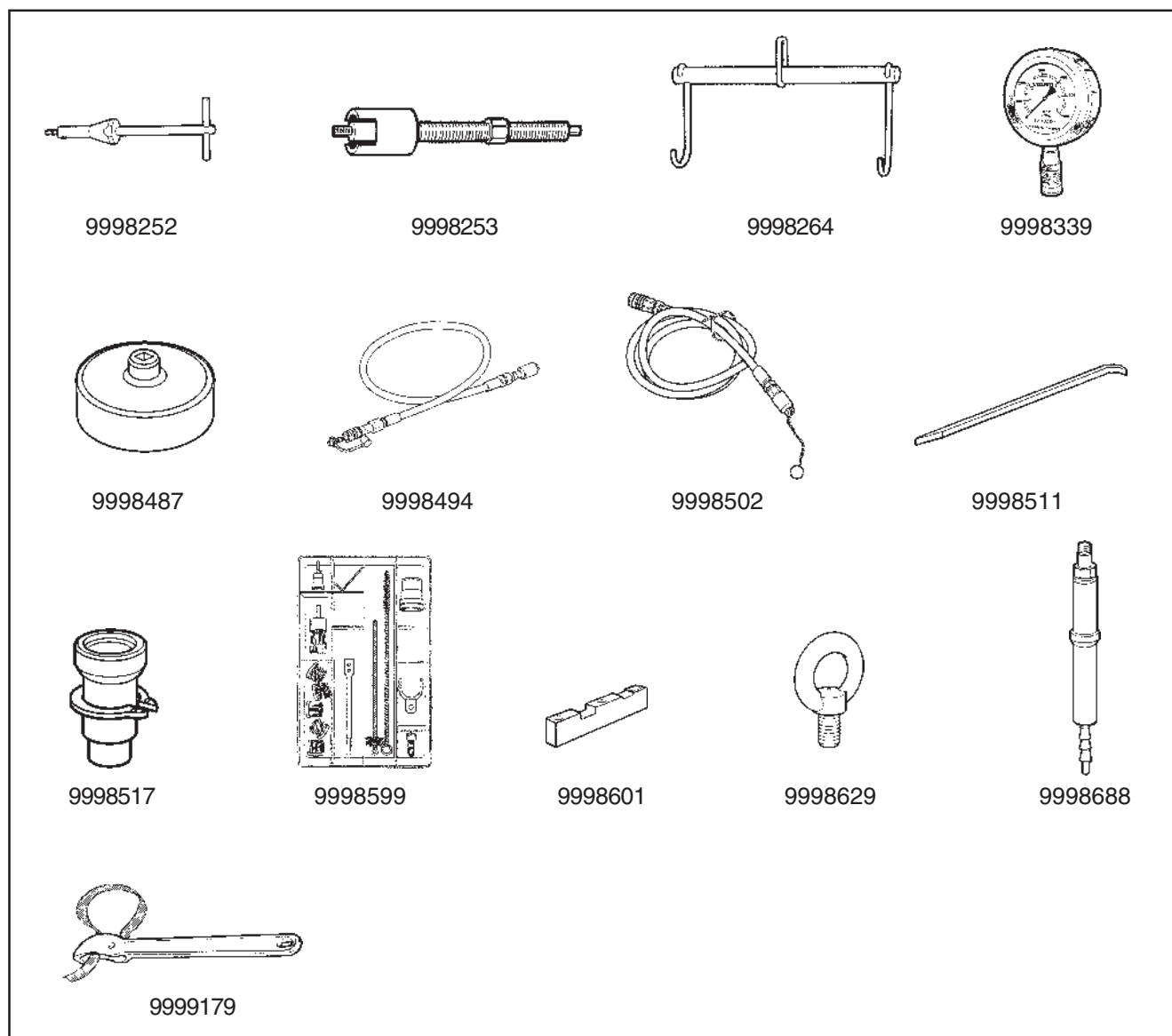

- 9998252** Thread cutting tool for removal of copper sleeve. Consists of: **9809667** (M9) and **9987009** (M8). For D16, only **9809667** is used for removal of unit injector copper sleeve
- 9998253** Copper sleeve puller. Consists of: **9809746** (M8) and **9809668**. For D16, only **9809668** is used.
- 9998264** Lifting yoke for camshaft
- 9998339** Pressure gauge, 6 bar
- 9998487** Socket for removal of oil filters
- 9998494** Hose with nipple for measuring fuel pressure (red), used with 9990123 and 9990124
- 9998502** Hose (green) for cooling system pressure testing, used with 9990123
- 9998511** Crowbar
- 9998517** Tool for checking/adjustment of flywheel and camshaft wheel sensor
- 9998599** Unit injector cleaning kit. Consists of:
- 959239 Screw M10
 - 9808570 Brush
 - 9808607 Holder
 - 9808613 Holder
 - 9808614 Brush
 - 9808615 Holder
 - 9808616 Handle
 - 9808617 Brush
 - 9808618 Brush
 - 9808634 Brush kit
 - 9998580 Socket
- 9998601** Fixture for upper gear case
- 9998629** Lifting eye M10, 2 ea required
- 9998688** Expander, replacing copper sleeve
- 9999179** Filter puller, universal

Other special equipment

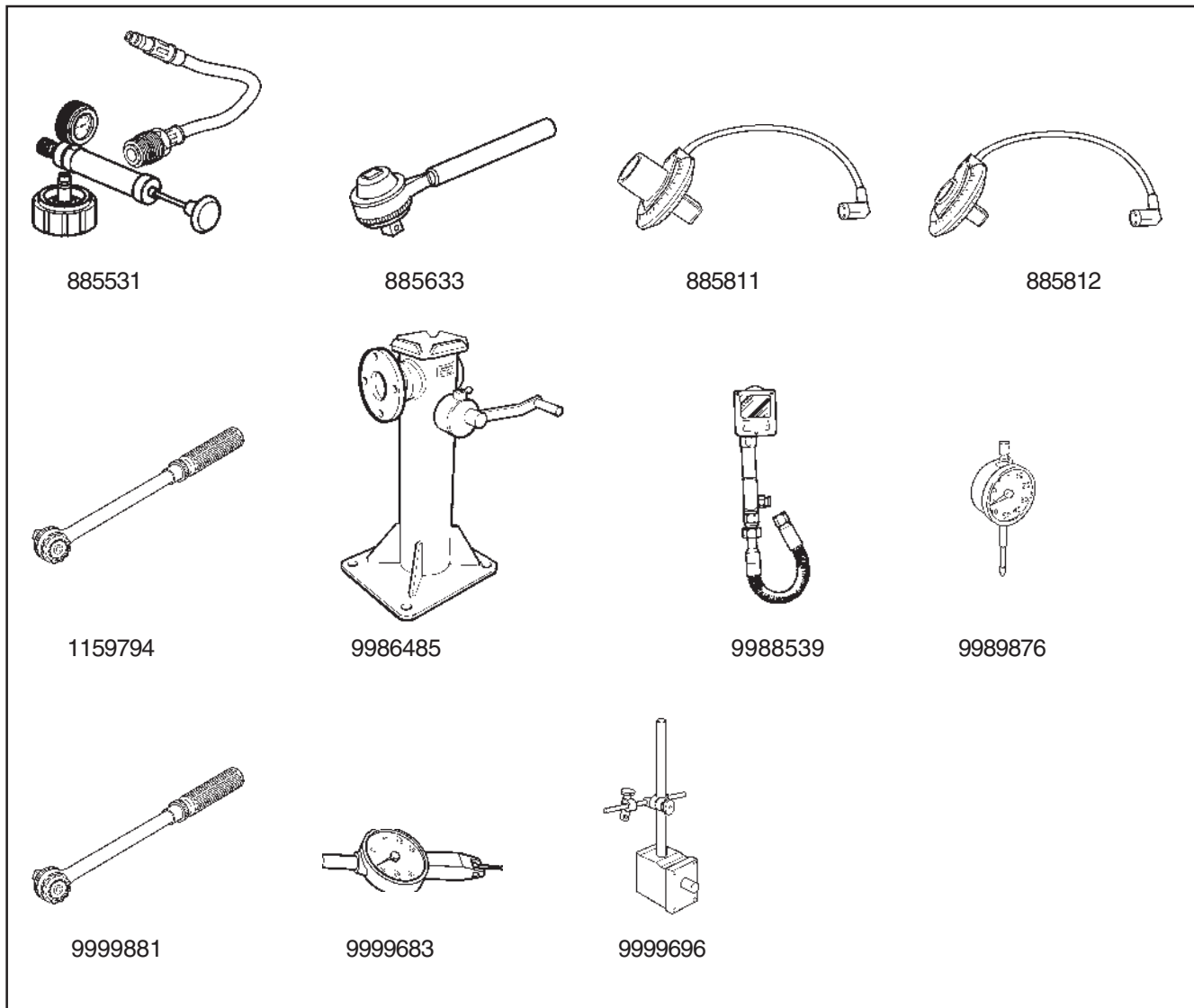

- 885531** Pressure-testing equipment, cooling system
- 885633** Torque amplifier 1/2" - 3/4"
- 885811** Angle gauge 3/4"
- 885812** Angle gauge 1/2"
- 1159794** Torque wrench 3/8, 10 - 100 Nm
(7.4 - 74 lbf ft)
- 9986485** Assembly stand
- 9988539** Compression gauge
- 9989876** Dial indicator
- 9999881** Torque wrench
- 9999683** Dial indicator
- 9999696** Magnetic stand

Design and function

Group 21: Engine body

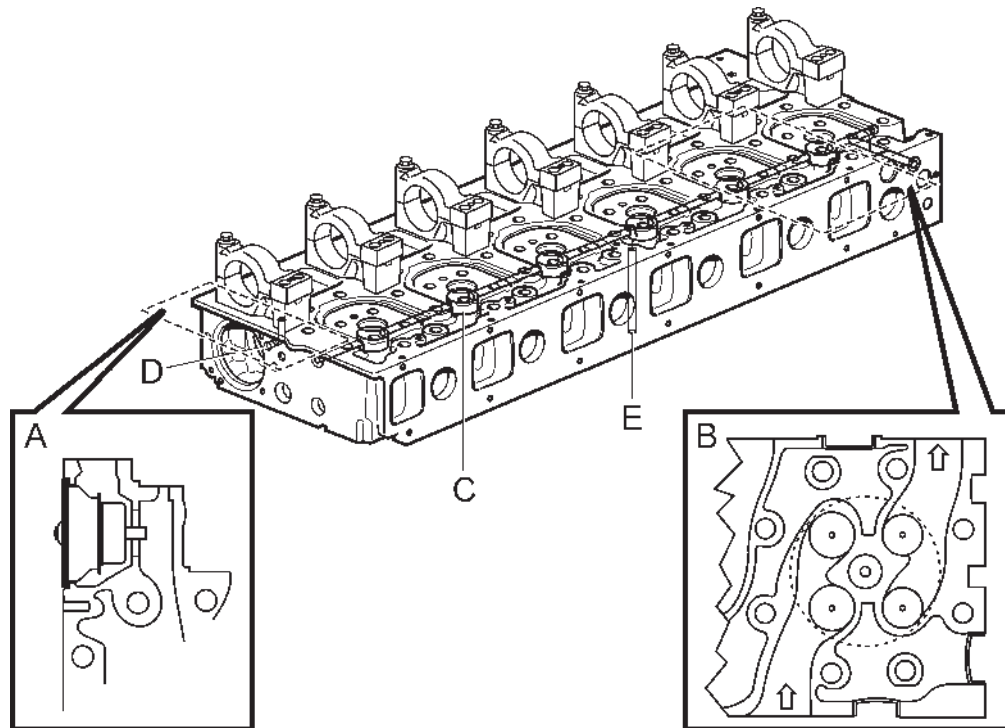

Cylinder head

The cylinder head is cast in one piece from a cast iron alloy to provide a stable bearing for the overhead camshaft.

The coolant thermostat housing is integrated into the cylinder head (A).

The cylinder head has separate inlet- and outlet channels with cross-flow for each cylinder (B).

The fuel channel to the unit injectors has been drilled lengthwise through the cylinder head and has a ring-shaped space around each unit injector (C).

The oil pressure in the rocker arm mechanism is measured in a channel at plug (D).

For camshaft and rocker arm lubrication, a channel has been drilled centrally in the left side of the cylinder head (E).

The valve guides are made of alloyed cast iron and all valve guides have oil seals. The valve seats are replaceable and made of steel.

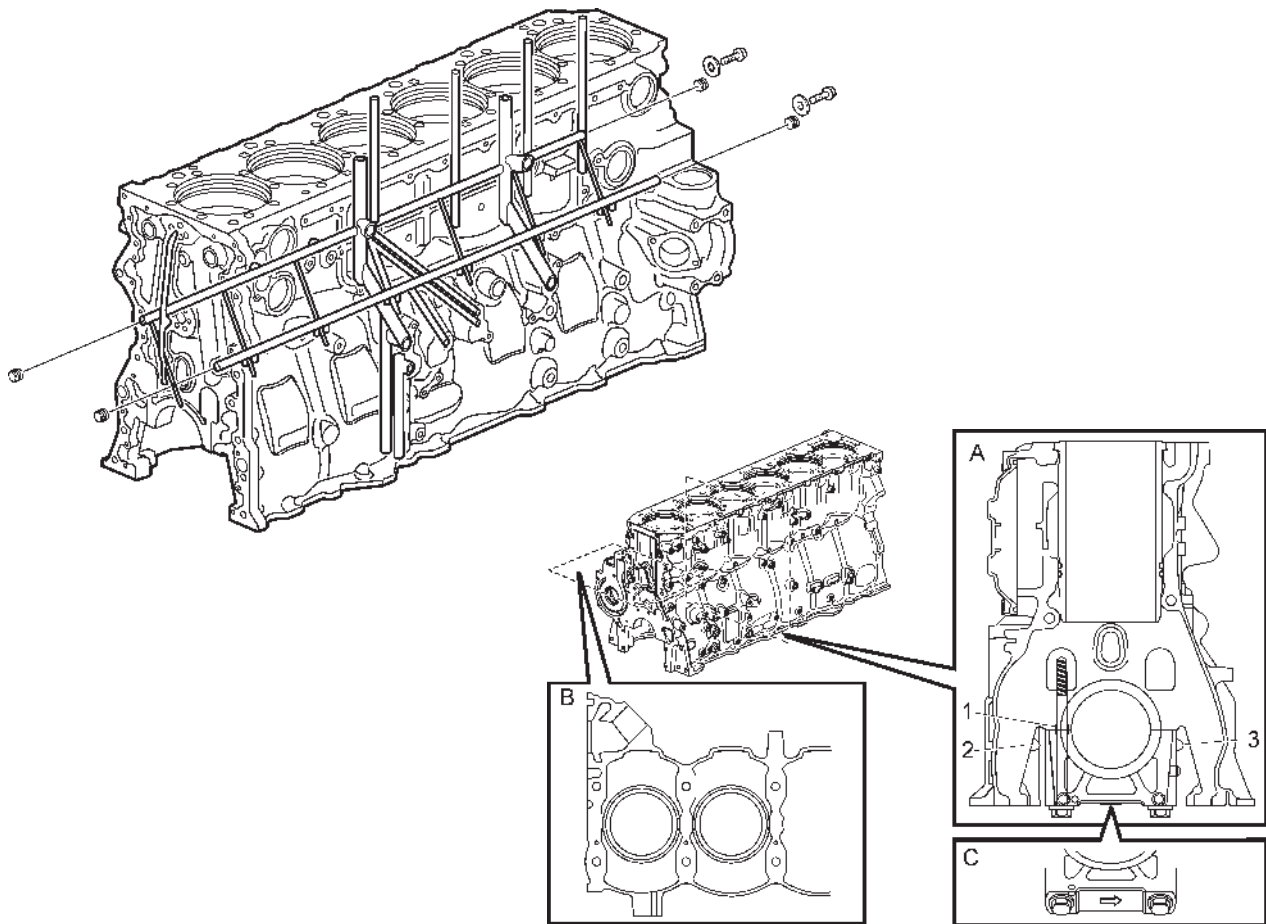

Engine block

The cylinder block is made of cast iron and cast in one piece. The cylinder block sides are cup-shaped around each cylinder in order to obtain high rigidity and good sound proofing.

All lubricating oil channels have been machined directly in the block. There are two longitudinal channels, on the right side of the piston cooling channel and on the left side of the main lubricating channel. The channels are plugged front and back. The rear face also has a channel for oil supply to the transmission.

At the lower level of the block, a bracing frame of 6 mm (0.236") steel plate is mounted to decrease vibrations and thus also engine noise.

The oil pan is made of plastic and mounted with 16 spring loaded screws in the cylinder block foot. The seal between block and oil pan consists of a rubber strip, in one piece, placed in a groove in the sump.

The cylinder block main bearing caps is guided by sockets pressed into the cylinder block (1). In order to avoid incorrect placement, the thrust bearing caps are numbered 1-7 and feature cast bosses in both blocks (2) and caps (3). The underside of the bearing caps are also marked with arrows, which should be turned towards the engine's inlet side.

The cylinder head gasket is made of steel in one piece, for the whole engine. The gasket incorporates vulcanized rubber seals for oil and coolant pass-through. The gasket also has a number of convex embossings in order for the cylinder to slide on the gasket during the fitting, and not damage the rubber rings in the gasket.

The cylinder head is lowered towards the guide pins in the cylinder block leaving a small distance to the transmission plate. The cylinder head is then pulled horizontally towards the transmission plate. When in place, it is screwed against the cylinder block and the embossings are flattened out.

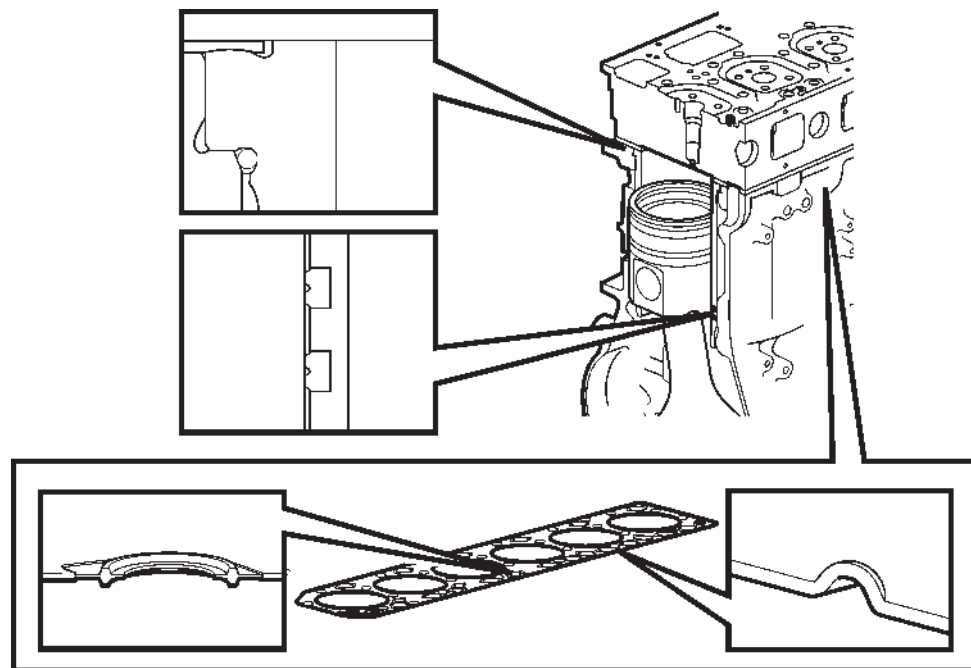

Cylinder liner

The cylinder block is equipped with wet, replaceable cylinder liners that are centrifugally cast of cast iron alloy.

The coolant space around the cylinder liners is sealed against the cylinder block with three sealing rings. The upper part is sealed by a ring below the liner collar.

The lower part of cylinder liner is sealed using two rubber rings. The top one, closest to the coolant, is black and the lower one towards the oil side is purple.

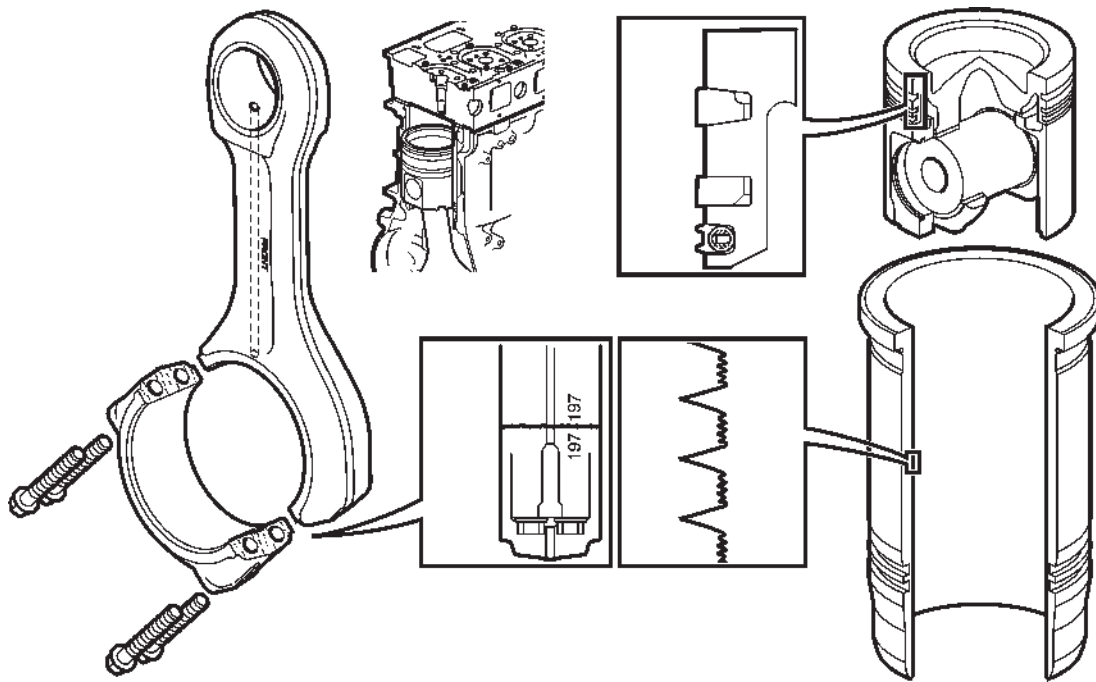

Pistons and connecting rods

Pistons are made of aluminum and have three piston rings; on top is a “Keystone” compression ring, in the middle a compression ring with rectangular cross-section and at the bottom a spring loaded oil wiper ring.

The connecting rods are forged and the lower crank bearing is “split” i.e. divided through a flat, unmachined surface.

The upper end features a pressed-in bushing that is lubricated via a drilled channel in the connecting rod.

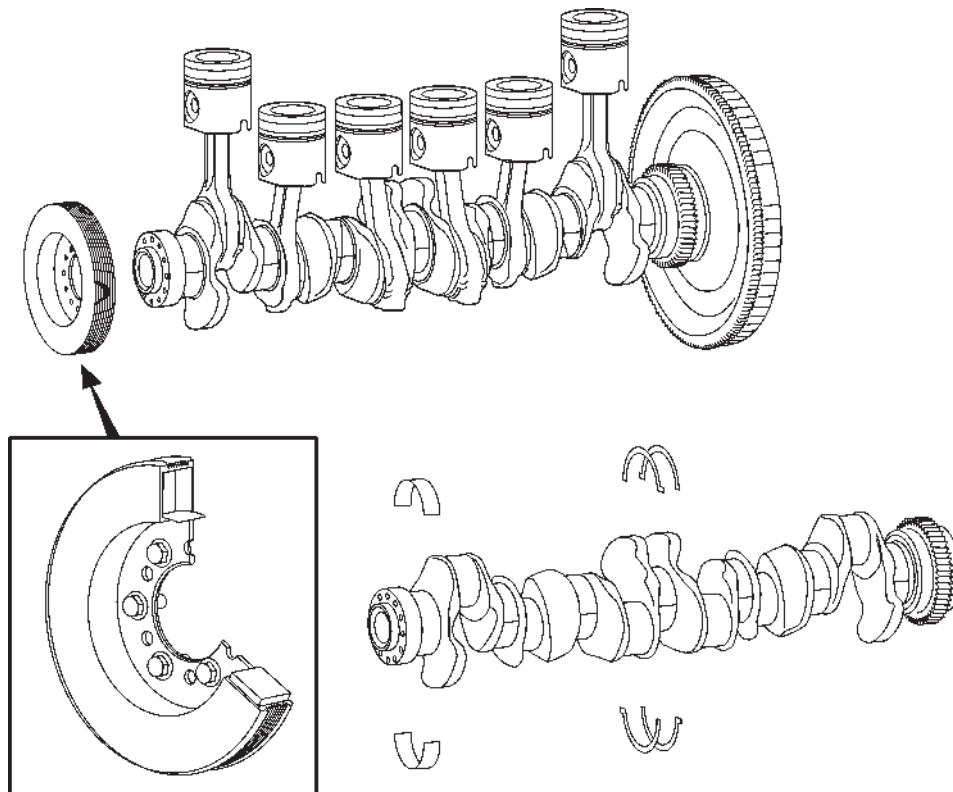

Crankshaft

The crankshaft is drop-forged in one piece and induction-hardened on the bearing surfaces for increased strength and decreased risk of cracks.

The crankshaft has 7 main bearings, each crank bearing is placed between two main bearings. The thrust bearings are located in the center main bearing. Both main bearings and connecting rod bearings have steel cups that are lead nickel plated and lined with lead bronze.

The crankshaft can be ground and has five undersize dimensions.

In the rear and the front the crankshaft has an integrated hub for attaching a transmission wheel (rear) and a vibration damper/belt pulley (front), respectively).

In the front cover cap, a Teflon seal seals against the crankshaft front end. The Teflon seal features an outer felt coating that protects against dust. In the vibration damper housing there is a freely rotating steel ring that works as inertial mass. Between the steel ring and the house the damper is filled with a high viscosity silicon oil. The vibrations are reduced by the oil equalizing the crankshaft's pulsating rotation and the steel ring's even rotation.

The crankshaft transmission wheel is placed on the rear end of the crankshaft. A guide pin on the wheel in the crankshaft prevents the wheel from being installed incorrectly. A sealing ring of silicone sealing between the crankshaft and the transmission wheel is situated on the crank shaft end.

The combined gear case/flywheel casing is located around the crankshaft transmission wheel. A Teflon seal seals between the flywheel casing and the crankshaft transmission wheel, with an outer felt coating that protects against dust.

The crankshaft transmission wheel features a guide pin directed towards the back that fits in the flywheel, so that it cannot be installed incorrectly. The flywheel bolts are fastened through the flywheel, the crankshaft drive and into the crankshaft.

The flywheel peripheral surface has a number of milled groves for the injection system speed sensor.

Lubrication is done via separate channels in the cylinder block to each main bearing and from there a channel runs to the nearest crank bearing pin.

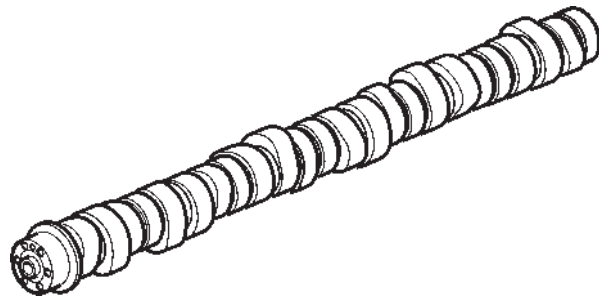

Camshaft

The overhead camshaft is induction-hardened. The bearing pins can be ground with replaceable bearing shells as spare parts.

The camshaft is journalled in seven bearing housings that are machined together and numbered 1-7, viewed from the engine front edge. The rear the bearing is a thrust bearing.

The camshaft has three tappets per cylinder. One for the intake valves, one for the exhaust valves and a tappet in the middle for the unit injector.

The camshaft drive is installed on the rear flange of the camshaft with a hydraulic vibration damper on the outside. Both the camshaft drive and vibration damper has holes for the guide pin from the camshaft in order to avoid incorrect installation. The vibration damper has teeth that signal the camshaft sensor.

A flange that shows the camshaft's mark, numbers 1-6 and TDC (Top Dead Center) is located in front of the rear bearing housing. TDC is used for the camshaft's initial setting and should be between the two lines on the bearing housing when the flywheel is at the 0° mark. The number marking are used when adjusting valves and injectors.

Screwed onto the camshaft cap is a rocker bridge. Journalled on it are rocker arms with pressed-in surface treated steel bushings. A valve caliper transfers the rocker arm movement to the valves. The rocker arm contact with the camshaft is carried out via a roller and against the valve caliper with a ball cup and an adjustment screw.

Exhaust valves have double springs.

The valve guides are made of alloyed cast iron and the valve seats are made of steel. Both are replaceable as spare parts. All valve guides are equipped with oil seals.

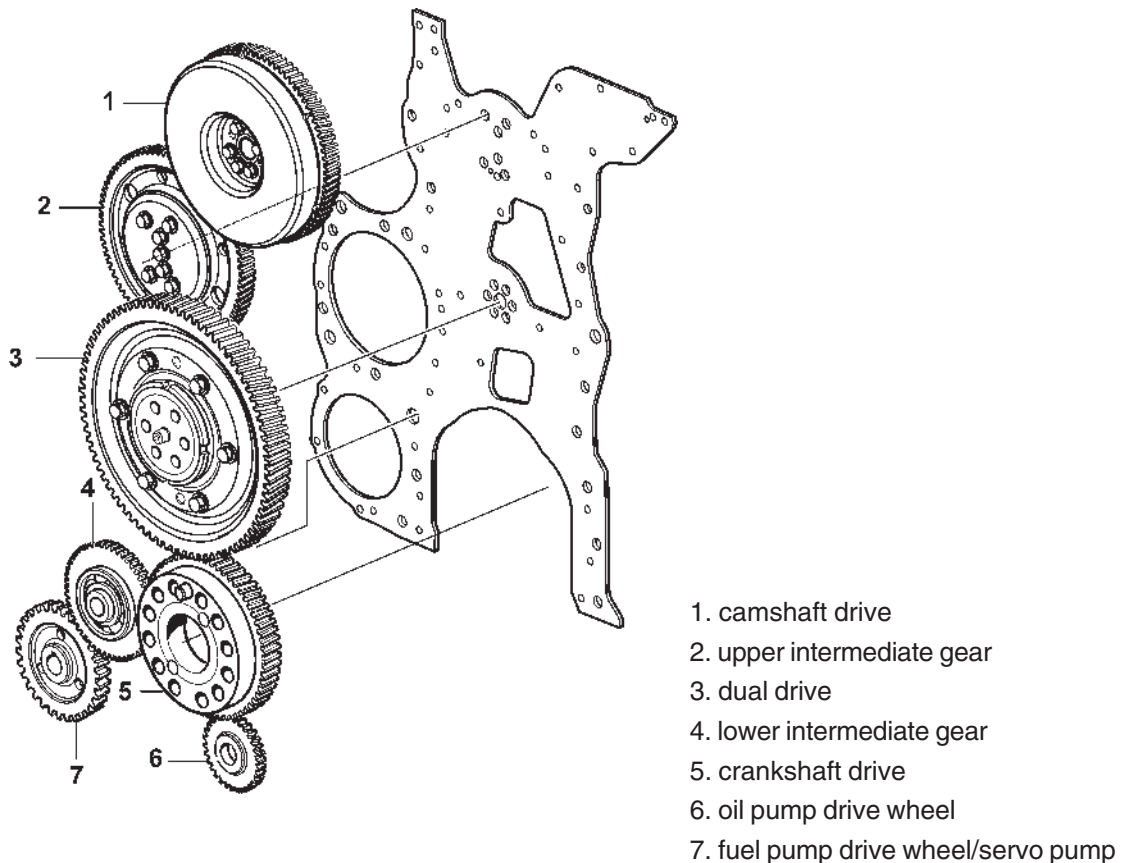

1. camshaft drive
2. upper intermediate gear
3. dual drive
4. lower intermediate gear
5. crankshaft drive
6. oil pump drive wheel
7. fuel pump drive wheel/servo pump

Transmission

The transmission is located at the rear edge of the engine on a 6 mm thick steel plate, which is screwed to the cylinder head and engine block, and fixed with two guide sleeves and a guide pin. All wheels are angle-cut and nitride hardened.

The crankshaft gear (5) also works as a spacers between the crank shaft flange and the flywheel. It is screwed on with 12 ea pass-through screws and fixed to the crankshaft with two socket head cap screws and a guide pin.

Above the crankshaft wheel is a dual wheel (3) consisting of two gears screwed together. The wheels are pre-installed on a hub journalled in two conical roller bearings. The inner wheel drives the upper (adjustable) intermediate gear (2) which in turn drives the camshaft wheel (1) and is journalled in a bushing on the hub.

The backlash shall be adjusted between the upper intermediate gear (2) and the camshaft wheel (1) when the transmission has been serviced.

Camshaft wheel (1) is screwed into the camshaft flange and controlled by a guide pin. The vibration damper with teeth for the camshaft sensor is installed on the outside.

The lower intermediate gear (4) is journalled in a two-row ball bearing and drives the combined fuel pump/servo pump. The wheel is fastened with a screw that runs through the flywheel casing and is threaded into the cylinder block.

Drive wheel (7) is installed on the servo pump pass-through shaft, which drives the fuel pump.

The oil pump drive wheel (6) is powered by the crankshaft gear.

Group 22: Lubrication system

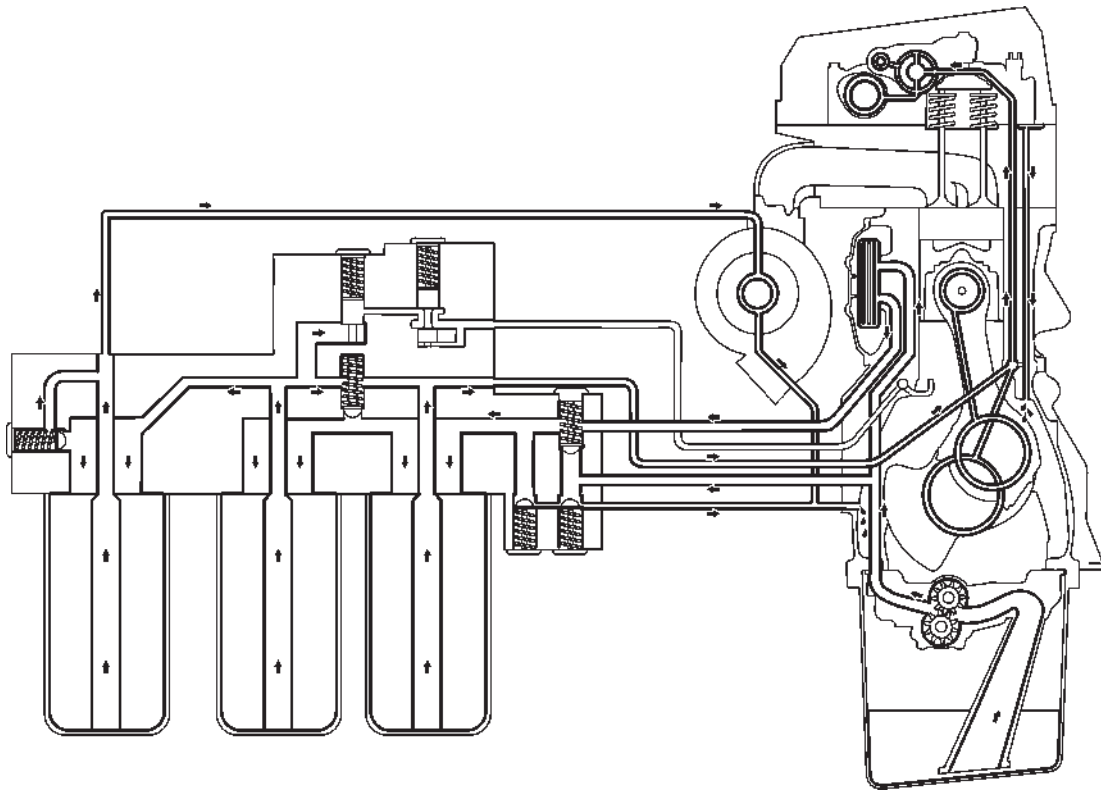

The engine is pressure lubricated by a gear wheel pump connect to the engine's transmission. The oil flow is controlled by 7 valves.

The lubricating oil pump is driven directly by the crankshaft gear and pressures oil to two full-flow filters and one by-pass filter (turbo filter). The by-bypass filter has low through-flow and a high degree of filtration.

Along the cylinder block, two channels are drilled, where the one in the left-hand side of the block is the lubricating oil channel that supplies all bearings on the crank mechanism with oil. The lubricating oil channel is plugged at both the front and rear.

The second channel, in the right-hand side of the block, is the piston cooling channel that supplies pistons with oil for cooling and lubrication. The piston cooling channel is plugged at both ends.

All bearings in the cylinder head are lubricated from the hollow rocker bridge connected with the cylinder block via a cast channel located centrally in the block.

The oil pump housing is made of aluminum. The pump is driven directly by the crankshaft drive. The oil pump housing and the two pump wheels are machined together and cannot be exchanged separately. The pump wheel shafts are journalled directly in the oil pump housing. Suction and delivery pipes are made of steel and are sealed against the pump cover and the oil dispenser house with rubber seals.

The pump housing is screwed into the cylinder block foot and acts as a bracket for the suction strainer, which is also secured to the bracing frame. The oil pump safety valve is located in the filter housing.

The oil cooler is of a flat type and placed on the right-hand side of the engine, on the inside of the cooling jacket side door and totally enclosed in coolant.

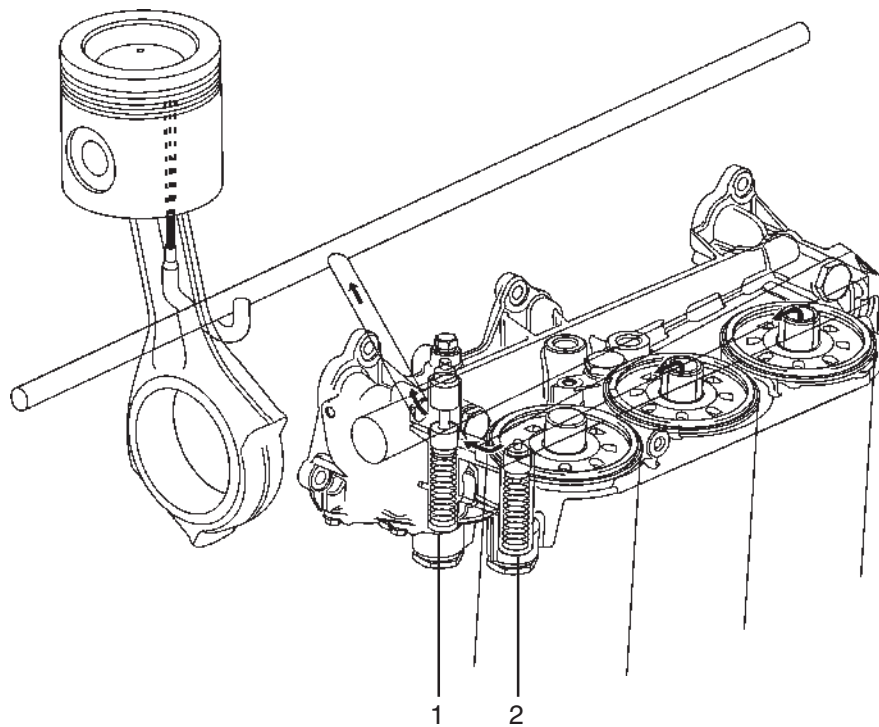

Piston cooling

Oil for the piston cooling is filtered through the full-flow filters, and is controlled by two spring loaded sleeve valves. Valve (2) senses the pressure to and from the piston cooling valve and is in direct connection with the filtered oil channel. Valve (1) is a control valve and gives a constant piston cooling pressure regardless of engine rpm.

The opening valve (2) is a spring loaded sleeve valve that opens and closes the oil flow. Opens at >2.5 bar, closes at <2.5 bar.

The pressure regulating valve (1) for piston cooling is a spring loaded sleeve valve. Oil enters through the lower chamber and passes the hole in the wall to the upper chamber. The pressure from the oil that is led upwards via the channel pushes the sleeve down. The sleeve waist controls the flow through the wall and thus piston cooling pressure, which is held constant.

The piston is cooled by oil using so called cavity cooling. The oil is sprayed vertically up in a channel in the piston via the piston cooling nozzle in the cylinder block. The oil then continues up to a circular channel in the top of the piston and is drained back to the oil pan.

Overview, valves

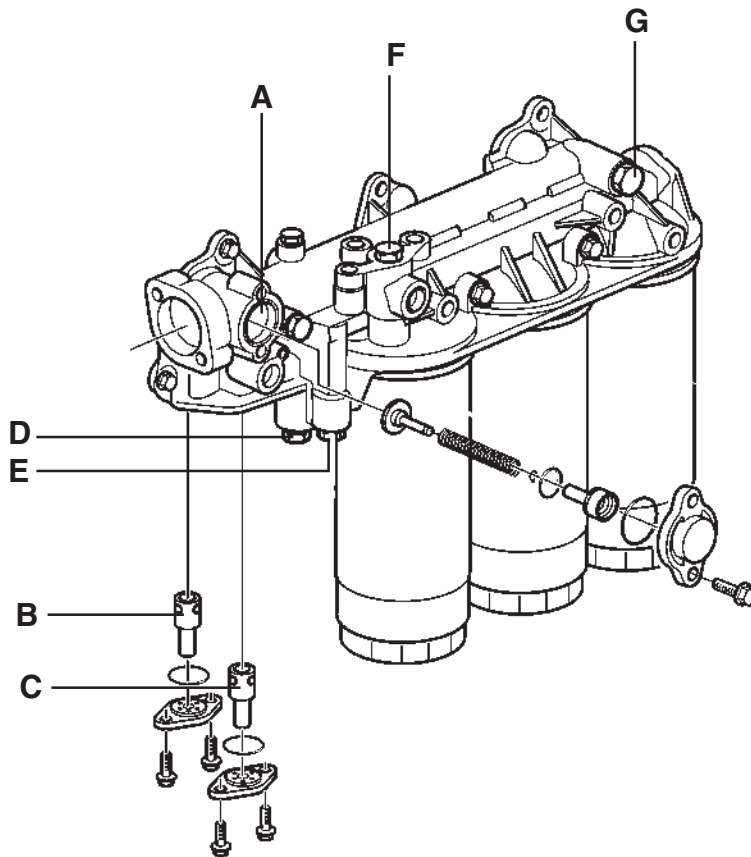

A: Oil cooler bypass valve

B: Safety valve

C: Reduction valve

D: Control valve for piston cooling

E: Opening valve for piston cooling

F: Bypass valve for bypass filter

G: Bypass valve for full-flow filter

Group 23: Fuel system

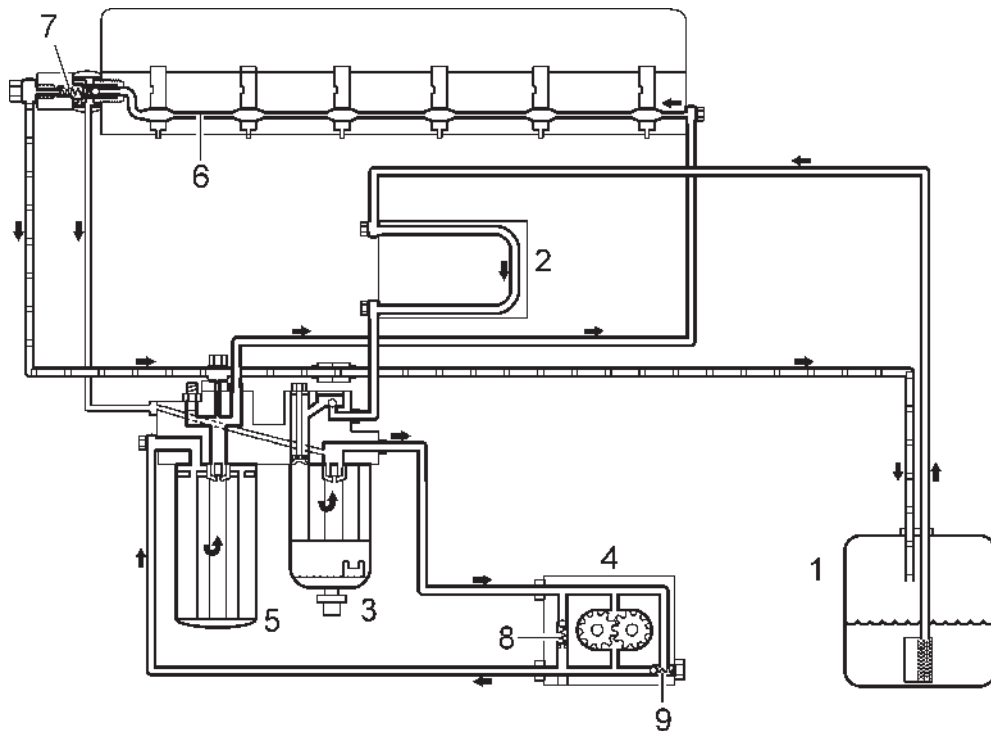

Each cylinder has an electronically controlled unit injector that works with very high pressure. The pressure is created mechanically via the rocker arms from the overhead camshaft. The injection itself is electronically controlled from the control module.

The fuel flows from the tank (1) to the control module's cooling coil (2), and from there through the fuel pre-filter (3) and on to the fuel pump suction side. The fuel pump (4) pushes the fuel to the fuel filter housing, through the main filter (5), up to the longitudinal cylinder head fuel channel. The fuel channel (6) supplies each unit injector with fuel via a ring-shaped space around each injector. The bypass valve controls the fuel pressure to the unit injectors. A check valve (7) ensures that the fuel does not flow back when the engine is shut off. The fuel then emerges at the front edge of the cylinder head, from where it flows down to the filter housing and is mixed with fuel from the suction side and fed back to the feed pump.

The feed pump has two valves. The safety valve (8) allows the fuel to flow back to the suction side when the pressure rises too high (such as when the fuel filter is clogged) and the check valve (9) opens when the hand pump on the pre-filter is used.

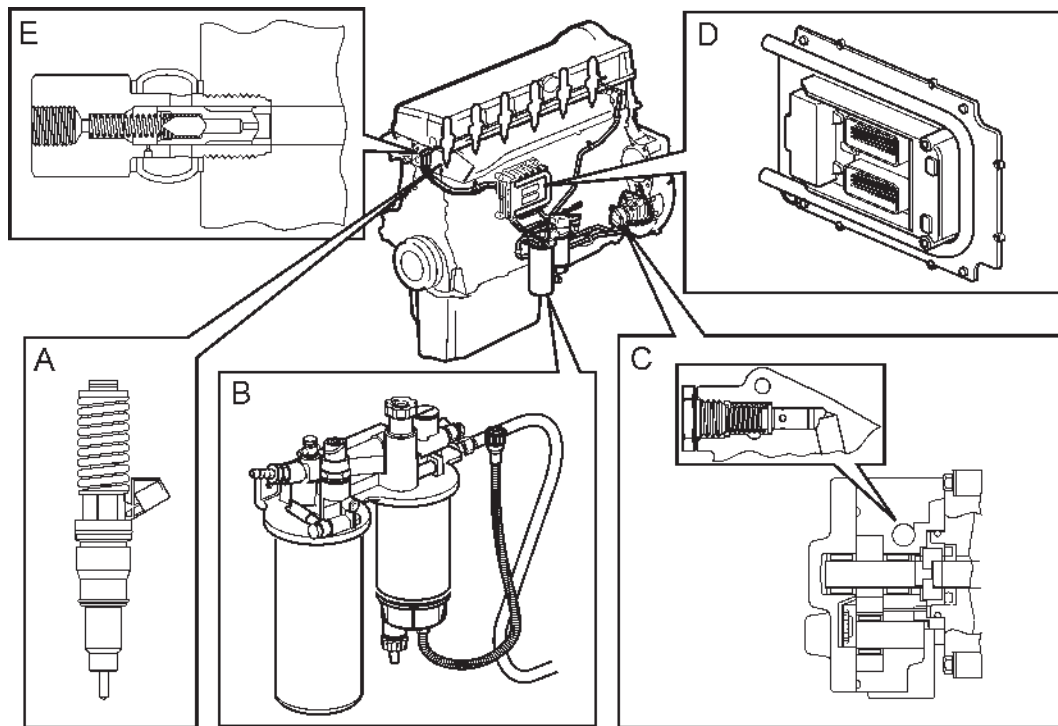

- A. The unit injectors are a combination of injection pump and injectors that works with much higher pressure than an ordinary injector. The opening pressure is about 320 bar (4,600 psi). The working pressure can be up to 2000 bar (29,000 psi). Injection timing and the amount of fuel to be sprayed is determined by the control module, which signals electromagnetic fuel valves built into the unit injector. The force on the unit injector is transferred via the rocker arm from a ridge on the camshaft.
- The unit injectors are made and classified by tolerance. Each unit injector is marked with a code on the top side of the electric connection. When replacing, the new codes shall be programmed.
- B. The fuel filter housing features an manual pump for venting the fuel system. Draining water takes place by hand at the water trap on the fuel pre-filter. A built-in check valve in the pump prevents the fuel from flowing back when the engine is shut-down.
- C. The gear type feed pump is driven by the crankshaft via an intermediate gear. High pressure is needed in order to ensure that the unit injectors are filled. The flow must be sufficient to even out any temperature differences in the cylinder head fuel channel.
- D. The control module is screwed to the engine with four vibration absorbing rubber blocks and is cooled by fuel through a cooling coil fastened on the outside of the control module, before the suction side of the feed pump.
- The control module receives information continuously from a number of sensors on engine in order to determine fuel quantity and time for injection. Control signals are sent through electric wires to the unit injector fuel valves. The control module stores any faults and deviations that occur in the system. Store occasional errors as well so you can trace them later.
- E. Excess fuel from the bypass valve is mixed with fuel from the suction side in the filter housing, and fed back to the feed pump.
- A hollow screw with an integrated bypass valve, which controls the feed pressure to the fuel system, is located in return line from the cylinder head. The opening pressure is 400-550 kPa (58-80 psi). The high feed pressure is needed to ensure that the unit injectors are filled. The bypass valve also has an integrated vent valve that automatically vents the system, allowing a small volume of fuel back to the tank.

Unit injector, work phases

The unit injector function can be divided into four phases;

- Filling phase
- Spill phase
- Injection phase
- Pressure reduction phase

The pump piston always pumps the same amount of fuel back and forth through the injector. It is only when the fuel valve is closed that the pressure builds up and injection takes place. The length and timing of the flow impulse determines the amount and timing of the spray, respectively.

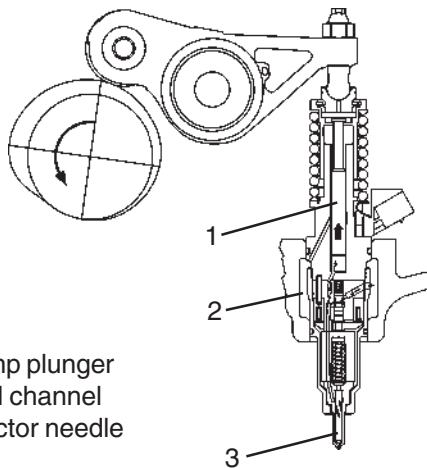

1. Pump plunger
2. Fuel channel
3. Injector needle

Filling phase

During the filling phase, the pump piston is on the way up to its top position.

The cam shaft ridge's highest point has passed and the rocker arm is on its way towards the camshaft basic circle.

The fuel valve is open since the solenoid valve has no voltage. Therefore, the fuel can be sucked from the fuel channel, past the fuel valve, and into the pump cylinder.

The filling continues until the pump piston has reached its top position.

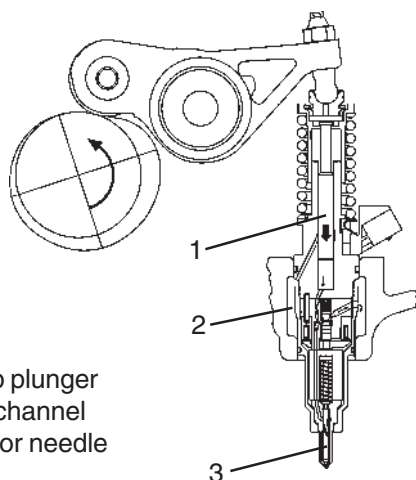

1. Pump plunger
2. Fuel channel
3. Injector needle

Spill phase

The spill phase starts when the camshaft has turned to the position when the camshaft ridge starts pressing the pump piston down via the rocker arm. The fuel flows back through the fuel valve and out into the fuel channel.

The spill phase continues as long as the fuel valve is open.

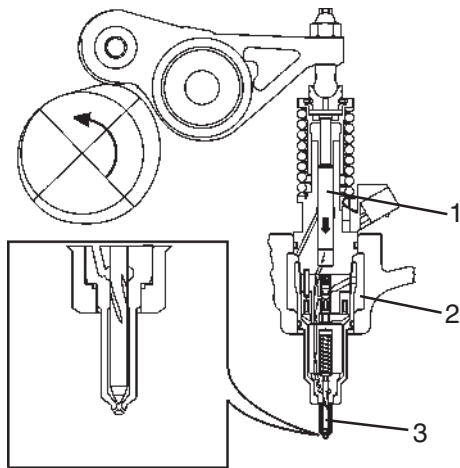

- 1. Pump plunger
- 2. Fuel channel
- 3. Injector needle

Injection phase

The injection phase starts when the solenoid valve receives a voltage from the control module and the fuel valve closes.

The camshaft ridge continues to press the pump piston down via the rocker arm. Because the passage through the fuel valve is closed, pressure builds quickly. The pressure lifts the injector needle and injection takes place.

The injection phase continues as long as the fuel valve is closed.

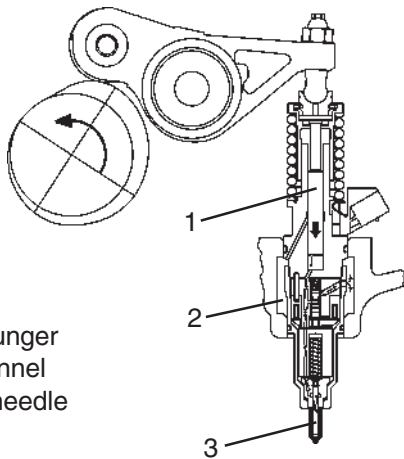

- 1. Pump plunger
- 2. Fuel channel
- 3. Injector needle

Pressure reduction phase

The pressure reduction phase starts when the control module determines that the engine has received the volume fuel it needs and then breaks the current impulse to the solenoid valve. The fuel valve opens and the fuel again flows back out into the fuel channel. The pressure drops fast and the injector needle closes so that injection is interrupted.

Group 25: Inlet and exhaust system

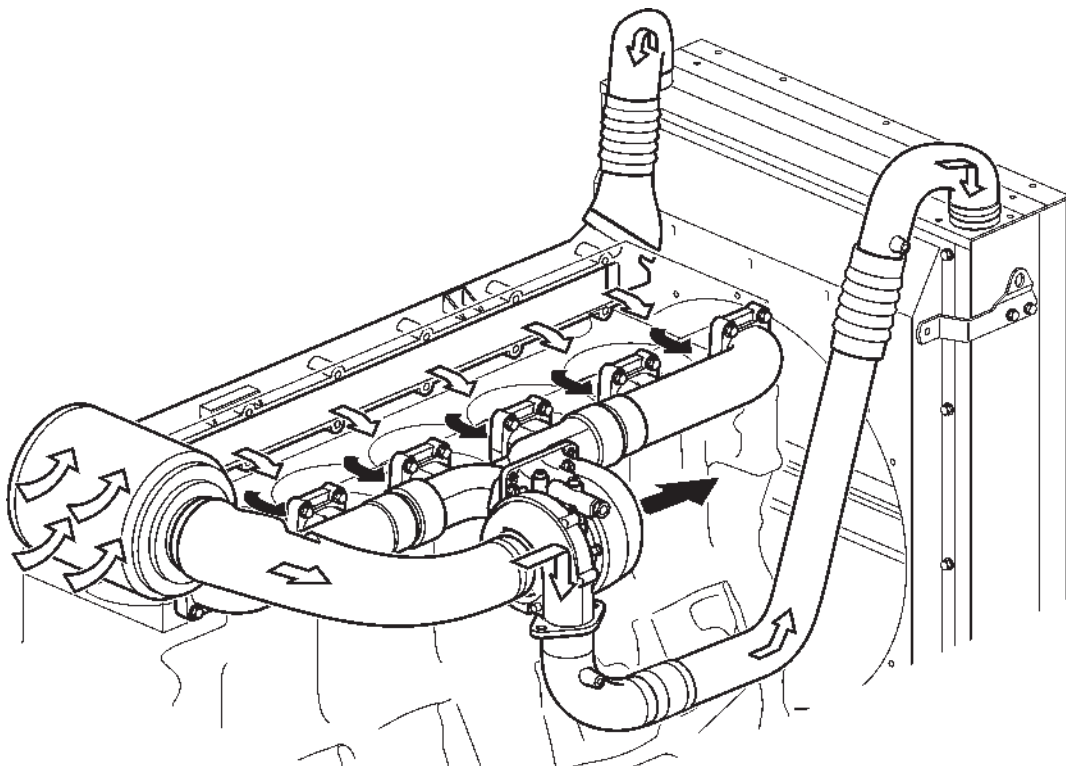

Turbocharger

The turbocharger is powered by the exhaust gases which pass through the compressor turbine housing on their way to the exhaust system.

The exhaust flow turns the turbine wheel and drives the compressor wheel which is installed on the same shaft. The compressor wheel spins in a housing which is connected between the air filter and the engine's inlet manifold.

As the compressor wheel rotates, air is sucked in from the air filter. Air is compressed and pressed into the engine cylinders after it first has been cooled while passing through the charge air cooler.

Group 26: Cooling system

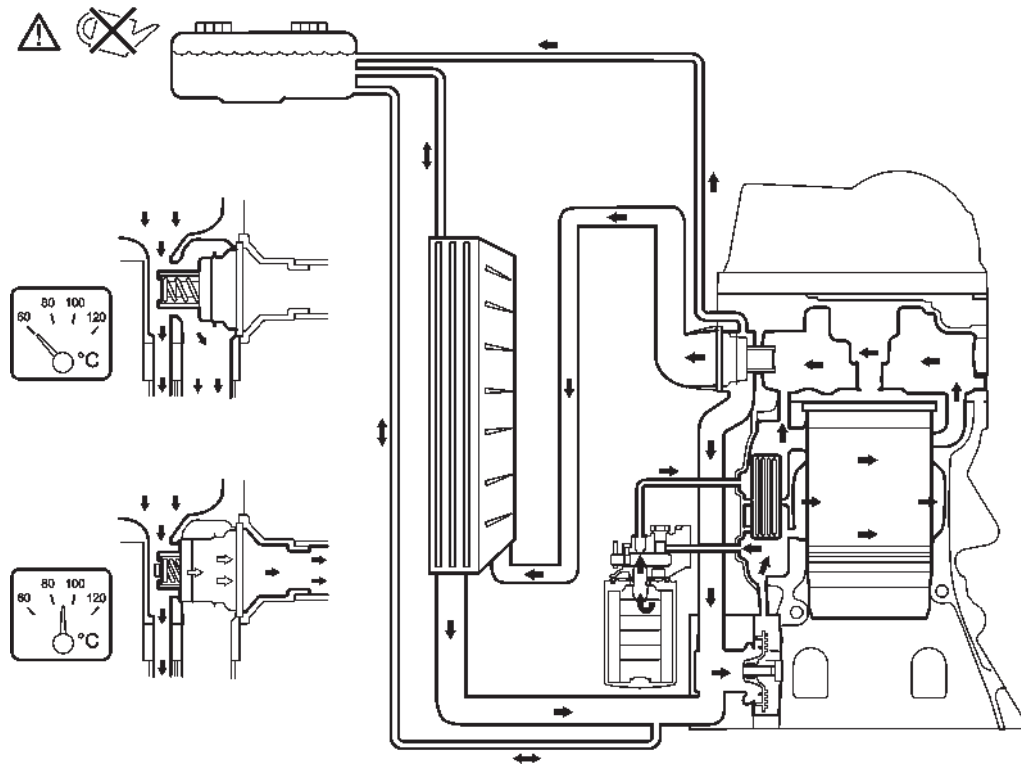

The coolant is pumped directly into the engine by the coolant pump from the pump housing on the right-hand side of the cylinder block. The main part of the coolant is pressed between the oil cooler flanges while some part is pressed into the cylinder liner lower cooling jackets.

After the oil cooler, the coolant is distributed via calibrated holes to the cylinders' upper cooling jackets and to the cylinder head. The cylinder head receives return coolant from the cylinder liner cooling jackets as well. This part of the coolant enters the cylinder head via nozzles that direct the fluid stream towards the outlet channels and the injector sleeves.

The thermostat housing is placed in the front end of the cylinder head. When the coolant is cold, the thermostat is closed and the coolant passes directly down through the thermostat housing to the coolant pump and back into the engine.

When the coolant is warm, the coolant is routed to the front outlet on the thermostat housing and to the inlet at the bottom of the radiator. Coolant is pressed down through the radiator while it is cooled, and then flows back to the coolant pump lower inlet. The coolant pump then pushes the coolant into the engine.

When the coolant becomes warm it expands and the excess is pressed up to the expansion tank. Any air in the coolant will be removed.

The thermostat is a so called piston thermostat with piston, transducer, seal and housing in one unit. It starts opening at 86° and is fully open at 96°.

The coolant pump uses an impeller and is driven by a belt from the crankshaft. The impeller is made from hard plastic. The servo pump shaft is journalled with a maintenance-free, double ball bearing. The seal between pump wheel and bearing is assured by a unit seal. Between seal and bearing there is a space with a drain channel that ends in a drain hole under the servo pump shaft. If the seal leaks, it shows by coolant leaking out through the drain hole. If so, replace the entire pump as a spare part.

Troubleshooting / Tests and adjustments

A number of symptoms and possible causes of engine malfunctions are described in the table below. Always contact your Volvo Penta dealer if any problems occur which you can not solve by yourself.

⚠ WARNING! Read the safety instructions for handling and service in the chapter “Safetyinformation” before starting work.

Symptoms and possible causes

| | |
|--|--|
| ☀ The diagnostic indicator is blinking | See Workshop Manual “(Group 23) EMS 2” |
| Engine can not be stopped. | 2, 5 |
| Starter motor does not rotate | 1, 2, 3, 4, 5, 6, 7, 8, 25 |
| Starter motor rotates slowly | 1, 2 |
| Starter motor rotates normally but engine does not start | 9, 10, 11, 12 |
| Engine starts but stops again | 9, 10, 11, 12, 14 |
| Engine does not reach correct operating speed at full throttle | 10, 11, 12, 13, 14, 22, 26, 27 |
| Engine runs roughly | 11, 12 |
| High fuel consumption | 13, 14, 16, 26 |
| Black exhaust smoke | 13, 14 |
| Blue or white exhaust smoke | 15, 16, 23 |
| Too low lubrication oil pressure | 17 |
| Excessive coolant temperature | 18, 19, 20, 21 |
| Too low coolant temperature | 21 |
| No, or poor charge | 2, 24 |

- | | | |
|---|---|--|
| 1. Flat batteries | 12. Water/contamination in fuel | 21. Defective thermostat |
| 2. Poor contact/open circuit in electrical cable | 13. Faulty unit injector | 22. Blocked intercooler |
| 3. Main switch turned off | 14. Insufficient air supply to the engine: – clogged air filter – air leakage between the turbo and the engine’s inlet pipe – dirty compressor part in the turbocharger – faulty turbocharger – poor engine room ventilation | 23. Too high oil level |
| 4. Cable harness box fuse broken | | 24. Alternator drive belt slips |
| 5. Faulty ignition lock | | 25. Water entry into engine |
| 6. Faulty main relay | | 26. High back pressure in the exhaust system |
| 7. Faulty starter motor relay | | 27. Break in “Pot+” cable to accelerator linkage |
| 8. Faulty starter motor/solenoid | | |
| 9. No fuel: – fuel cocks closed – fuel tank empty/wrong tank connected | 15. Excessive coolant temperature | |
| | 16. Too low coolant temperature | |
| | 17. Too low oil level | |
| 10. Clogged fuel fine filter or pre-filter (due to contamination, or paraffin precipitation in the fuel at low temperature) | 18. Coolant level too low | |
| | 19. Air in the coolant system | |
| 11. Air in the fuel system | 20. Faulty circulation pump | |

Operational disturbances

For additional information and more troubleshooting help, see “Coolant temperature, troubleshooting.” In case of an operational disturbance, check the following points first:

- Check that the coolant level is within markings on the expansion tank (at about 20 °C/68 °F). If the level is too low in the expansion tank, add coolant and start the engine. If the coolant disappears, there is internal or external leakage.
- Check that the coolant is not contaminated. If the coolant is contaminated, this signifies internal leakage (oil) **or** that the cooling system has blockage (deposits). A clogged cooling system is caused by one or more of the following factors:
- Coolant change has not been done as scheduled.
- Incorrect mix of coolant and water.
- Contaminated water has been used.

Clogging

High coolant temperature is most often due to internal or external clogging of the cooling system or a combination of both. If the cooling system is clogged, it must be cleaned. See “Radiator, outside cleaning” and “Cooling system, flushing”

- **External dirt:** Check that the cooler and/or the charge air cooler are not clogged.
Check for external or internal leakage in the cooling system.
- **Inner contamination:** Check that the cooler and/or the charge air cooler are not clogged. If you cannot see the light through at least one third, the cooler should be removed and cleaned.
- **External and internal leakage in the cooling system:** Check for leakage in the system.
- **Coolant circulation:** Check that the coolant circulates by allowing the engine to run at a high rpm. Check that the coolant circulates in the expansion tank too. This may be a clue if there is something wrong with the cooling system.
- **Thermostat:** Check the thermostat function. Drain enough coolant that the thermostat can be removed. Check the thermostat, see “Thermostat, testing”

Placement of instrument socket

The figures below show where instrument sockets may be placed on the engines.

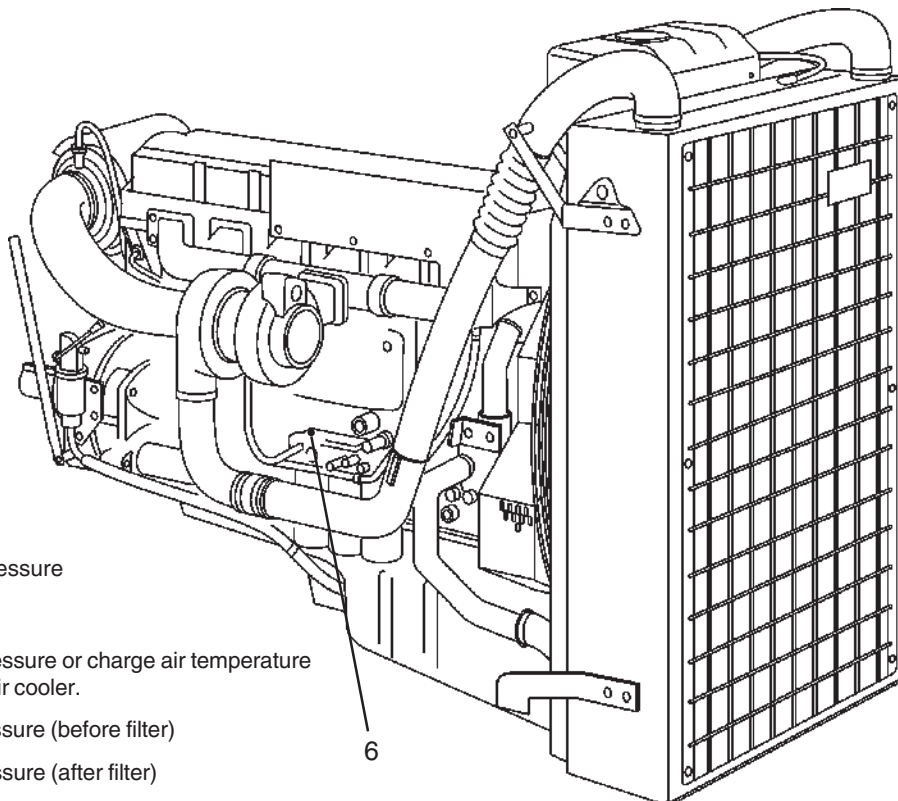
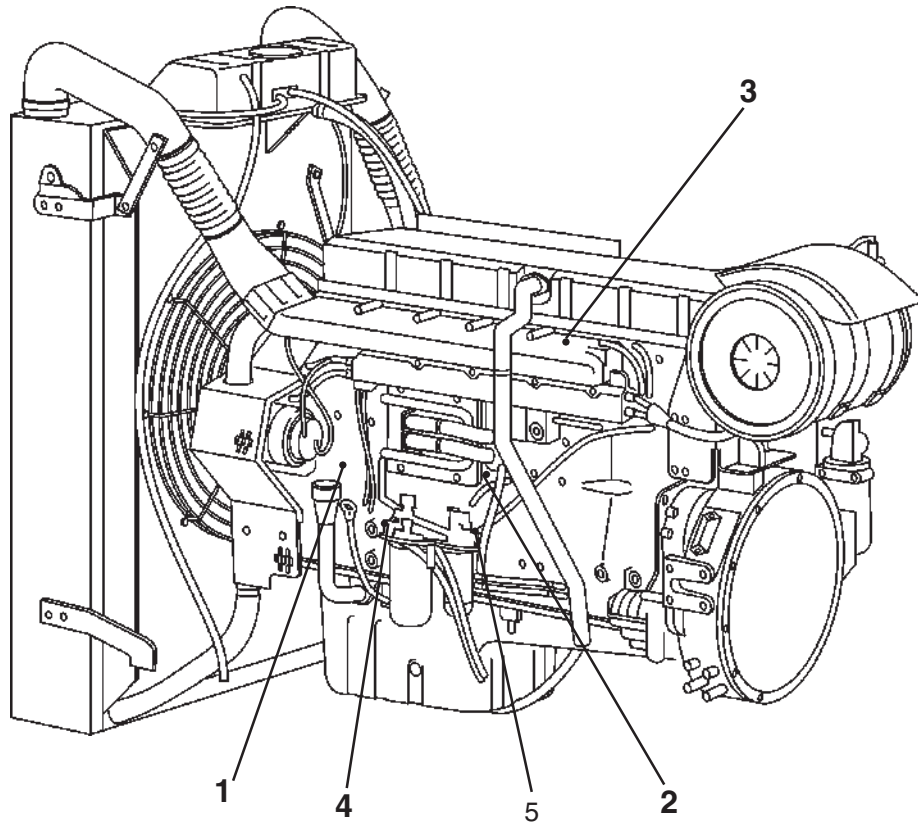

1. Crankcase pressure
2. Oil pressure
3. Charge air pressure or charge air temperature after charge air cooler.
4. Fuel feed pressure (before filter)
5. Fuel feed pressure (after filter)
6. Piston coolant oil pressure

Sensor overview

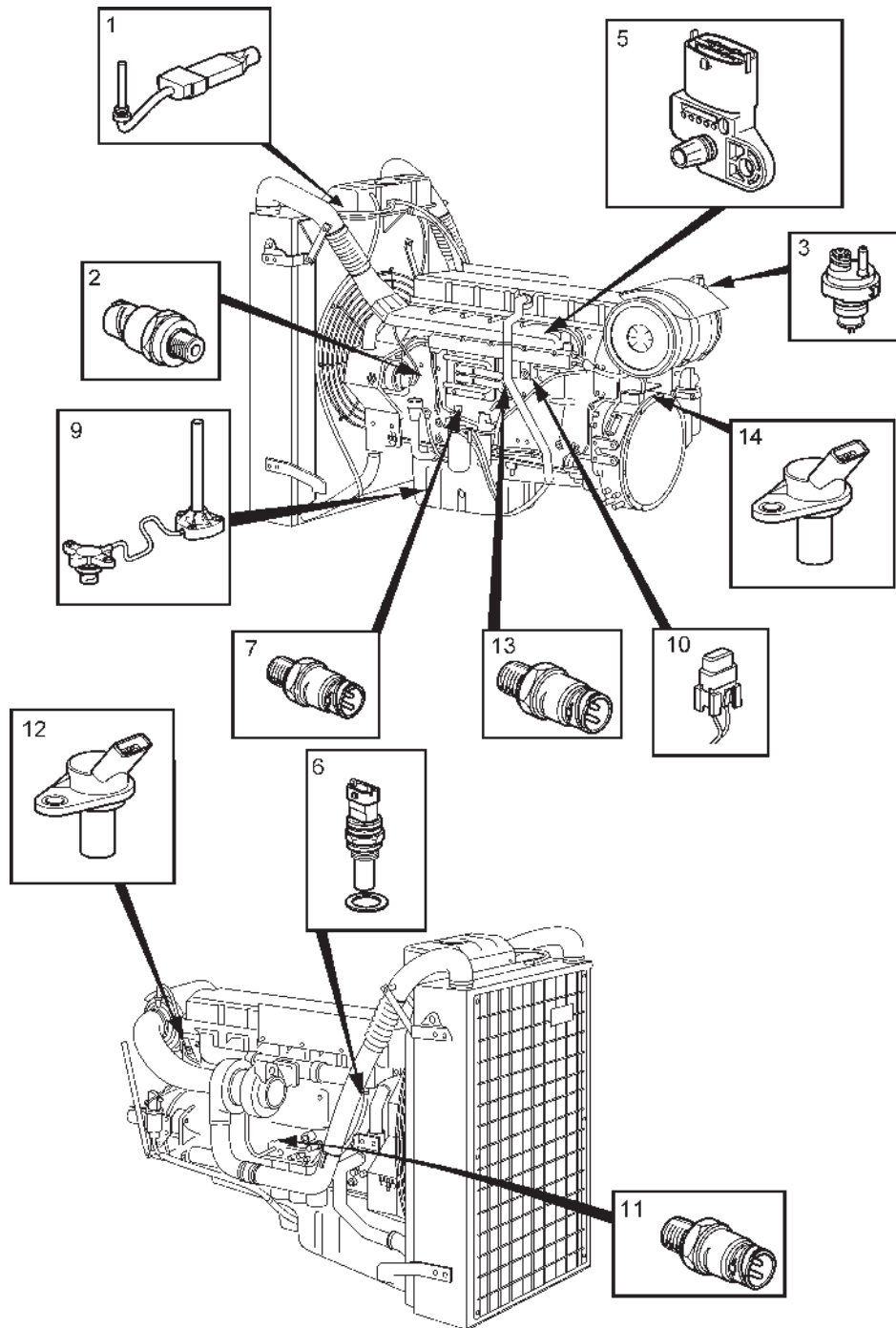

- | | |
|--|---|
| <ol style="list-style-type: none"> 1. Coolant level sensor, in the expansion tank 2. Crankcase pressure sensor 3. Charge air pressure sensor, air filter 4. Extra stop 5. Combined charge air pressure and charge air temperature sensor 6. Coolant temperature sensor 7. Fuel pressure sensor 8. Water in fuel sensor | <ol style="list-style-type: none"> 8. Solenoid valve, drainage, water trap (optional), not shown in illustration 9. Oil level sensor 10. Main circuit breaker 10 A 11. Piston coolant oil pressure 12. Camshaft position 13. Combined oil pressure and oil temperature sensor 14. Flywheel position and engine speed |
|--|---|

Compression test

21002

The fuel system is emptied and the rocker bridge removed.

NOTE! Empty the fuel channel in the cylinder head, see "Draining, fuel channel cylinder head" in chapter "Reconditioning / replacing components".

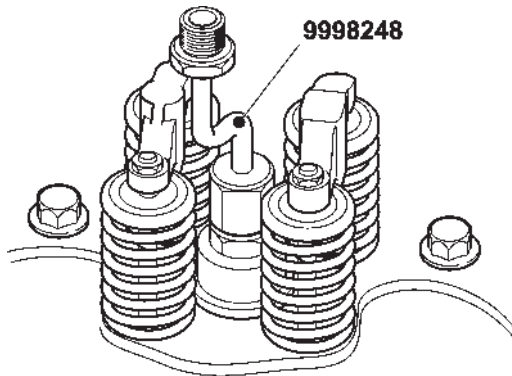

Special tools:

Lifting tool 9990185

Adapter 9998248

Compression gauge 9998539



1. Remove the unit injectors and clean the copper sleeves as needed.

IMPORTANT! Make sure that the area around the unit injectors is clean before they are removed.

2. Fit all adapters, 9998248, to the cylinder head. (This is in order to avoid repeating removal/refitting of rocker bridge and unit injector and performing valve adjustment.)
3. Oil valve caliper, cam shaft ridges and the rocker bridge.
4. Fit the rocker bridge with lifting tool 9990185. Torque the screws evenly along the rocker arm to avoid that the rocker arm bends or warps. Make sure that guide pins fit in the camshaft support bearing. Torque the rocker bridge as specified in "Technical data." Use torque wrench.
5. Install the middle piece and the oil pipe to the rocker bridge.
6. Check the valve clearance for all valves as specified in "Technical data."

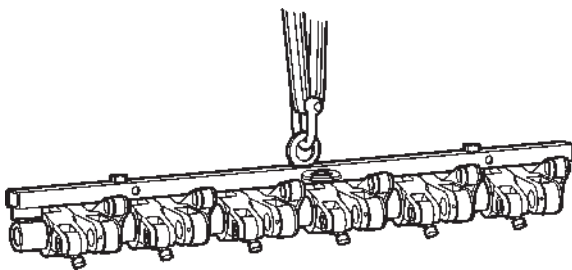

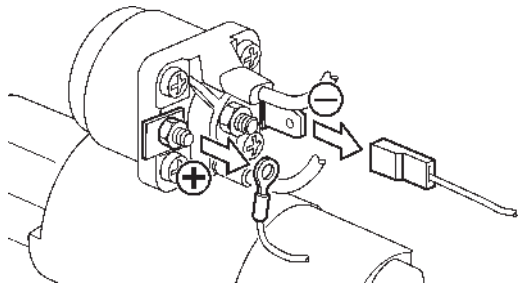

7. Remove both control wires from the starter motor control connector (the two thin cables). Connect one of the two free connectors on the control connector to ground.

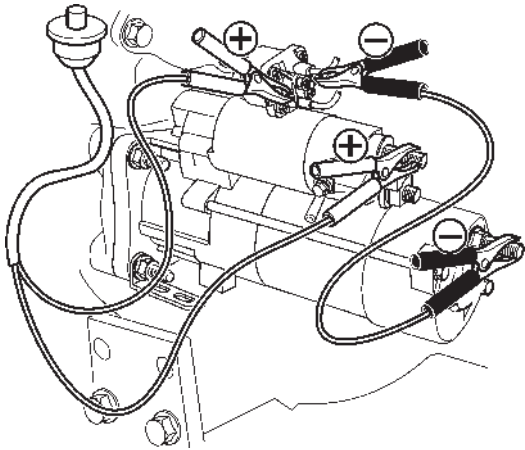

8. Connect the other connector to a switch, which in turn is connected to the positive (plus) connection on the starter motor.

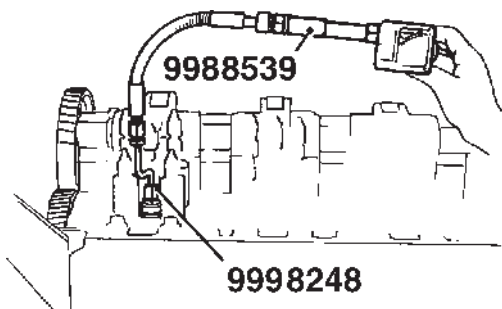

9. Connect compression meter 9988539 to adapter 9998248 on the first cylinder.

10. Run the engine with the starter motor until the compression meter needle has stopped (max compression reading) and read the value.

Repeat the test on all cylinders.

NOTE: Do not run the engine for more than 15 seconds at a time with intervals of 60 seconds.

11. Remove the middle piece and the oil pipe for the rocker bridge.

12. Remove the rocker bridge screws equally in stages so that it is not bent. Remove the bolts and carefully lift off the rocker bridge using lifting tool 9990185.

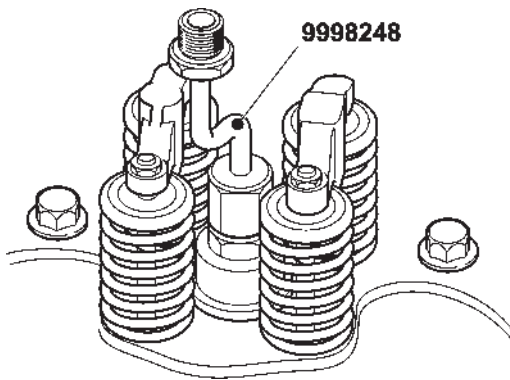

13. Empty the fuel channel in the cylinder head, see “Draining, fuel channel cylinder head” in chapter “Reconditioning / replacing components”.
 14. Remove adapters 9998248 from all cylinders.
 15. Fit unit injectors, with new o-rings. See “Unit injector, replacing.”
Fit the rocker bridge.
- NOTE:** Torque the screws evenly along the rocker arm to avoid that the rocker arm bends or warps.
Adjust valves and unit injectors. See “Valves and unit injectors, adjusting”
16. Vent the fuel system. See “Fuel System, bleeding”

Cooling system, pressure-testing

Special tools:

Cover with connecting nipple 9996441
Pressure testing device 9996662

Check the pressure testing device 9996662 before using it. See "Cylinder head, pressure testing."

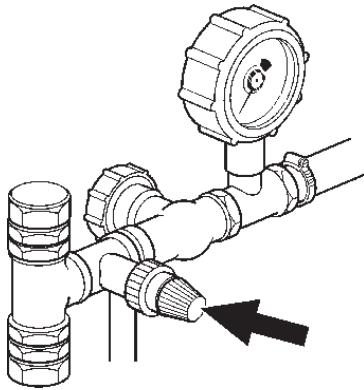

1. Check that all hoses are free from defects.
2. Check that the cock on the pressure reduction valve is fully opened.

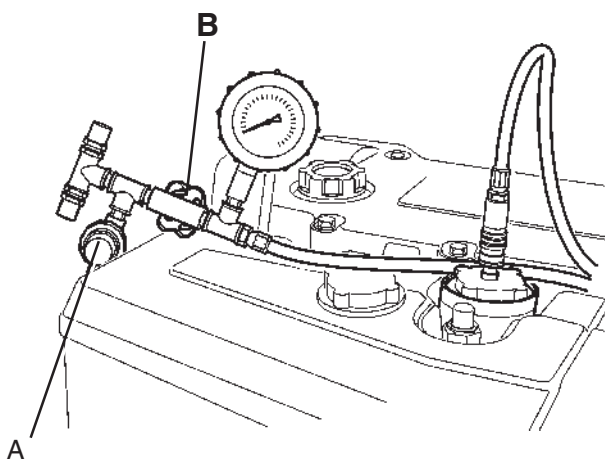

3. Replace the coolant filler cap on the expansion tank with cap 9996441. Connect the pressure testing device to the nipple on the lid.
4. Connect the pressure-testing device to the compressed air system and open the cock (B). Adjust the pressure reduction valve (A) so that pressure gauge shows a pressure of **70 kPa (10.15 psi)**. Close cock (B).
5. The pressure must not drop during **two minutes** for the cooling system to be considered free from leaks.

NOTE: Repeat the pressure testing if you are uncertain whether the cooling system leaks or not.

6. Close the compressed air after the pressure testing. Eliminate the excess pressure in the cooling system by unscrewing the pressure reduction valve and opening the cock (B).
7. Remove the testing device.
8. Check coolant level in the expansion tank. Install the regular coolant filler cap.
9. Start the engine and check for leaks.

Boost pressure, troubleshooting 25502

Charge air pressure, checking

Special tools:

| | |
|-------------------------|---------|
| Connecting nipple | 9996666 |
| Hose | 9998493 |
| Pressure gauge | 9998339 |

1. Connect the nipple with hose and pressure gauge to the measurement outlet on the inlet manifold, see "Location of measurement outlet."
2. Compare the pressure with the value that can be read off from the VODIA tool, see "Workshop manual, EMS 2"
If the two values differ, the pressure sensor is faulty and must be replaced.

Boost pressure, troubleshooting Pressure drop indicator, checking

1. Check that the air filter is clean and that there are no obstructions for the intake air.
2. Remove the pressure drop indicator from the air filter housing
3. Check the pressure drop indicator by sucking air until the dial indicator shows red. Reset the fuse by pressing the yellow top.
4. When the air filter is clogged, for example, and vacuum is created, the pressure drop indicator shows red. Replace dial indicator if it does not work as in point 3, above.
5. Install the pressure drop indicator on the air filter housing

Exhaust system, checking

1. Check that the exhaust system is Volvo Penta original.
2. Check if exhaust system has been rebuilt, is bent or has damage that prevents the exhaust from getting out.
If the exhaust system is not a Volvo Penta original, has been rebuilt or damaged, the exhaust backpressure may be too high, which leads to less engine output.
3. If you suspect that the exhaust back pressure is too high the pressure should be checked, see "Exhaust back pressure, measurement

Charge air cooler, checking

1. Check the charge air cooler for damaged cells or connections.
If it is damaged, replace the charge air cooler.
2. Check the charge air cooler and radiator for external clogging.
In case of clogging, clean per "Radiator, outside cleaning."

Inlet pipe, checking

1. Check that the intake manifolds are clean and undamaged inside. Squeezed, damaged or dirty inlet pipes may cause the boost pressure to become lower.

Air intake pipe, checking

1. Check the charge air pipes for visible cracks and external damage.
2. Check for oil in charge air pipes. If the pipes has damage or leakage in sealing rings at connections, the boost pressure will be too low and the engine's output deteriorates.
If the pipes are contaminated by oil inside, this points to oil leakage at the turbo's turbine shaft seal. In that case, replace the turbo complete.

NOTE: If there is oil in charge air pipes and charge air hoses, the charge air cooler and all pipes and hoses in the charge air system should be very thoroughly cleaned inside, before the engine is started.

Turbocharger, checking

25507

1. Check that the turbo unit item number is matches the engine version. The wrong turbo unit for the engine version may provide charging pressure that is too low and thus reduce the engine's output.
2. Check that turbo unit has the correct compressor housing. If the wrong compressor housing is installed on the turbo, the compressor wheel may have been damaged or have too big clearance between wheel and housing. In both cases the boost pressure becomes too low.
3. Remove the intake manifold from the turbocharger.
4. Check the turbo for damage on compressor wheel and for big axial play on the turbine wheel shaft.
5. In case of damage to compressor wheel and excessive axial play, the turbo should be replaced complete.
6. Remove exhaust pipe (muffler) from the turbo and check the turbine wheel.
7. Check the turbine wheel for damage. If the turbine wheel has been damaged, replace the entire turbo.

Exposing engine

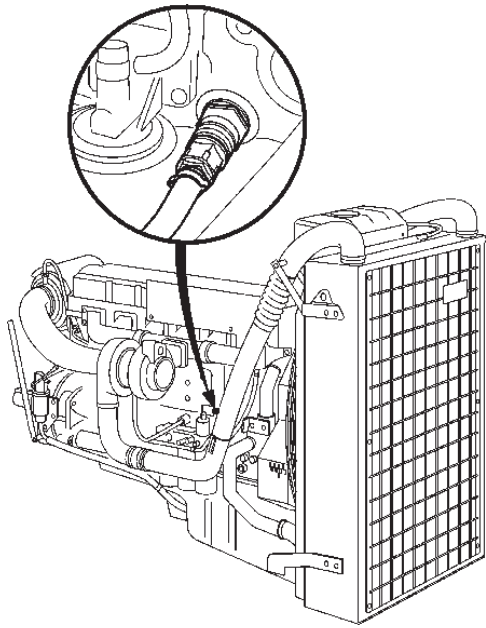

1. Drain the coolant, see “Cooling system, draining.”
Drain engine oil.

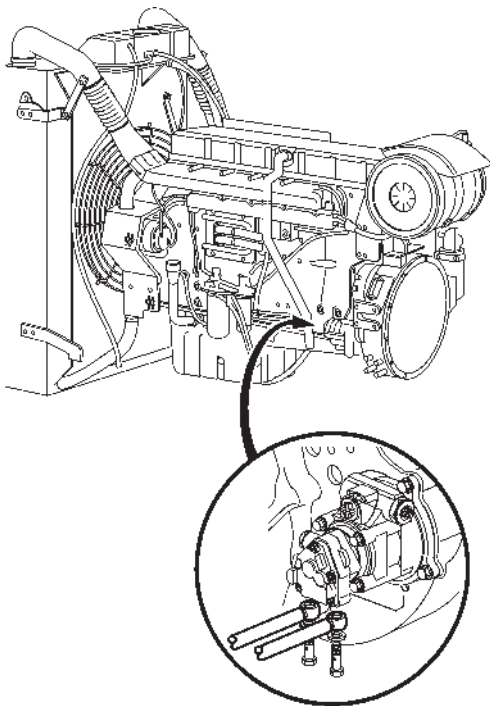

2. Remove fuel connections to the fuel pump and allow the fuel to flow out into a suitable container.
3. Remove the hoses from the radiator and the expansion tank.
4. Remove heat shield above the turbo, if any.

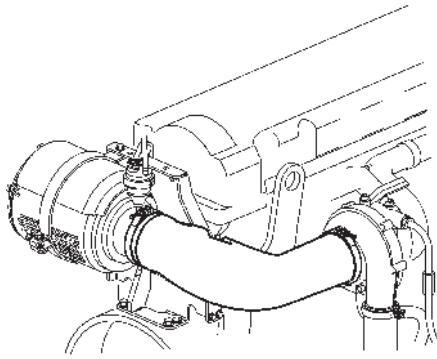

5. Remove the air filter sensor.
6. Remove the pipe between the air filter and the turbo. Cover all openings.
Remove the air filter housing and mounting bracket.

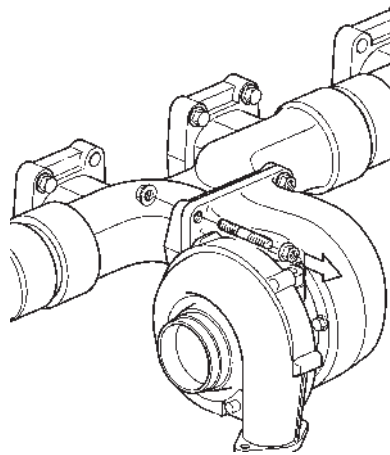

7. Remove muffler and brackets, if any.
Remove the turbo from the exhaust pipe and the two the oil pipes.
Cover the turbo opening.

8. Remove the crankcase ventilation with its bracket and oil separator.
9. Remove the pipe between the charge air cooler and the intake manifold. Cover all openings.
10. Remove safety cover above alternator, if any.
11. Remove the radiator fan safety cover/screen and remove the fan, the hub and its brackets to the cylinder head.
12. Remove the coolant pipe from the thermostat.
13. Remove protective plate and drive belts.

Fixture fitting

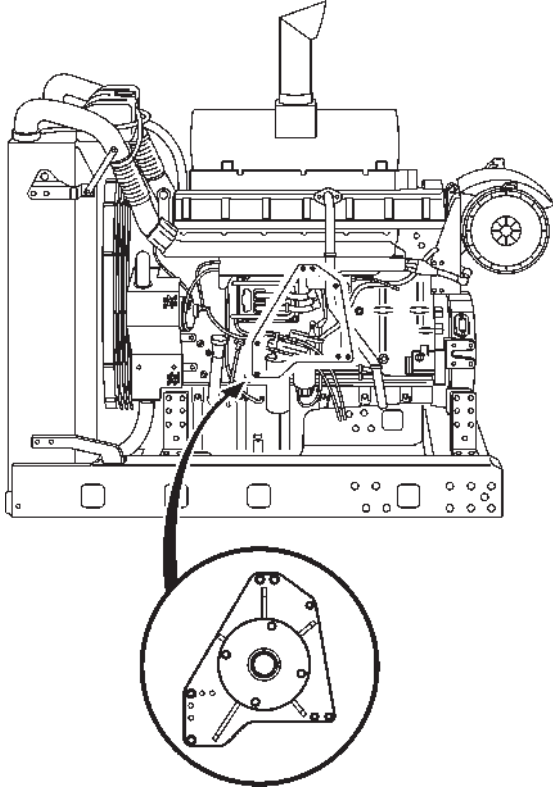

1. Remove distributor above the control module
2. Remove cable harness and fuel lines to the control module. Cover all openings.
Remove the control module.
3. Remove fuel and electrical connections. Lift the fuel filter bracket together with the filters.
Cover all fuel connections.
4. Install fixture 9990143 with 7 screws.

Engine body, general overhaul

Cylinder head, removal

The engine exposed and installed on stand, coolant and fuel drained.

1. Remove the rear lifting eye/mounting bracket.
2. Remove the heat shields above the turbo, if this was not done when the engine was exposed.
3. Remove the oil pipes between the turbo and the oil filter bracket and the engine block, respectively.
Cover all openings.

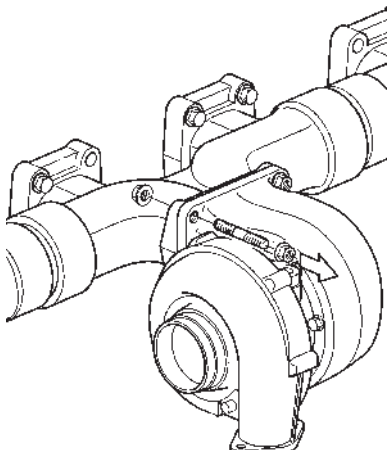
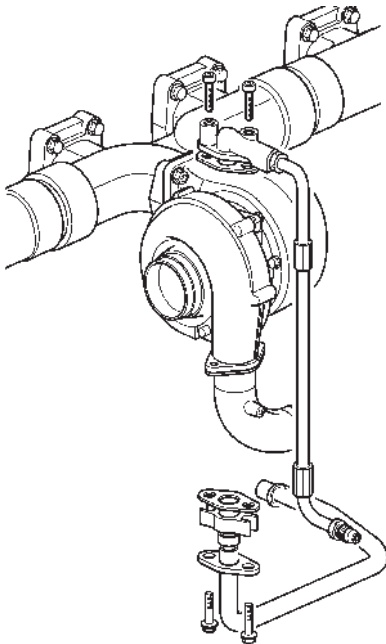

4. Cover the turbo exhaust port and remove the turbo.

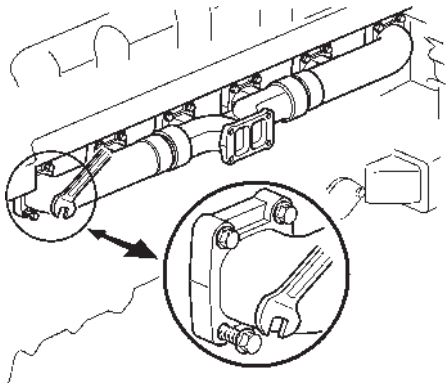

5. Remove the exhaust manifold.

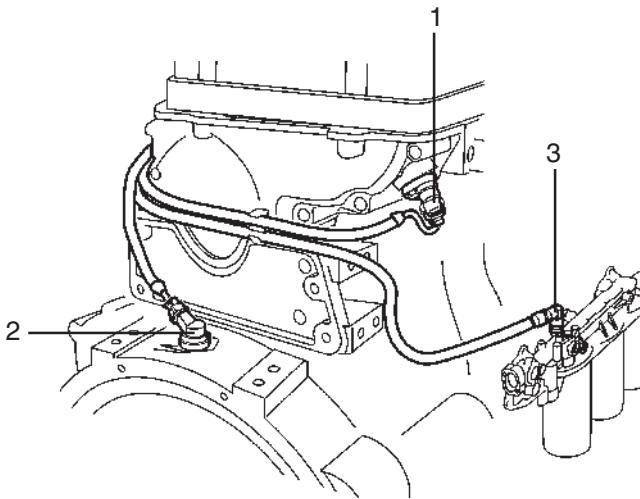

6. Remove the camshaft sensor (1), the flywheel sensor (2) and the sensor on the oil filter bracket (3). Remove the cable harness from sensor and starter motor.

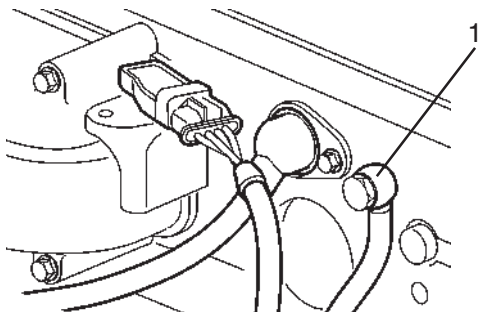

7. Remove the fuel lines to the cylinder head (1) and plug connections.

8. Remove valve cover and crankcase ventilation.



9. Clean around the unit injectors and remove the contacts for the unit injectors. Remove cable holders together with cable harness.

Cut off cable ties and remove the cable harness from the cable holder.

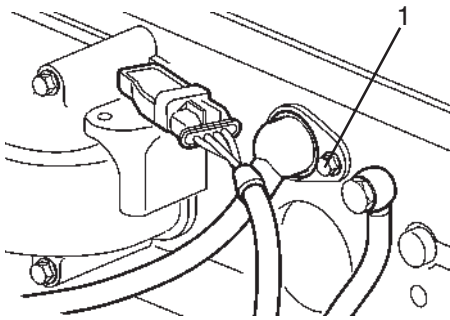

10. Remove the screw for the cable bushing (1) and carefully pull out the cable harness through the cylinder head.

⚠ IMPORTANT! Remove on the screw, **do not split** the cable bushing.

11. Remove the contact to the coolant sensor, the hoses to the expansion tank and the rest of the cable harness and lift it away.
12. Remove the return fuel lines on the cylinder head front edge and plug the connections.

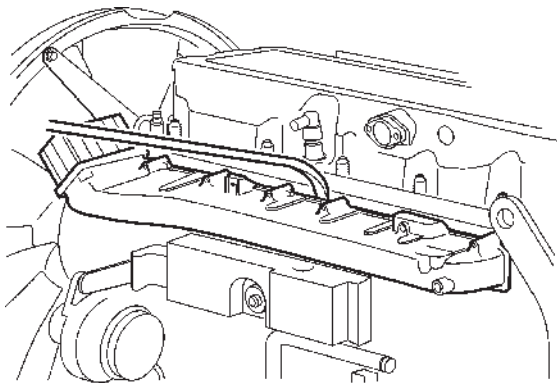

13. Remove cables from any preheater on the intake manifold.
14. The intake manifold must be removed if you are going to use fixture for cylinder head, 9990160. Remove all screws and remove the intake manifold using crowbar 9998511 against the reinforcement bosses.

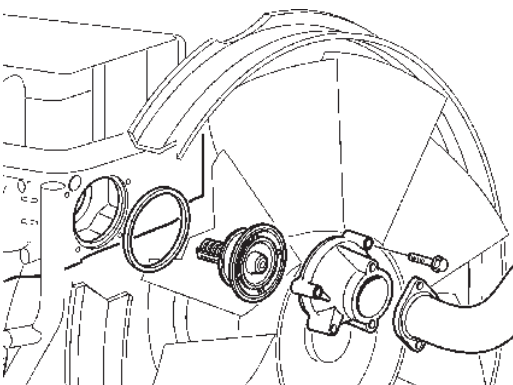

15. Remove the thermostat housing and the thermostat.
Remove the front lifting eye.
16. Remove the screws from the coolant pipe and the hose clamp from the coolant hose.

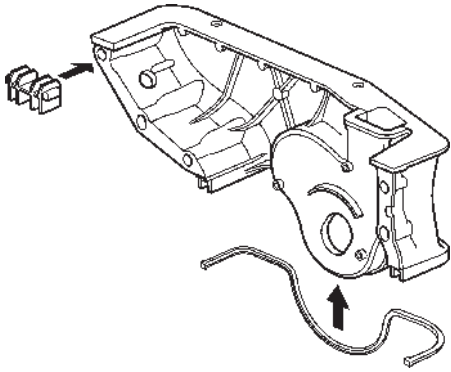

17. Remove the upper transmission gear casing and remove the rubber seals.

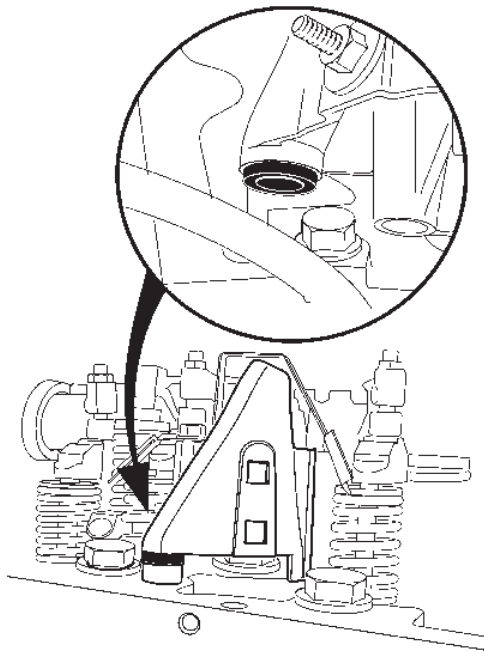

18. Remove the middle piece for lubrication of the rocker bridge, together with the delivery pipe.

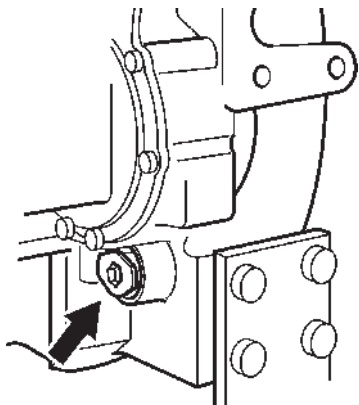

19. Remove the cover lid in the flywheel casing and attach turning tool 9993590.

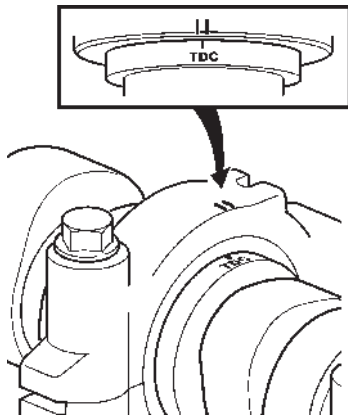

20. Turn the engine to TDC on the camshaft, check that the mark on the flywheel is at "0."

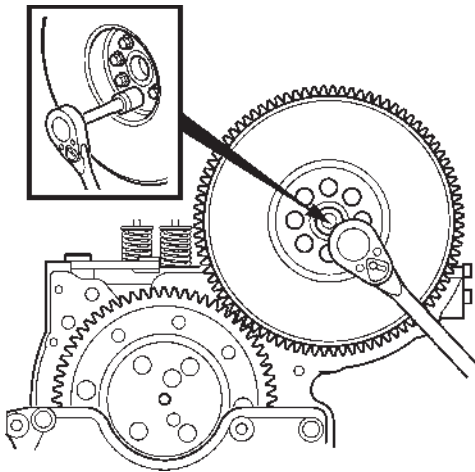

21. Remove the camshaft drive together with the vibration damper.

NOTE: The vibration damper is very sensitive to shocks.

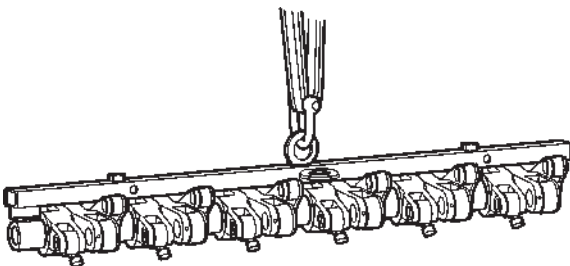

22. Remove the rocker bridge screws alternately to avoid uneven load.
23. Lift the rocker bridge using lifting tool 9990185.

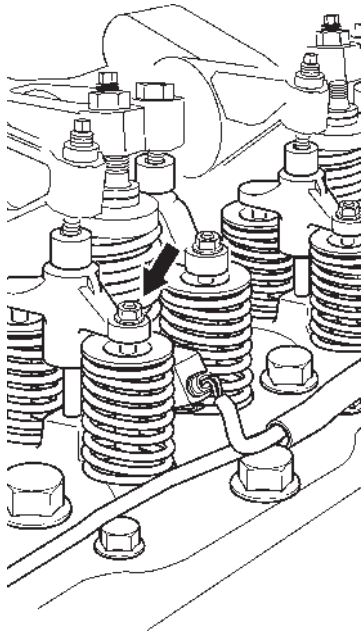

24. Mark and remove the valve calipers.

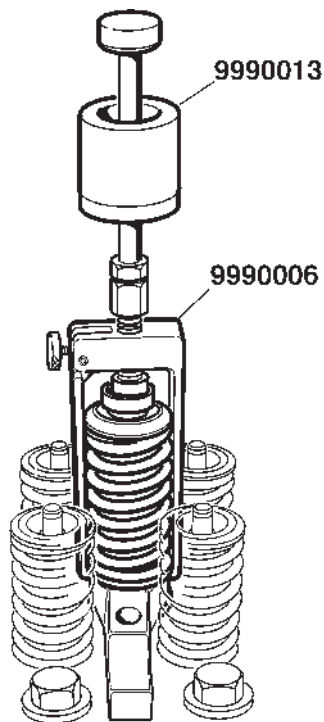

25. Clean around the unit injectors and unscrew the screws for the injector retainers.
Remove the unit injectors, one at a time.

26. Pull up the injector using puller 9990006 and slide hammer 9990013.

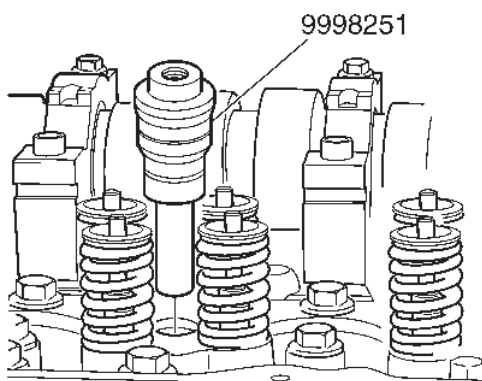

27. Place protection plugs 9998251 in the cylinder head immediately after removal.
Mark the unit injectors and place protective sleeve 9998249 on the injector.

NOTE: Check that the tools are clean.

28. Remove the camshaft cap using tools 9990192 and 9996400.

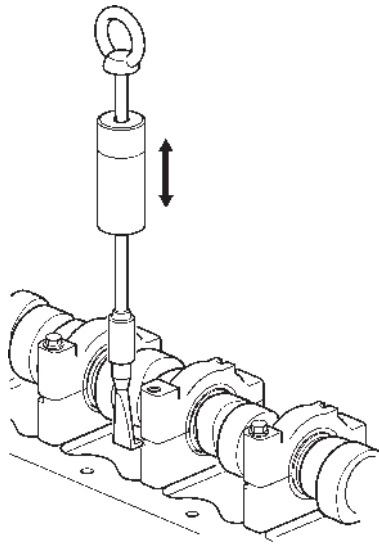

29. Lift the camshaft carefully using tool 9998264.

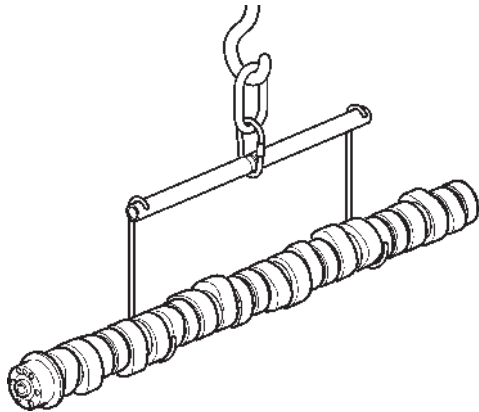

30. Remove bearing blocks by carefully tapping them with a plastic hammer.
Remove the bearing blocks with the lower bearing halves and put them in the right order together with their respective camshaft bearing caps, upper bearing halves and screws.

NOTE: The camshaft bearing blocks are held by guide pins marked 1-7.

31. Turn the engine so that the two screws (1) can be reached through the transmission wheel.

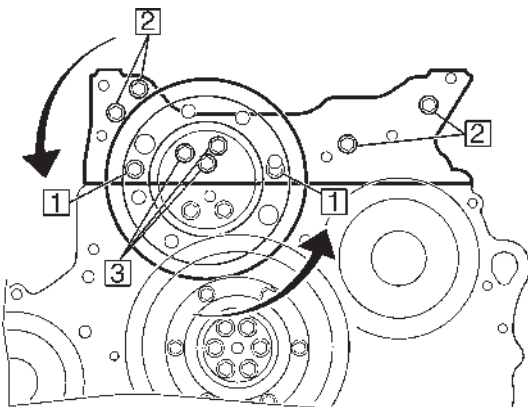

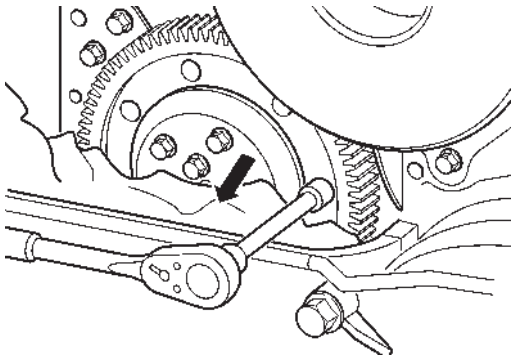

32. Place a rag in front of the drive to prevent screws from falling into the transmission housing. Remove the two screws (1).

NOTE: When the engine is turned, the rag must be removed.

33. Remove the remaining five screws (2). Remove the three upper screws (3) from the transmission wheel hub.

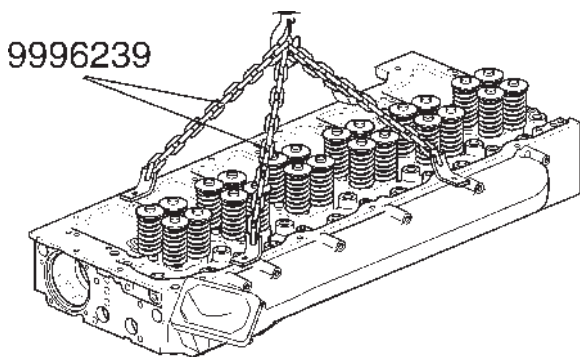

34. Remove the cylinder head screws. Use two lifting chains 9996239 to carefully lift the cylinder head away. (Alternatively, lifting eyes and lifting straps can be used.)

NOTE: Place washers between the cylinder head and lifting chains to protect the cylinder head sealing surface.

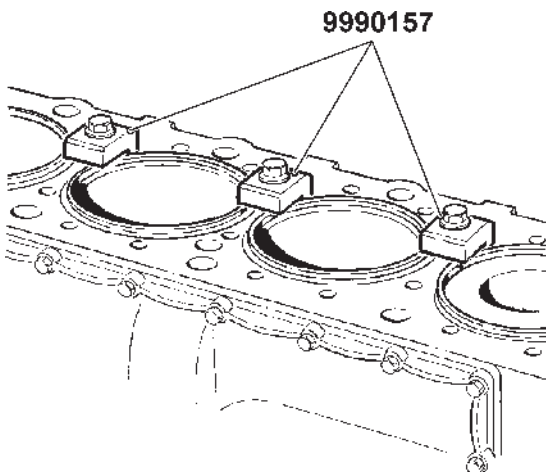

35. Remove the cylinder head gasket and clean contact surface on the cylinder block thoroughly.

NOTE: Secure all cylinder liners using tool 9990157.

36. Remove the starter motor.

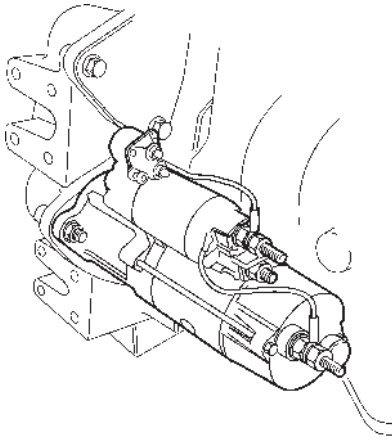

37. Remove the oil filters complete with bracket.

38. Remove the coolant filter with bracket and the connection to the oil cooler casing.

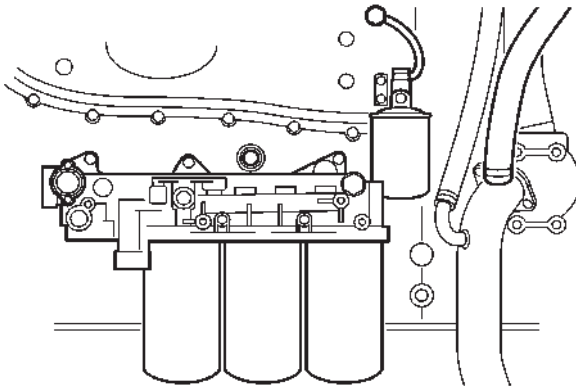

39. Remove the oil cooler casing and the oil cooler. Remove the seals.

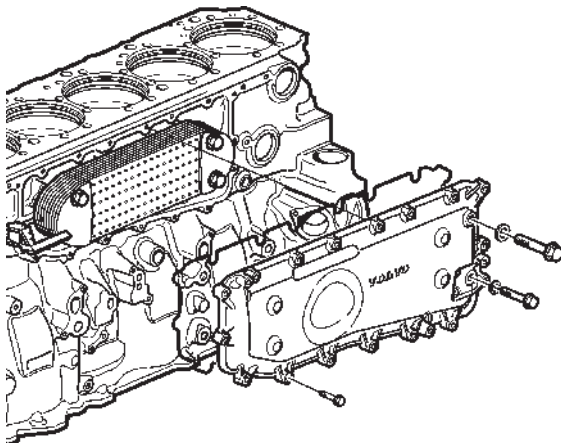

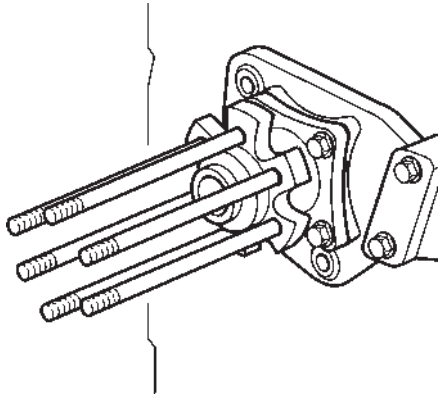

40. Remove the two coolant pipes and the coolant pump.

41. Remove the fan bearing.

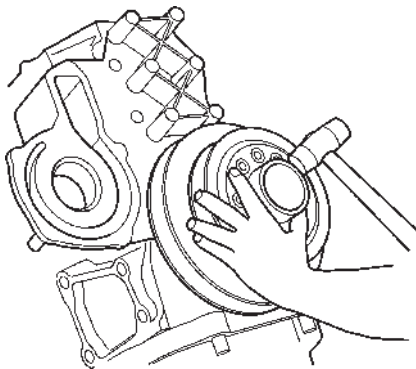

42. Remove the screws for belt pulley/vibration damper. Carefully tap and rock the hub and belt pulley to get them loose.

NOTE: Do not disconnect between belt pulley and vibration damper.

Lift the vibration damper.

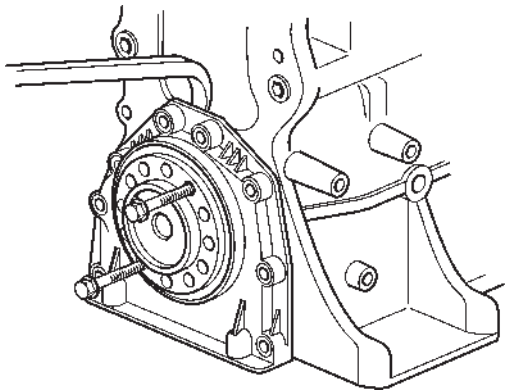

43. Remove the screws and remove the casing for the front crankshaft seal with a crowbar at the reinforcement shown.

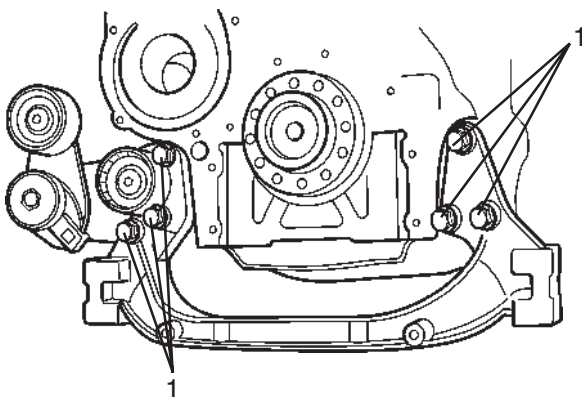

44. Remove the tensioning wheel and the front the engine mounts together with the belt tensioner on the right side of the engine, 6 screws (1).

45. Remove alternator with its brackets together with the belt tensioner and the bracket for the fan bearing on the left side of the engine.

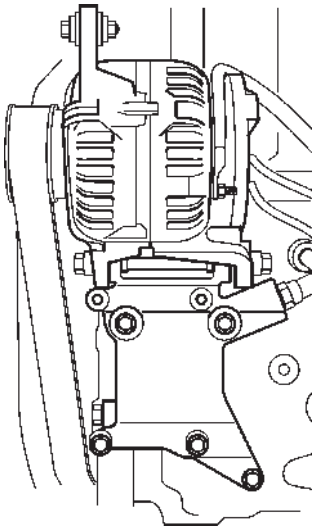

46. Remove engine mounts, oil filler pipe and dipstick.

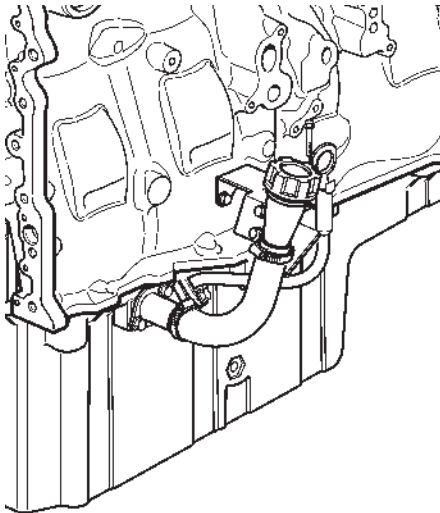

47. Remove fuel pump and servo pump complete.

48. Remove the oil level sensor terminal and remove the oil pan.

49. Remove the oil strainer complete with pipe connections.

50. Remove bracing frame.

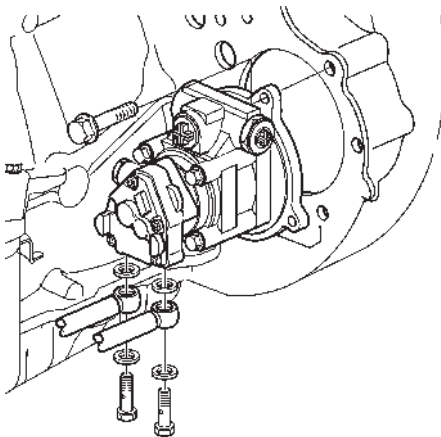

Transmission, removal

51. Remove the flywheel sensor, if not already done.
52. Secure lifting chain 9996239 in the flywheel with two screws.
Remove the screws in the flywheel. Remove the flywheel.

 **WARNING!** Pinching hazard. The flywheel is heavy.

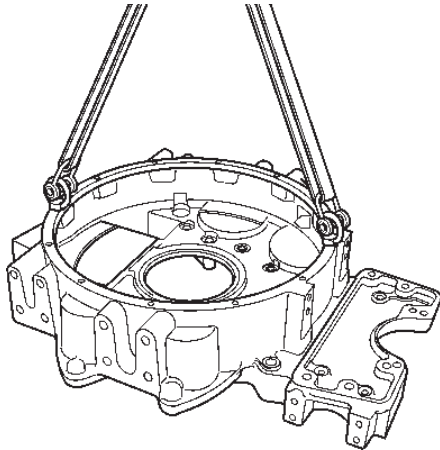
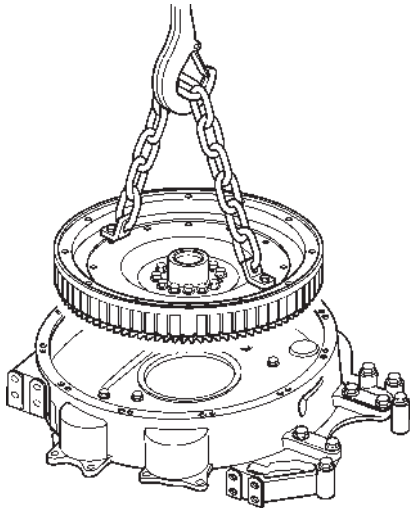

53. Remove the screws in the flywheel casing and remove the flywheel casing using lifting eyes and lifting straps.

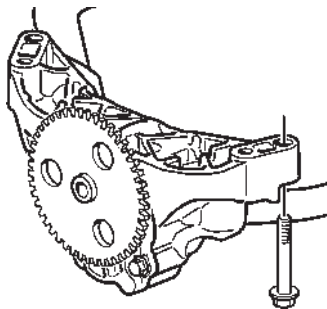

54. Remove the lubricating oil pump together with the drive wheel.

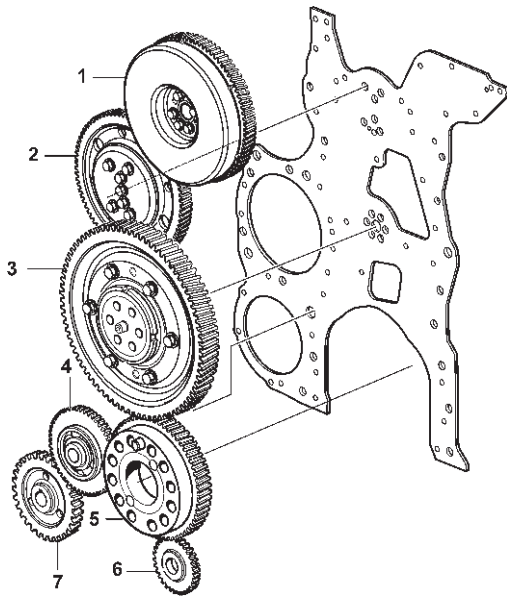

- 1. camshaft drive
- 2. upper intermediate gear
- 3. dual drive
- 4. lower intermediate gear
- 5. crankshaft drive
- 6. oil pump drive wheel
- 7. fuel pump drive wheel/servo pump

55. Remove the lower intermediate gear (4).

56. Remove the two screws on the crankshaft drive (5) and remove the drive using a suitable puller.

NOTE: To protect the puller thread, place a thick washer between the piston ring tool and the crankshaft.

57. Remove the six socket head cap screws in the hub of the double drive (3) and remove it complete.

58. Remove the upper intermediate gear (2).

NOTE: Save the spacer plate behind the drive and write down how it is installed.

59. Remove the transmission plate and clean both sides.

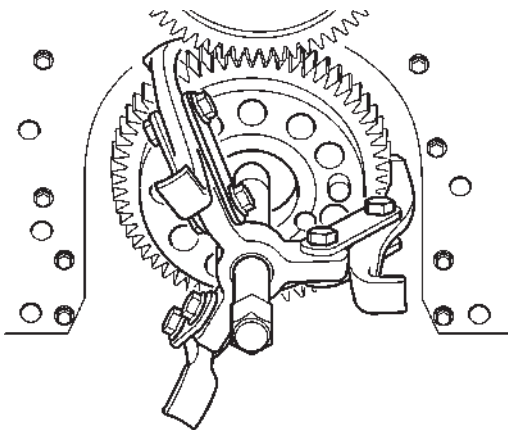

Pistons, removal

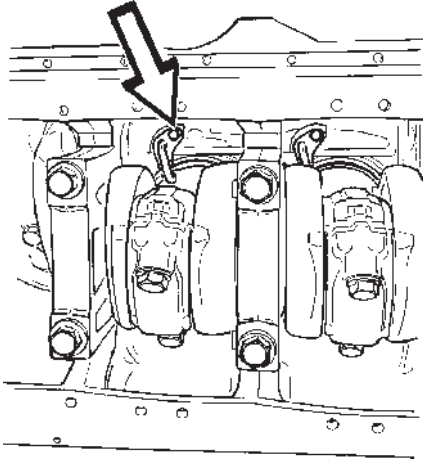

60. Remove the piston cooling nozzle. Turn the engine using tool 9993590 so that all become accessible, two at a time.

⚠ WARNING! It is important to remove the piston cooling nozzles before the pistons are removed. Damaged nozzles can cause extensive engine damage.

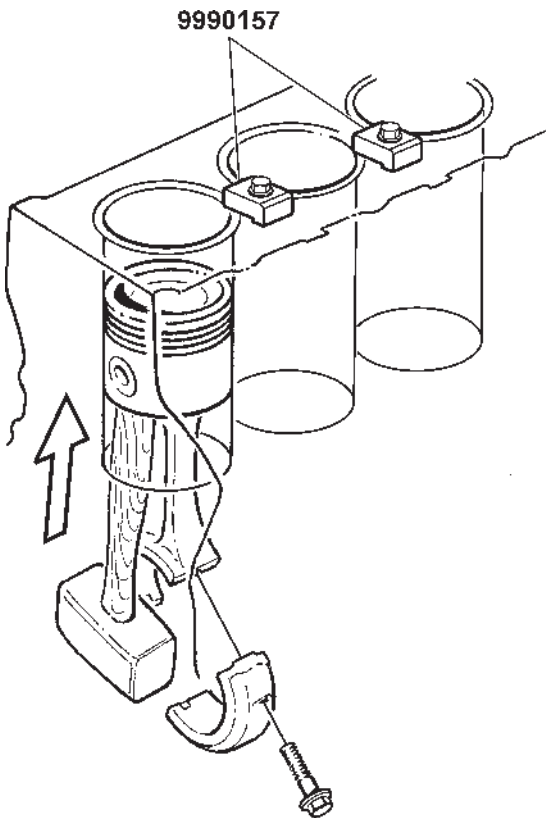

61. Remove main bearing cap and bearing shells, write down the marks.

62. Turn the engine 90° if it is installed in assembly stand 9986485.

63. Press the piston so far out that the piston rings are outside the edge of the cylinder liner. (Use the handle of a hammer or another object made of wood.)

Lift out the piston and the connecting rod.

⚠ IMPORTANT! Reinstall the bearing caps on the connecting rod to avoid damage to the parting surface, since this is very delicate.

64. Remove the circlip from the piston and press out the piston pin. Disassemble connecting rod and piston.

NOTE: Mark the connecting rod and piston, if they are to be installed in the same cylinder at assembly.

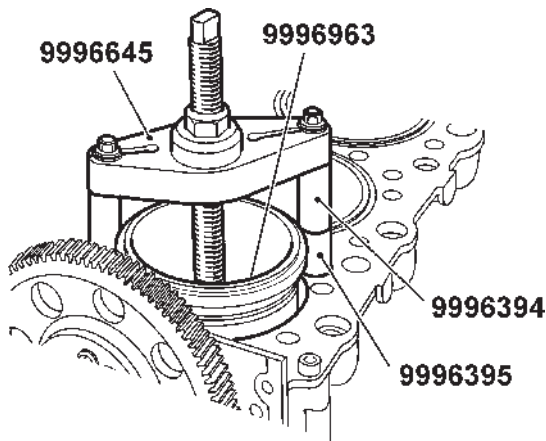

65. Mark the cylinder liner position in the block before it is removed to facilitate correct placement if reinstalled.
66. Install puller plate 9996963 and support 9996394 on the puller 9996645.
67. Move plate down through the cylinder and place it in correct position under the cylinder liner. Pull the impeller off of the pump shaft with the puller. Extend the support legs with 9996395 as needed.
68. Remove the cylinder liner sealing rings.

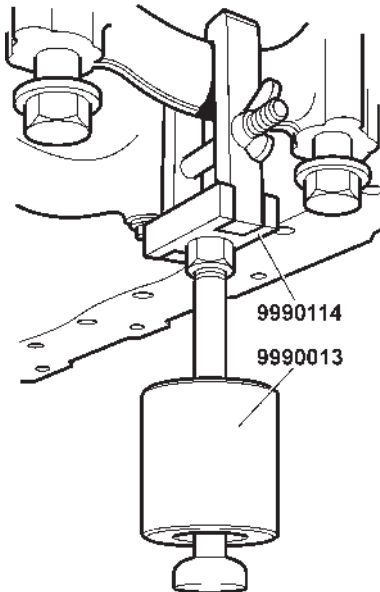

Crankshaft, removal

69. Remove the main bearing caps, if not already done

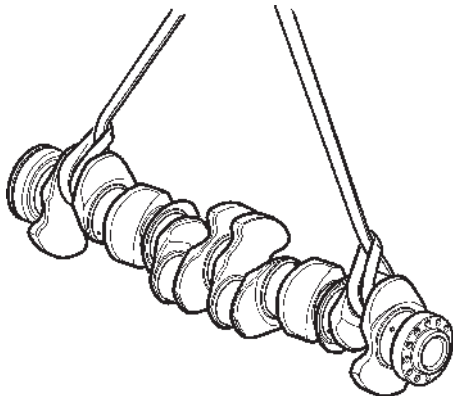

70. Carefully lift out the crankshaft.
NOTE: The crankshaft weighs about 80 kg (180 lbs).
71. Before engine block is washed, plugs, screw and remaining brackets should be removed.
72. Clean contact surfaces on parts to be reinstalled.

Crankshaft, refitting

73. Inspect the crankshaft, see "Crankshaft, inspection"
74. Check the oil channels of crankshaft and its contact surfaces with the bearing shells, cylinder block and caps.
75. Install new main bearing shells.
76. Put the bearing shells in their respective positions in the cylinder block and caps. Make sure that bearing shells or caps are not damaged.

NOTE: Make sure that the upper bearing shells to be installed into the cylinder block are equipped with oil holes.

77. Smear bearing pins and bearing shells with engine oil and carefully lift the crankshaft into position.
78. Install the thrust washers for the center main bearing, the axial bearing. The thrust washers can only be placed in one position.
79. Install the main bearing caps with the lower bearing shells. The bearing caps are asymmetric and can only be installed in one position. The middle bearing cap (at the thrust bearing) incorporates a recess which must be turned to fit over the guide studs.

NOTE: Write down the bearing caps marking, 1-7.

80. Oil the main bearing bolts. Allow excess oil to run off before installation.
Torque as specified in "Technical data."

NOTE: Check that the crankshaft can be turned.

81. Install the front casing at the belt pulley and install a new seal. See "Crankshaft seal, front, replacing."

NOTE: No lubrication. Should be installed completely dry.

Cylinder liner, fitting

82. Inspect cylinder liner and pistons, see "Cylinder liner and pistons, inspection"

83. Lubricate the sealing rings, using the lubricant supplied with the lining kit, and install them on the cylinder liner.

NOTE: The purple seal ring belongs in the lowest groove.

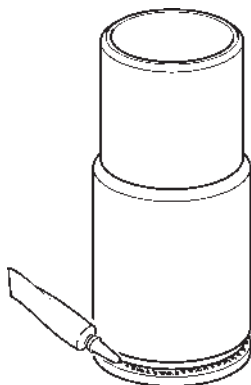
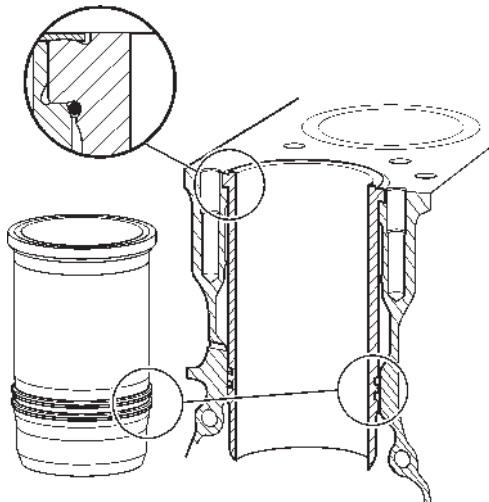

without adjustment shims

84. When the cylinder liner is installed without shims, an even 0.8 mm (0.0315") bead of sealing compound (1161231) should be applied to the underside of the cylinder liner collar.

NOTE: Do not put the seal around the entire liner. Leave a 2 mm (0.0787") opening.

If the liner is fitted with adjustment shims, the sealant compound bead should be placed on the cylinder block liner seat.

NOTE: Sealing compound must not be used between adjusting shims and the cylinder liner collar.

NOTE: The liner must be positioned within 20 minutes after application of sealing compound.

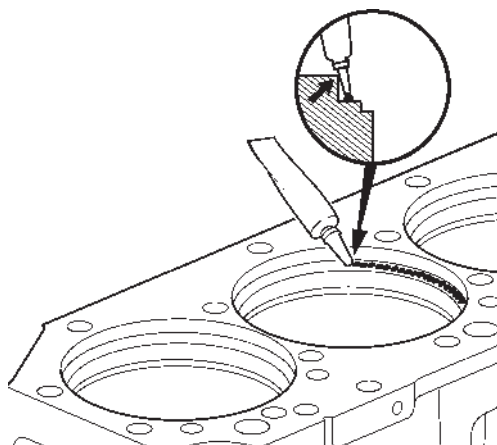

with adjustment shims

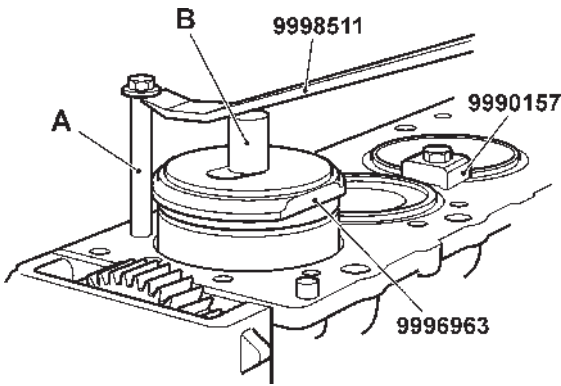

85. Secure one of the cylinder head screws (**A**). Place tool 9996963 above the cylinder liner together with appropriate spacer (**B**). Press the liner down with crowbar 9998511 and secure it using tool 9990157.

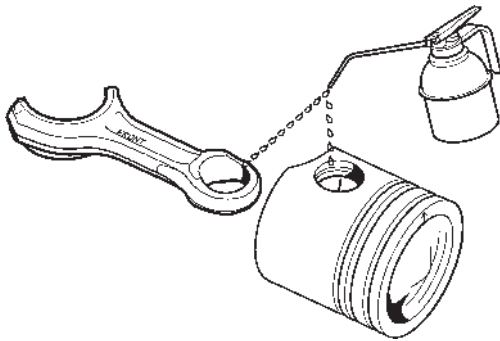

Piston, pre-fitting

86. Install one of the circlips on the new piston.
87. Oil the piston pin, the piston bearing seat and connecting rod bushing with engine oil.

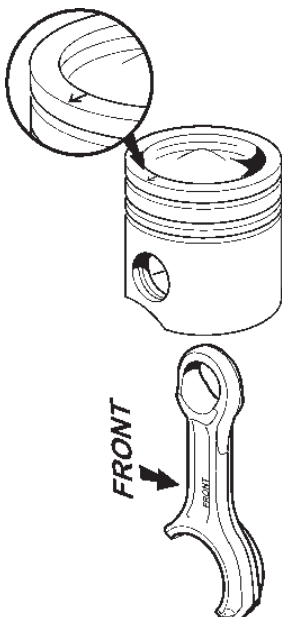

88. Fit the connecting rod with the arrow on the piston and the word "Front"- on the connecting rod pointing in the same direction.

Press in the piston pin.

NOTE: The piston pin The piston pin should enter easily, it must **not** be knocked in.

89. Install the other circlip.
90. Check that the piston pin does not move stiffly in the connecting rod bushing but that the piston moves easily.

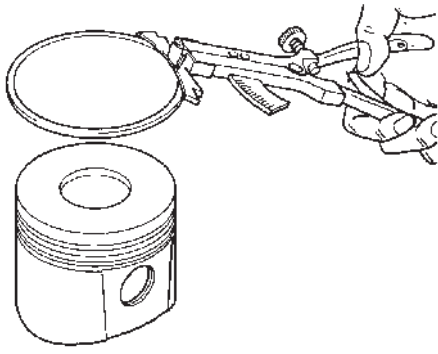

⚠ IMPORTANT! Always use piston ring pliers during installation/removal of the piston rings. The oil scraper rings, especially, are brittle and are easily damaged.

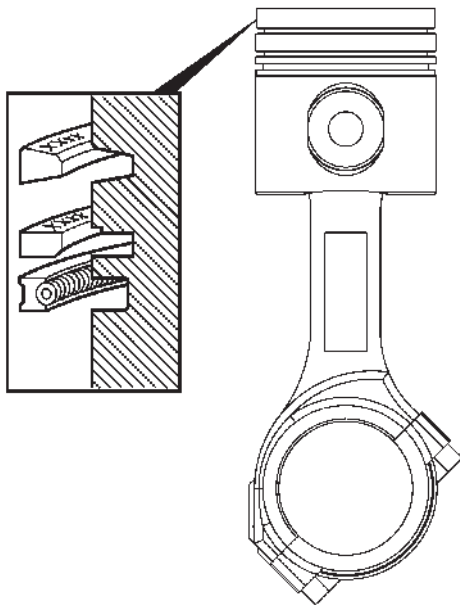

NOTE: The two upper piston rings are marked with letters or point marks. The mark shall be turned up.

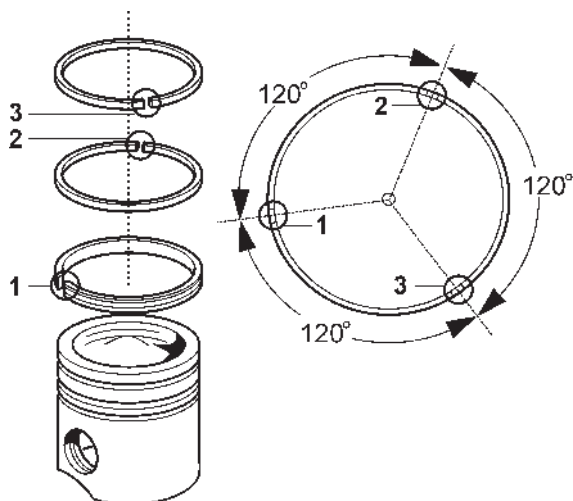

91. Place the piston ring gaps offset about 120° offset on the piston. However, the piston ring openings may not end up straight above the piston pin.

NOTE: New cylinder lining kits are delivered complete with pistons and piston rings.

92. Install the bearing shells in the connecting rod.

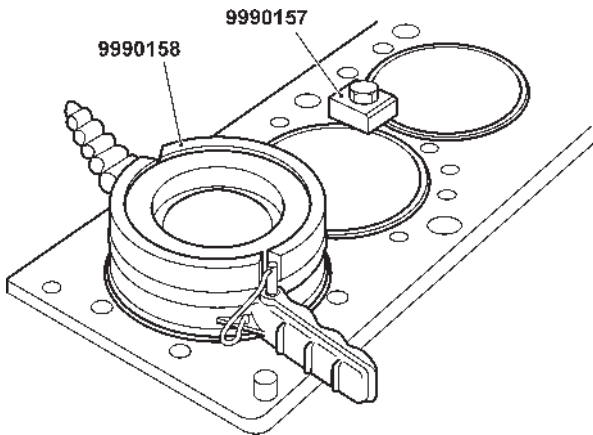

Pistons, fitting

93. Oil the cylinder liner, the bearing shells and the crank bearing pins.
94. Remove press tool 9990157 temporarily while installing the piston.
95. Use tool 9990158 and guide the piston with piston rings down into the cylinder. Check that the connecting rod does not damage the crankshaft bearing pin.

NOTE: Be careful. The oil scraper rings are brittle and are easily damaged.

NOTE: The piston ring compressor may not open when the piston has been placed in the tool. The piston rings can be damaged. Press out the piston first, before opening the tool.

96. Reinstall press tool 9990157. All cylinder liners must be locked with the press tool in order to prevent movement between cylinder liner and engine block when the engine is cranked.
97. Install the bearing caps with their bearing halves. Torque as specified in "Technical data."

Piston cooling nozzle, fitting

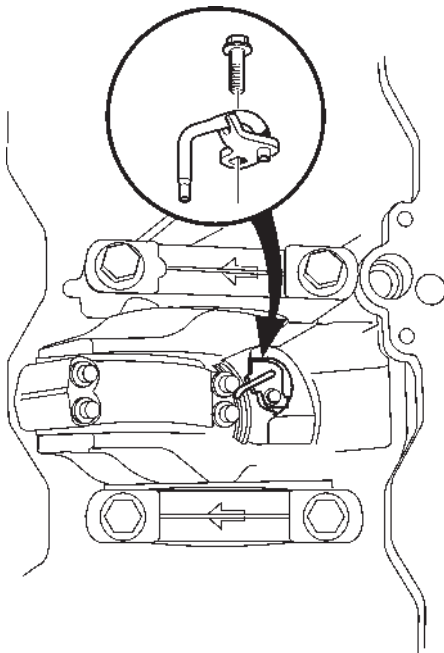

98. Blow the piston cooling nozzle clean and check for damage and that the O-ring is flawless.
- ⚠ WARNING!** Faulty piston cooling results in piston seizure. If you suspect that the piston cooling nozzle may be damaged or deformed, it should be replaced (applies to new nozzles as well).

99. Install piston cooling nozzle.
- ⚠ IMPORTANT!** Check that the nozzle is placed correctly in the hole in the cylinder block and is directed towards the recess in the piston and that the retaining plate lies flat against the block. If the piston cooling nozzle is not correctly installed, the engine will immediately break down when loaded.

100. Torque as specified in "Technical data."

NOTE: The piston cooling nozzle retaining screw has a friction coating and may only be used once.

101. Install bracing frame and torque as specified in "Technical data."

Transmission, fitting

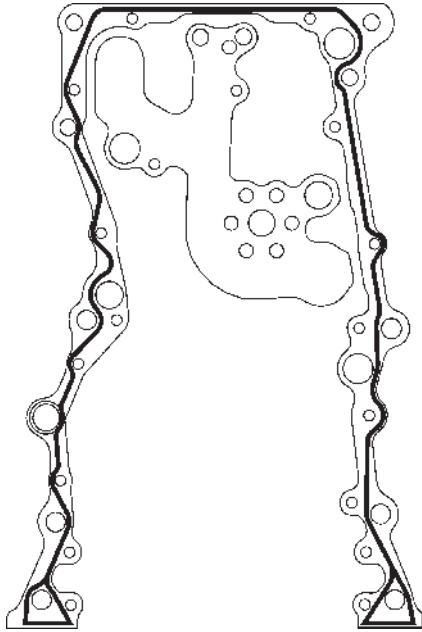

102. Apply a 2 mm (0.080") thick string of sealant on the engine block as shown.

103. Install the transmission plate. Use new screws that are pre-treated with locking compound. Torque as specified in "Technical data."

NOTE: Torque within 20 minutes after sealant has been applied.

104. **NOTE:** Lubricate the inside of the gears before you place them.

Oil the spacer plate and place it together with the upper intermediate gear (2). Torque gently, max 10 Nm.

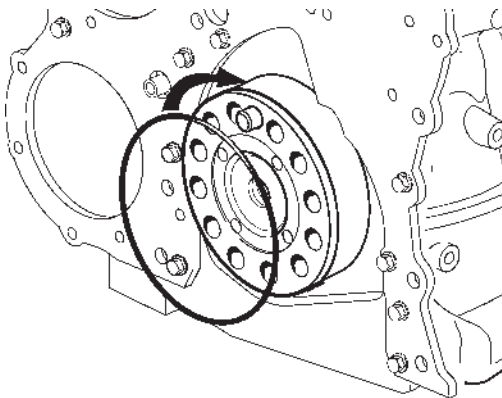

105. Install a new o-ring on the crankshaft.

106. Fit the crankshaft drive (5) and torque the screws as specified in "Technical data."

NOTE: Make sure that the mating surfaces on crankshaft and drive are clean and flawless.

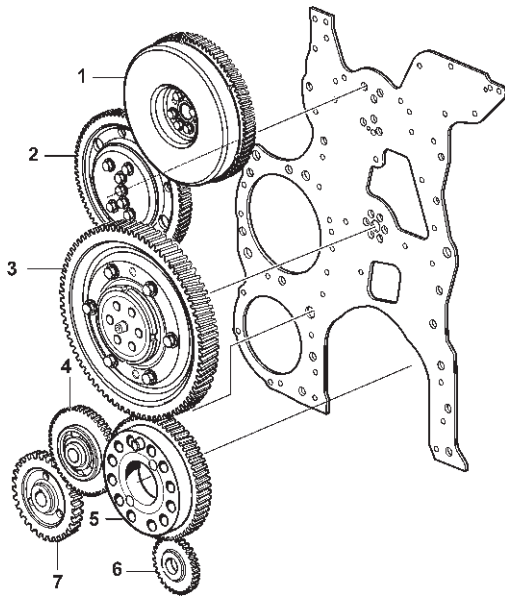

1. camshaft drive
2. upper intermediate gear
3. dual drive
4. lower intermediate gear
5. crankshaft drive
6. oil pump drive wheel
7. fuel pump drive wheel/servo pump

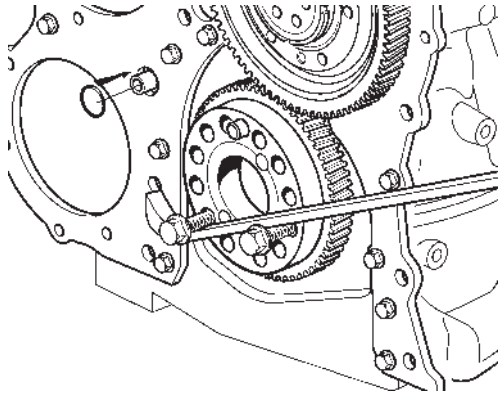

107. Place two screws in the crankshaft drive so you can attach a crowbar and thus be able to turn the crankshaft as needed.

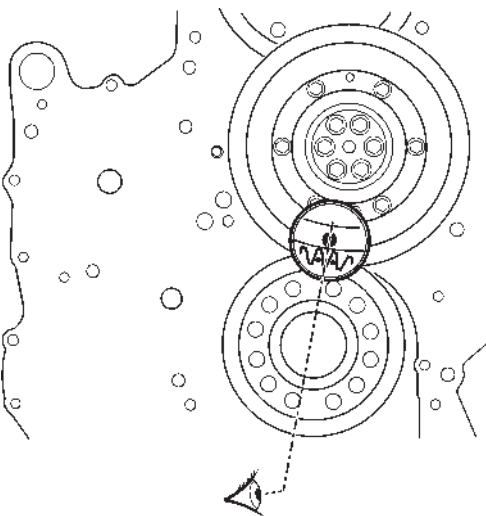

108. Install the double drive kit (3) with the hole marking between the two hole markings on the crankshaft drive.
NOTE:The double drive inner and outer gears, respectively, have different gear pitch. For the camshaft to be set correctly, the markings must be correct.

Torque the screws as specified in "Technical data."

109. Install the bottom intermediate gear (4) with a new O-ring.

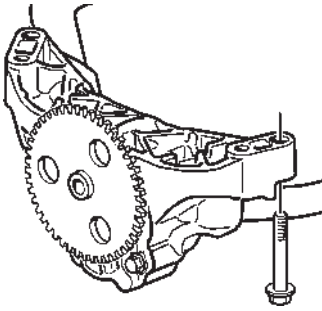

110. Install the lubricating oil pump.

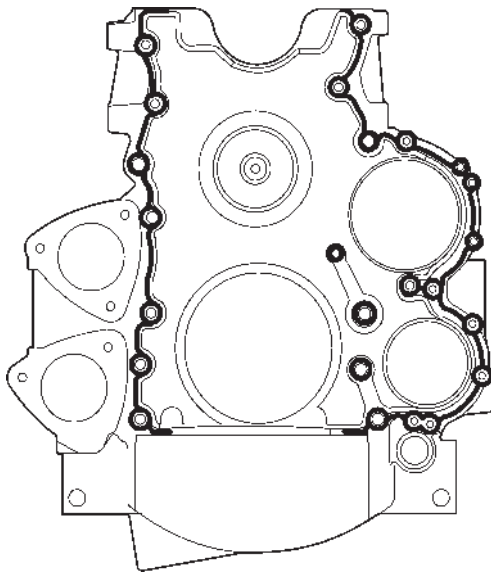

111. Apply new sealing compound to the flywheel casing, towards the engine block.

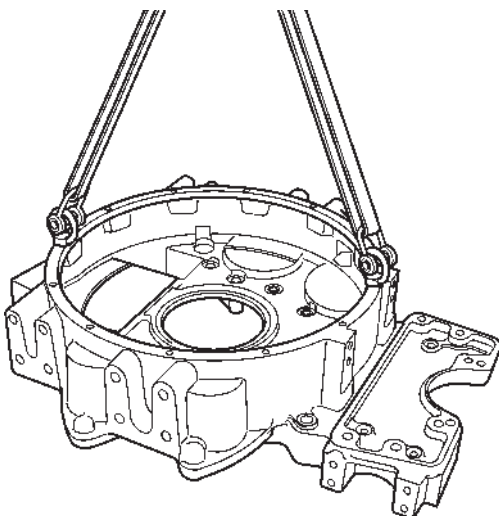

112. Remove the old crankshaft seal.
Install the flywheel casing. Check that the casing is aligned with the engine block plane.
Torque as specified in "Technical data."
Install the new crankshaft seal, see "Crankshaft seal, rear, replacing."

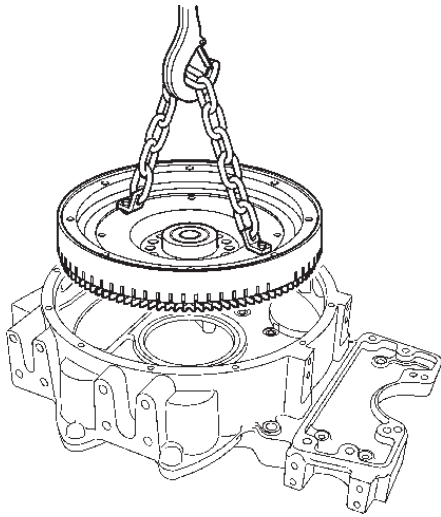

113. Install the flywheel and torque as specified in "Technical data." See also "Flywheel, checking for warp."

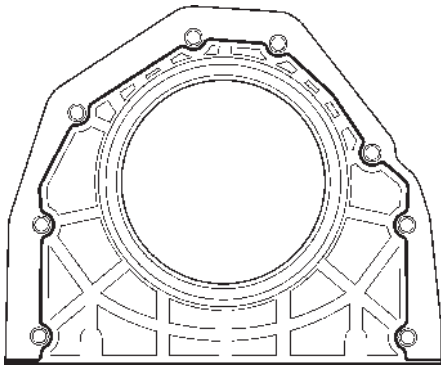

114. Remove the old crankshaft seal on the front the casing. See "Crankshaft seal, front, replacing."

Apply sealing compound to the front casing. Install the casing and make sure that the bottom edge of the casing is lined up with the bottom edge of the engine block.

Install a new crankshaft seal (if not already done).

NOTE: No lubrication. The seal should be installed completely dry.

115. Fit vibration damper and the belt pulley.

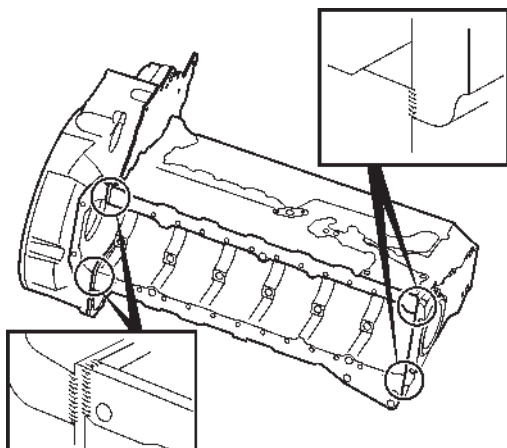

116. Install the oil suction strainer with pipe.

117. Cut away any remaining sealing compound and put on new in the parting planes on the front casing, flywheel casing and engine block, respectively.

118. Fit the oil pan.

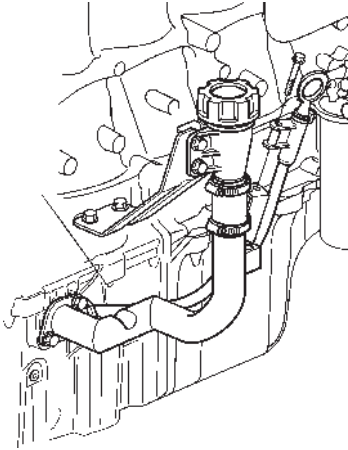

119. Install oil filler pipe and dipstick with new o-rings.

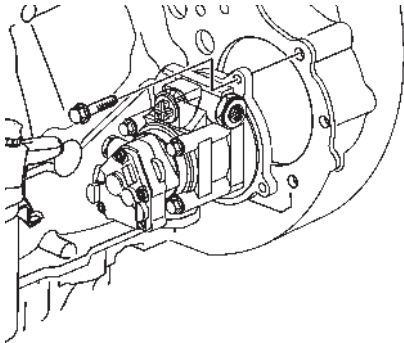

120. Install fuel feed pump/servo pump.

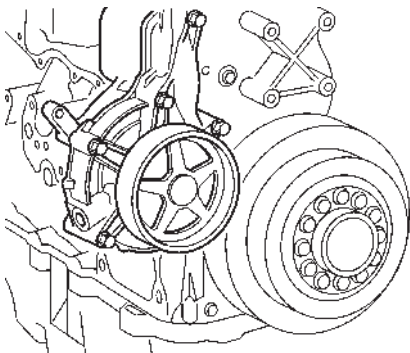

121. Fit the coolant pump.

122. Fit the front engine mounts together with the belt tensioner and the tensioning wheel on the right side of the engine.

123. Install the alternator with brackets and the belt tensioner and the fan bearing brackets on the left side of the engine.

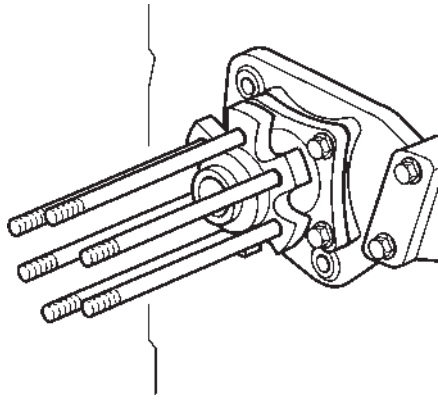

124. Install the fan bearing.

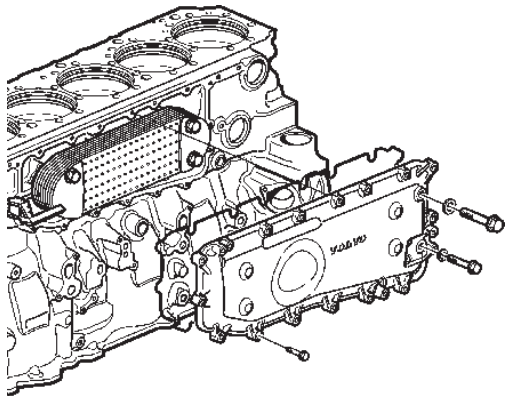

125. Fit new sealing rings in the block and the rubber seals on the sides of the radiator.

Install the oil cooler and torque as specified in "Technical data." Check that the side seals are placed correctly in the block.

126. Install the oil cooler casing with a new o-ring and torque as specified in "Technical data."

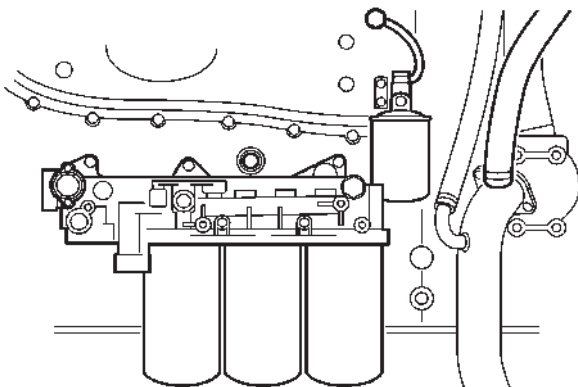

127. Install coolant filter with bracket and the connection to the oil cooler cover.

128. Install the oil filter bracket with new gasket and new oil filters.

129. Fit the starter motor.

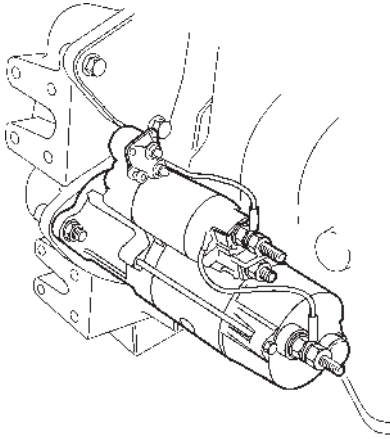

130. Install the coolant pipes with new o-rings.

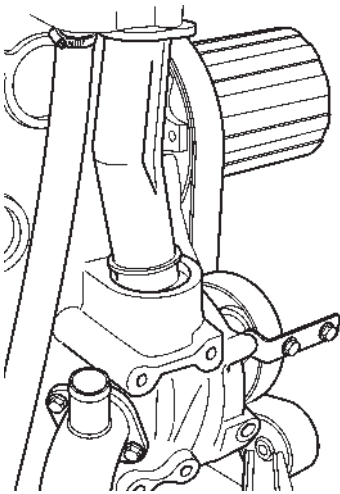

Cylinder head, refitting

131. Clean the cylinder head thoroughly inside and out before installing.

NOTE: Dirt particles can destroy the unit injectors.

132. Clean the unit injector copper sleeves. See "Reconditioning/Replacing: Copper sleeve for unit injector, replacing."

Install protection plugs immediately after cleaning.

133. Remove press tool 9990157 which holds the cylinder liners in place.

134. Carefully clean the cylinder head and the engine block sealing surfaces, cut away excess sealant.

NOTE: Do not pull away dry sealant.

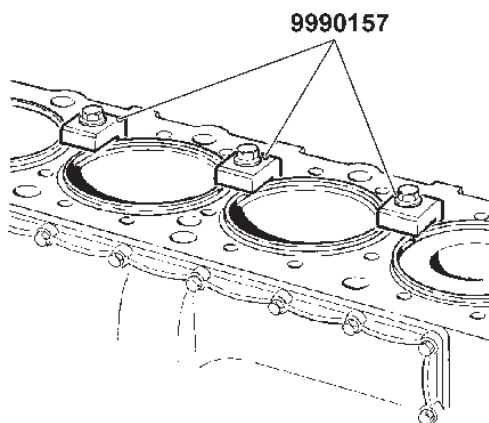

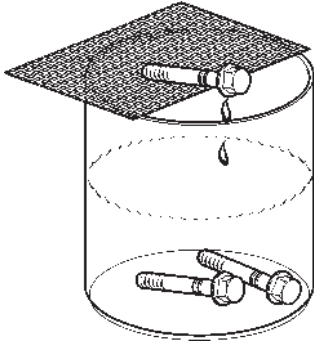

135. Dip the cylinder head bolts completely into a rust-proofing agent.
Then place the screws on a net to remove excess.

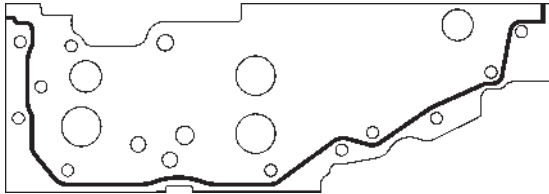

136. Apply a 2 mm (0.080") thick string of sealant on the back side of the engine block.

NOTE: The cylinder head screws must be torqued within 20 minutes after sealant application.

137. Fit a new cylinder head gasket.

NOTE: Convex embossings prevent damage to the rubber seals.

NOTE: Check that the coolant pipe is in place.

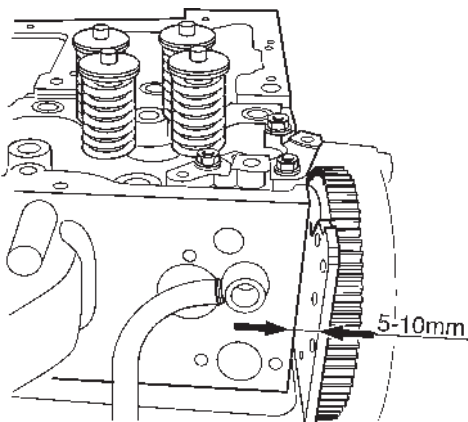

138. Lower the cylinder head until it rests on the cylinder head gasket.

Maintain a distance to the transmission plate of 5-10 mm (0.197 - 0.394"). Locating pins ensure that the cylinder head will be aligned with the engine block.

139. Slide the cylinder head against the transmission plate.

140. Place a rag in front of the drive to prevent screws from falling into the transmission housing.

NOTE: The rag must be removed when the engine is to be turned over.

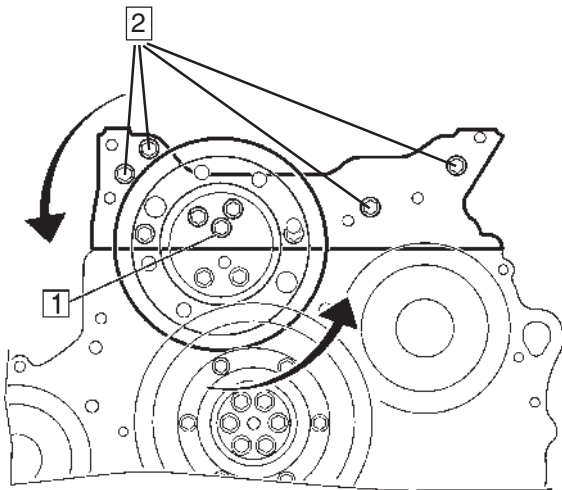

141. Place a screw in the upper intermediate gear hub (1) into the cylinder head, so you can pull the cylinder head towards the transmission plate.
Screw in five M8 screws in the transmission plate (2).

142. Torque the screws (1) and (2) as specified in "Technical data."

Unscrew all screws (1) and (2) about one turn.

NOTE: The cylinder head is now in the correct position to be secured and must not be moved. If the cylinder head is moved, the screws must again be torqued and loosened as above.

143. Install the cylinder head screws and torque as specified in "Technical data." Use torque amplifier for angle tightening.

144. Torque the five M8 screws in the transmission plate (2) as specified in "Technical data."

145. Turn the engine so that the two M8 screws (1) can be installed through the upper intermediate gear. Torque as specified in "Technical data."

146. Fit the remaining two M10 screws (3) into the upper intermediate gear, without tightening.

147. Tighten the coolant pipe in the cylinder head.

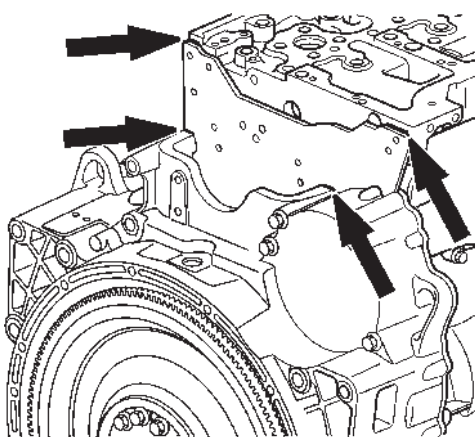

148. Clean the surface of sealant as shown.

NOTE: Cut away the sealant.

Camshaft, refitting

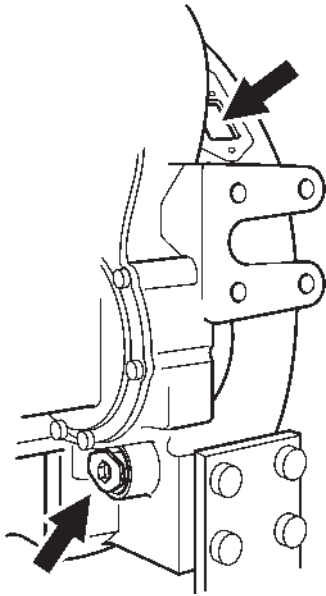

149. Check the camshaft for wear. See “Camshaft, checking for wear.”
150. Clean surfaces on bearing blocks and the cylinder head.
151. Install the camshaft bearing blocks as marked on the cylinder head, make sure that they rest on the cylinder head no. 7 at the transmission.
152. Place the bearing shells in the bearing blocks and lubricate the bearing shells with engine oil.
153. Turn the engine with the turning tool so that the flywheel is set exactly to zero, per the marking on the flywheel casing.

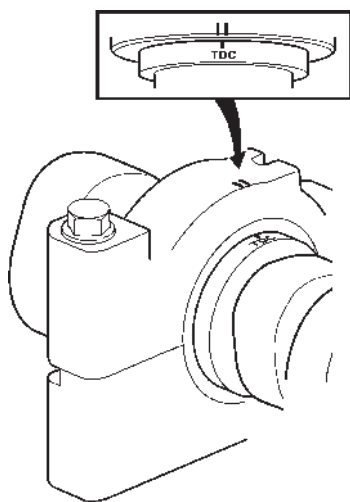

154. Carefully lift the camshaft in place. Make sure that the hole for the guide pin on the camshaft drive ends up straight up. The camshaft marking TDC should be centered between the markings on the no 7 bearing block.

 **WARNING!** Camshaft ridges are sharp.

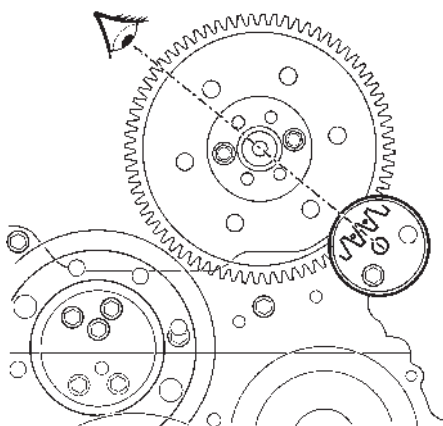

155. Fit the camshaft drive without the vibration damper, use nuts for spacers. Place the drive so that the reference hole in the transmission plate lies between the drive markings. As needed, remove the screws on the upper intermediate gear. Tighten two screws temporarily with low torque, max 10 Nm (7.4 lbf ft).

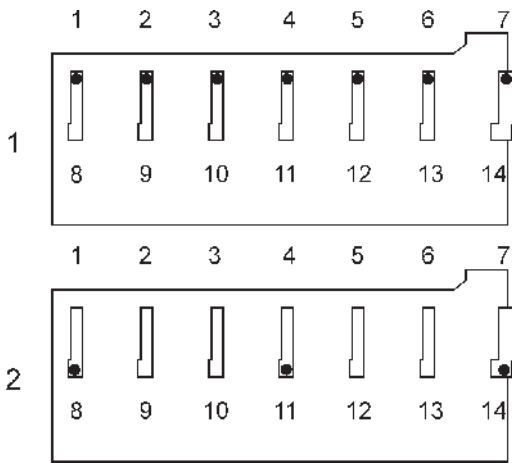

156. Clean surfaces on the bearing caps and oil the bearing shells.
Install the bearing caps on the respective bearing block.

NOTE: Use a suitable spacer on the rocker arm side.

Torque screws 1-7 per step 1 in "Technical data."

Torque screws 8, 11, 14 (with spacers) per step 2 in "Technical data."

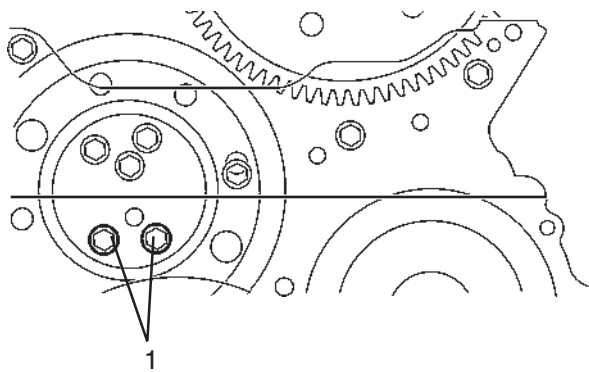

Gear backlash, adjusting

157. Remove the screws (1) in the upper intermediate gear. Check that the upper screws are not tightened.

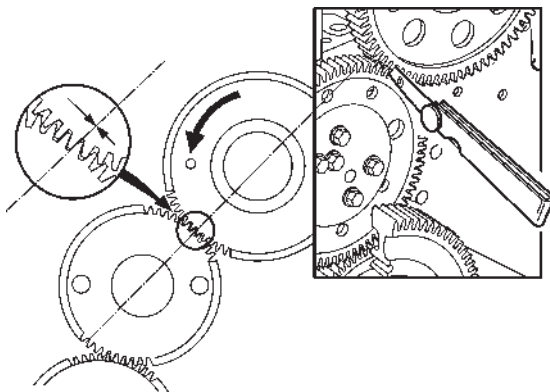

158. Place a 0.1 mm (0.0040") feeler gauge the pressure side. Turn the camshaft drive against the feeler gauge.

Torque the upper intermediate gear per step 1 in "Technical data."

Remove the feeler gauge.

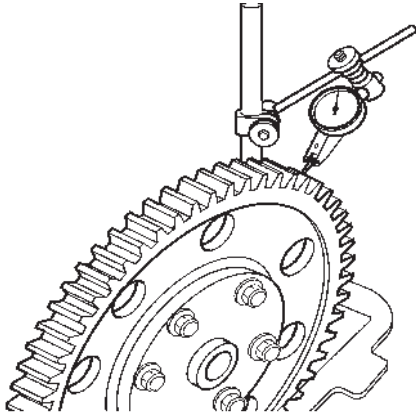

159. Check the clearance as follows:
Fix the adjustment wheel.
Place a dial indicator on the camshaft drive, as shown.
Turn the drive back and forth and compare the result against the specification for gear backlash in "Technical data."
160. If gear backlash is correct; torque the screws on the upper intermediate gear (1) per step 2 in "Technical data."
161. Place the vibration damper into position and torque as specified in "Technical data."

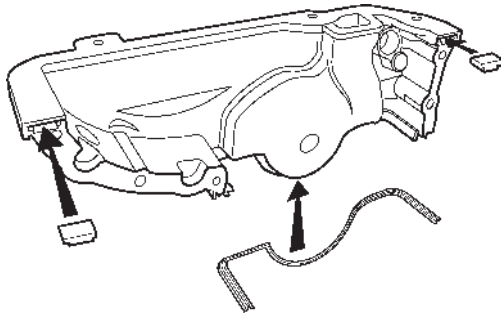

162. Apply a 2 mm (0.080") thick string of sealant to the upper transmission gear casing contact surface, as shown.
163. Fit the rubber seals and install the upper transmission gear casing.

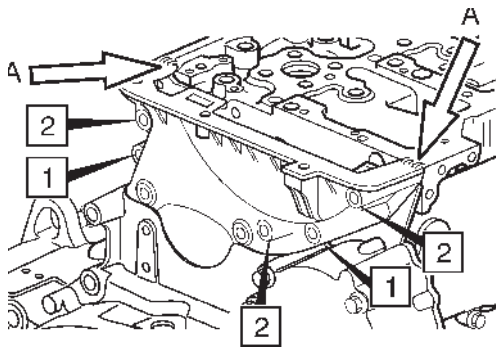

164. Only fit the screws (1) and tighten by hand. (The holes are oblong so that you can press the casing down towards the rubber seal.)

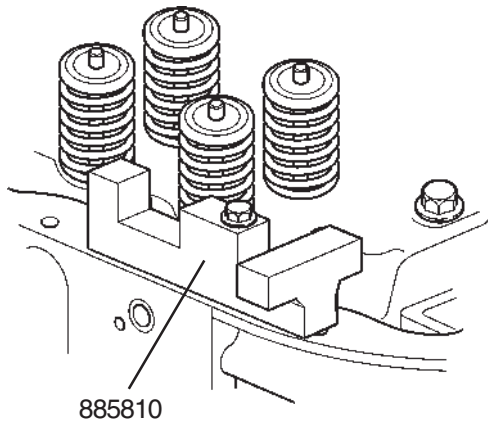

165. Press the casing down with the tools 885810 and 9998601 so that the cylinder head and the upper transmission gear casing sealing surfaces are aligned.

Refit the other bolts (2).

Torque as specified in "Technical data."

NOTE: The transmission gear casing must be installed and torqued within 20 minutes after sealant application.

166. Install camshaft sensor and adjust per "Camshaft sensor distance, checking."

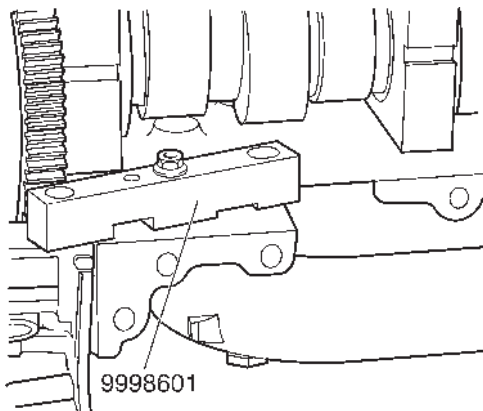

Unit injector, refitting

NOTE: Install one injector at a time.

167. Remove protection plugs 9998251 with adapter 9990156 and slide hammer 9996400.

168. Fit new seal rings to the unit injectors. Lubricate the rings with diesel oil.

Install injectors and retainers. Center the injector so it does not touch the valve springs.

Torque as specified in "Technical data."

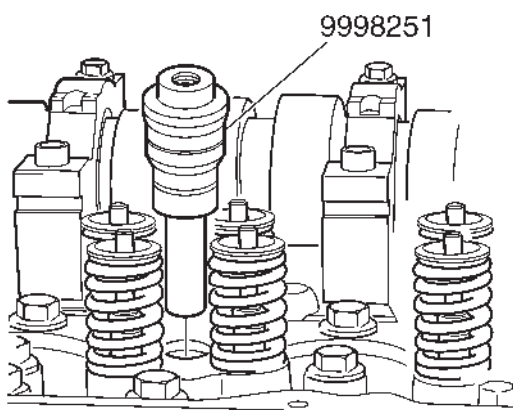

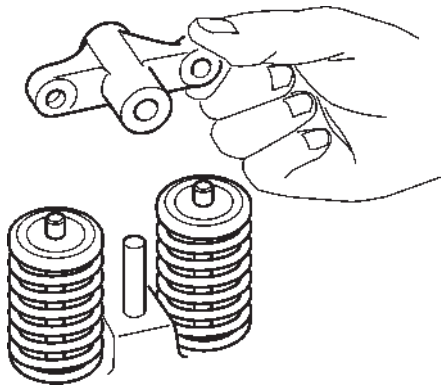

169. Reinstall the valve calipers in their original positions.

NOTE: Make sure that the yoke is directly above the valve stem.

170. Lubricate valve caliper and camshaft.

171. Remove the temporary screws with spacers on the camshaft cap.

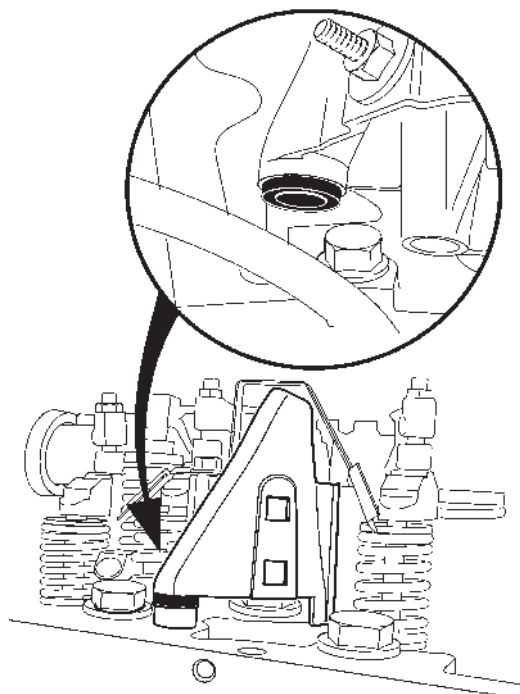

172. Fit the rocker bridge with lifting tool.

Make sure that the guide pins fit into the rocker arm shaft.

Torque the screws alternately along the rocker arm shaft as specified in "Technical data."

173. Slip on new O-rings over the rocker bridge lubricating oil supply pipe. Place the pipe in the middle piece and install the middle piece with its pipe. Check that the O-rings on the pipe and ring under the middle piece are positioned correctly. Fit the cable holder.

Adjustment markings

The camshaft has markings (1-6 for the respective cylinders) for adjusting inlet and outlet valves and the unit injectors.

NOTE: It is important that the line on the camshaft is right between the marks on thrust bearing cap when making the adjustment.

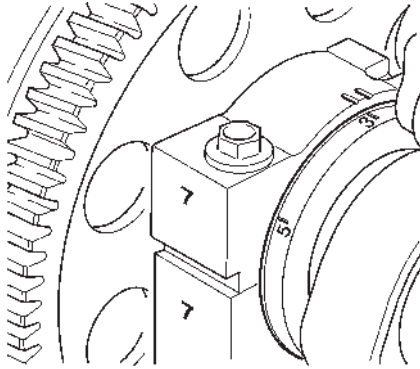

Valves and injectors, adjusting

Adjust valves and injectors for the respective cylinders at the same time.

174. Turn the engine to the next camshaft marking.

175. Screw the adjustment screw down so it rests against the valve stem and thereafter an additional sixth turn (60°).

Torque the lock nut as specified in "Technical data."

NOTE: When the adjustment screw is turned down, the yoke must simultaneously be pressed down so it touches the valve stem. It is very important that the pressure is brought to bear as close to the adjustment screw as possible, see illustration.

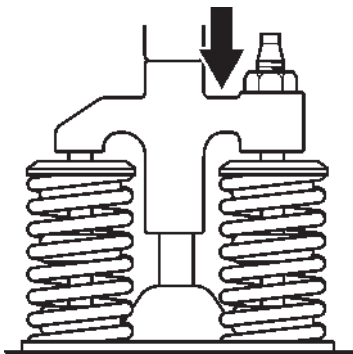

176. Adjust the valve clearance between rocker arm and valve caliper as specified in "Technical data."

Torque the lock nut as specified in "Technical data."

Check the valve clearance. Mark the rocker arm when the valve has been adjusted.

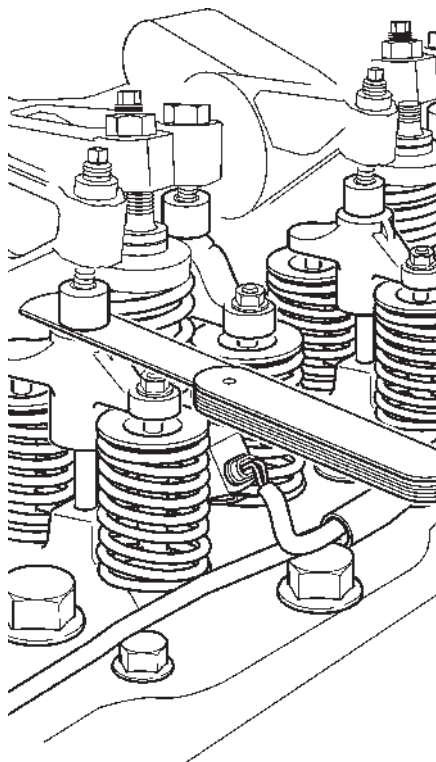

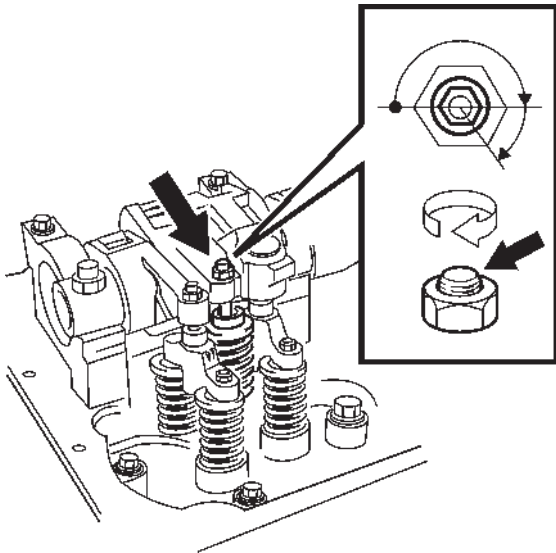

177. Adjust the unit injector rocker arm to zero clearance.
Tighten the adjustment screw nut another 180 to 240 degrees.
Torque the adjustment screw nut as specified in "Technical data."
178. Adjust remaining valves and unit injector per the above.

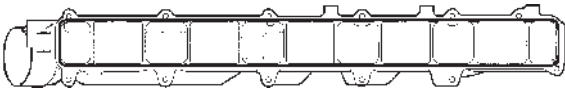

179. Apply a 2 mm (0.080") thick bead of sealant (1161231-4) to the intake manifold.
Install the intake manifold and torque as specified in "Technical data."

NOTE: The intake manifold must be installed within 20 minutes after sealant application.

180. Pull the cable harness to the unit injectors through the cylinder head and connect.
181. Fit the rear lifting eye.
182. Install sensors for flywheel, camshaft and oil pressure and cables to the starter motor.

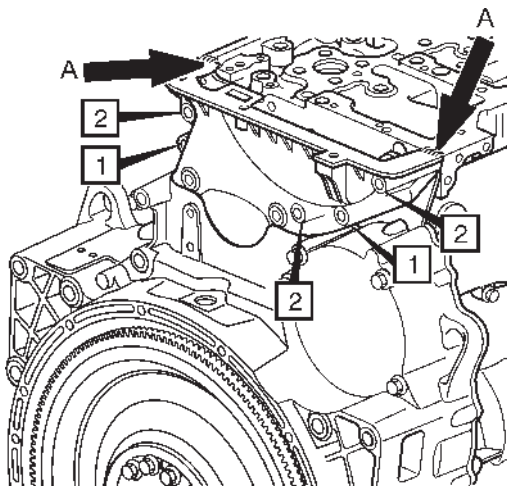

183. Connect the fuel lines to the cylinder head and torque as specified in "Technical data."
184. Apply a 2 mm (0.080") thick bead of sealant to parting plane (A) between the transmission gear casing and the cylinder head.
185. Install the valve cover. Torque the screws as specified in "Technical data."

NOTE: The valve cover must be installed within 20 minutes after sealant application.

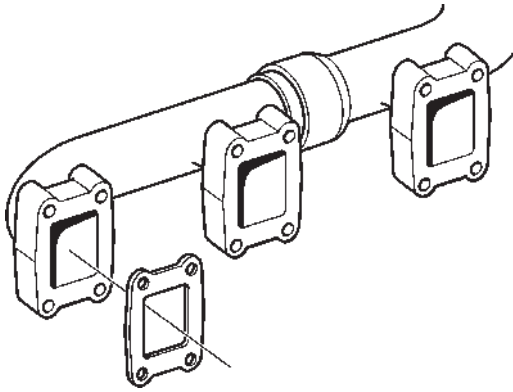

186. Place the gaskets on the exhaust manifold. Turn the gasket so that the side with the text “Manifold side” is facing the exhaust manifold. “Thread in” the screws in the gaskets so that they are held in place during installation of the exhaust manifold. Install the exhaust manifold and torque as specified in “Technical data.”

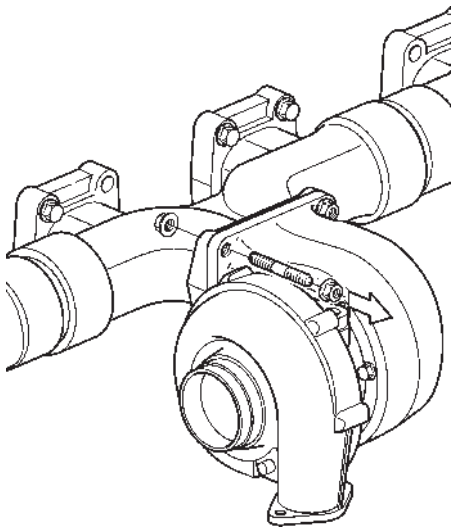

187. Install the turbo without tightening.
188. Fit the return oil pipe. Check that the old seal is not left and that the new one ends up in correct position. Install pressure pipe between the oil filter bracket and the turbo. Torque as specified in “Technical data.”

189. Install the heat shields.
190. Fit the thermostat housing and torque alternately. Install the front lifting eye.
191. Fit the new coolant pipe sealing rings and torque alternately.
192. Remove fixture and replace the parts that were removed.
193. Install drive belts and the fan.
194. Install brackets for radiator fan safety cover or screen. Install the shields.

195. Install safety cover above alternator
196. Install the pipe between charge air cooler and inlet pipe.
197. Install the crankcase ventilation pipe and any extra oil separator.
198. Place a new insert in the air filter housing and install it with brackets and the pipe between the air filter housing and the turbo.
199. Install the pipe between the turbo and the charge air cooler.
200. Install muffler with brackets. Connect the exhaust pipe to the turbo.
201. Install heat shield above the turbo, if any.
202. Install any protective plate on the right side of the engine. Install the hoses to expansion tank and radiator.
203. Replace oil filter. Add engine oil, see "Engine oil and oil filters, replacing."
204. Replace coolant filter. Add coolant, See "Cooling system, filling."
205. Replace fuel filter. Bleed the fuel system, see "Fuel system, bleeding."
206. Start the engine and let it run until it reaches normal operating temperature. Let it idle another 5-10 minutes. When the idle is even, the cylinder balancing system has set the correct amount of fuel for the unit injectors.

NOTE: Do not connect any power consuming device (such as power outlet) while cylinder balancing is underway.

Check that no leakage occurs.

Reconditioning / replacing components

Group 21: Engine body

Cylinder liner and pistons, inspection

Clean cylinder liner and pistons carefully before inspection and measurement.

NOTE: Cylinder liner and pistons are classified together. This means that pistons and liners must not be mixed.

The piston and cylinder liner sets are only available from stock as a single, complete unit.

Cylinder liner

You can measure the cylinder liner collar wear with the liner installed in the cylinder block.

NOTE: In order to thoroughly check for cracks, the cylinder liner must be removed from the cylinder block.

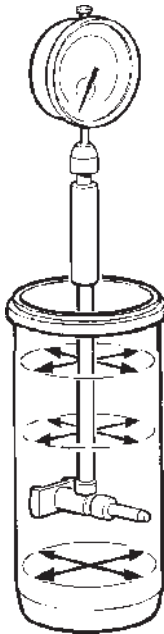

1. Measure the cylinder liner collar wear using a cylinder indicator. To measure the amount of wear as exactly as possible, calibrate the dial indicator first, using a gauge ring or micrometer. Use the cylinder liner original diameter as the basic value.
2. Measure the cylinder liner at the upper and lower turning position and at several points in between. At each measurement location, the measurement should be taken in the engine length - as well as cross direction.
3. If wear is greater than 0.45–0.50 mm (0.018–0.020") a new complete lining kit should be used (piston, liner, piston rings, piston pin and seals). Oil consumption is also of importance for determining when to replace cylinder liners.
4. Remove the cylinder liner and check for cracks. Be extra careful when checking the liner collar. The Magnaflux method can be used for this check.

Pistons

5. Check the piston ring grooves, damaged circlip grooves, cracks and other damage on the pistons. If the piston has deep scratches in the sleeve surface, the piston (the lining kit) must be discarded. The same applies if the piston has one or several cracks in the gudgeon pin hole or in the bottom of the combustion chamber.
A crack test should be done using the chalk flour process.

Cylinder liner and pistons, replacing (all)

Special tools:

| | |
|------------------------------|---------|
| Turning tool | 9993590 |
| Puller | 9996645 |
| Spacer | 9996394 |
| Spacer | 9996395 |
| Puller plate | 9996963 |
| Press tool, 7 ea | 9990157 |
| Drift | 9996599 |
| Prying tool | 9998511 |
| Piston ring compressor | 9990158 |

Other special equipment:

| | |
|---|---------|
| Torque wrench, 10-100 Nm (7.38 - 73.8 lbf ft) | 1159794 |
| Torque wrench, 40-340 Nm (29.5 - 250.8 lbf ft) | 1159795 |
| Dial gauge | 9999876 |
| Holder | 9992479 |

Removal

Cylinder head, oil pan, bracing frame and piston cooling nozzles removed.

⚠ WARNING! It is important to remove the piston cooling nozzle before the piston is removed. Damaged nozzles can cause extensive engine damage.

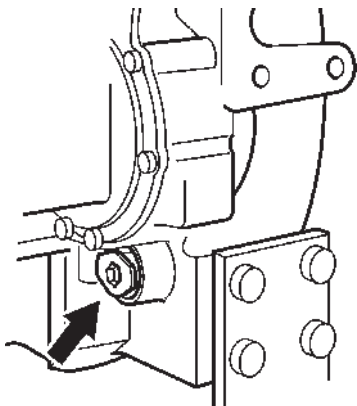

1. Remove the protective cover in the flywheel casing and install turning tool 9993590. Turn the crankshaft so you can access the screws to the connecting rod that is to be removed.

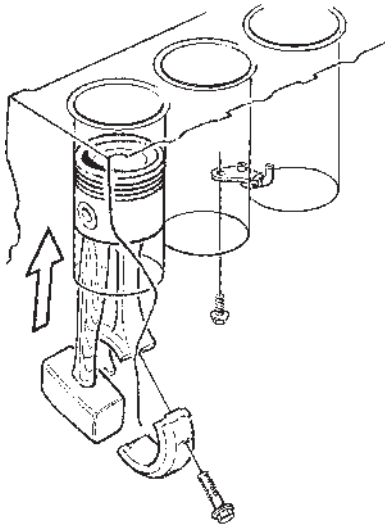

2. Remove main bearing cap and bearing shells.
3. Remove the piston together with the connecting rod.

⚠ IMPORTANT! Reinstall the bearing caps on the connecting rod to avoid damage to the parting surface, since this is very delicate.

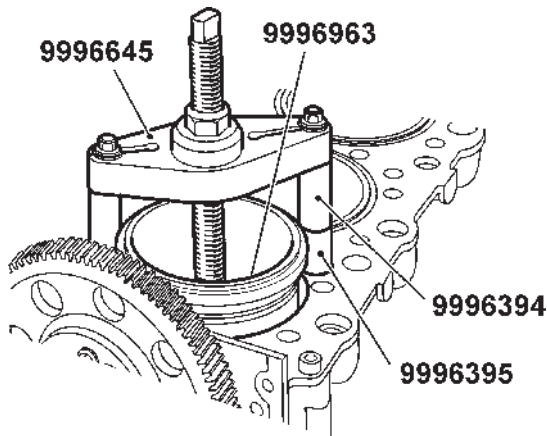

4. Pull the cylinder liners from the block using puller plate 9996963, puller 9996645 and spacer 9996394. If needed, extend using spacer 9996395
5. Remove the cylinder liner sealing rings.

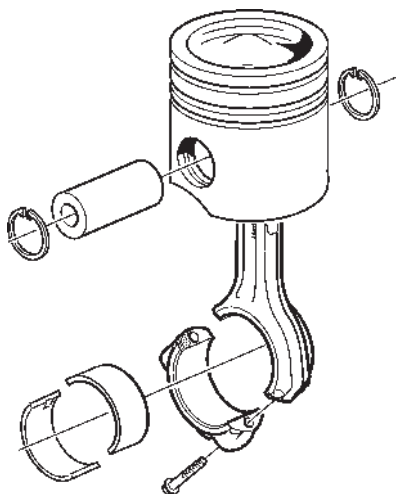

6. Remove the circlips from the piston and press out the piston pin. Remove the piston from the connecting rod.
7. Clean the sealing surfaces in the cylinder block and the grooves for the sealing rings. Do not use scrapes or other tools that can damage the sealing surfaces.

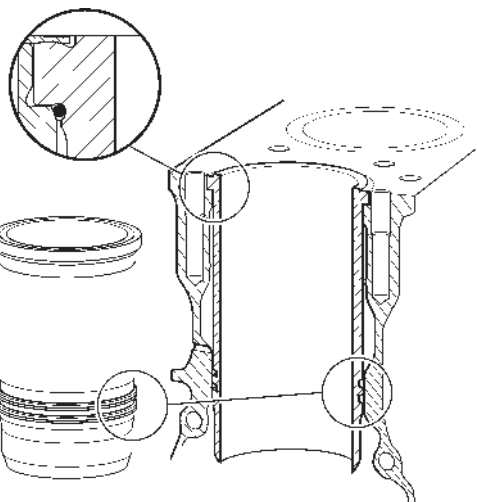
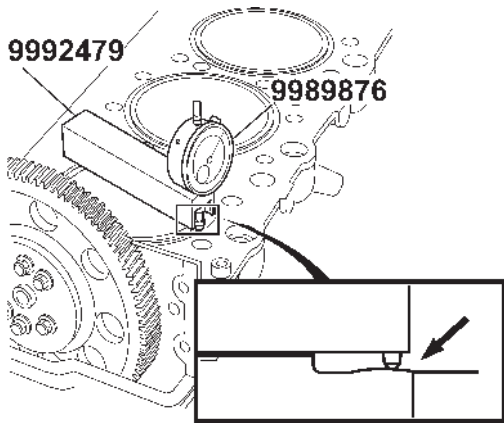
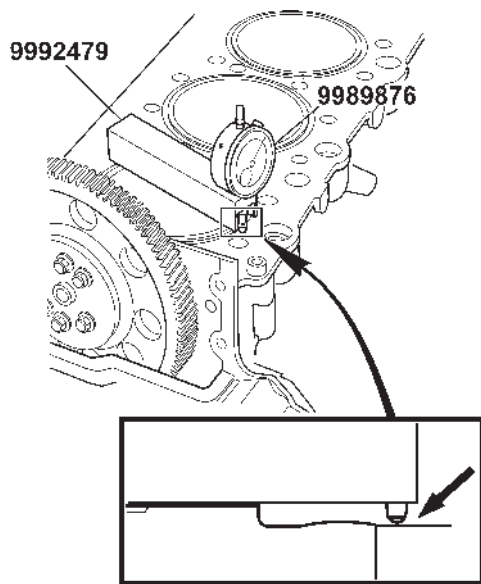

Fitting

8. Check the cylinder block liner collar for damage. In case of damage, the cylinder liner seat must be reconditioned. Fit cylinder liner, **without** seal rings. Hold it using **two** press tools, 9990157.
9. Fit dial indicator 9989876 in holder 9992479. Place the container with the dial indicator across the cylinder liners. Set the dial indicator to zero with a few millimeter pre-load towards the cylinder block plane.
10. Measure the height between the cylinder liner and the cylinder block plane. Measure the liner height at two different, diagonally opposite places. Calculate the average of the two measurements. For correct liner height above block plane, see specifications. If the liner height above block plane is outside specified tolerance, the liner collar in the cylinder block should be machined.

NOTE: Always measure on the highest point of the sealing surface. Mark the liner position in the cylinder block with an India ink pen, so that it is placed in the same position during installation. Repeat the procedure for remaining cylinder liners.
11. Remove the press tools 9990157. Pull the cylinder liner out of the block. Place the cylinder liners in the same order that they were placed, together with adjusting shims.

12. Lubricate the sealing rings with the lubricant supplied with the lining kit and install them on the cylinder liners.

NOTE: The purple seal ring belongs in the lowest groove

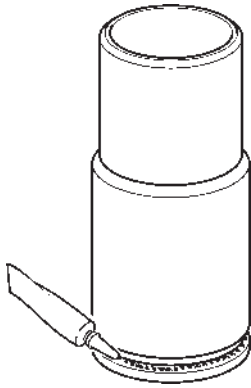

13. When the cylinder liner is fitted **without** shims, an even, about 0.8 mm (0.003") thick bead of sealing compound should be placed on the underside of the cylinder liner collar.

NOTE: Do not put the seal around the entire liner. Leave a 2 mm opening.

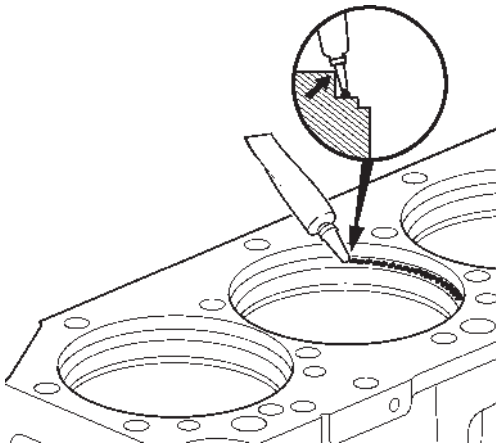

14. If the liner is fitted **with** shims, the sealant bead should be placed on the cylinder block liner seat.

NOTE: Sealant must not be used between the adjusting shims and the cylinder liner collar.

15. **NOTE:** After applying the sealant, the liner must be installed **within 20 minutes**. If the cylinder head cannot be installed and torqued within 20 minutes, the liner must be held to the engine block with two 9990157 press tools.

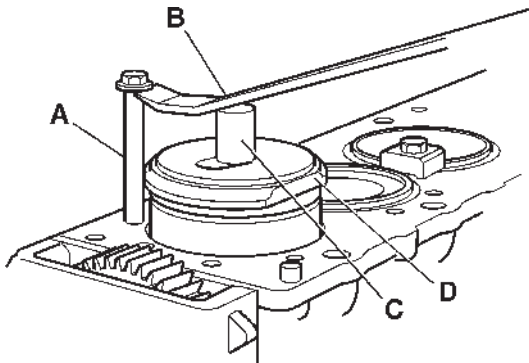

16. Install one of the cylinder head screws (A). Place the tool 9996963 (D) above the cylinder liner together with an appropriate spacer (C) and press the cylinder liner down with prying tool 9998511 (B).

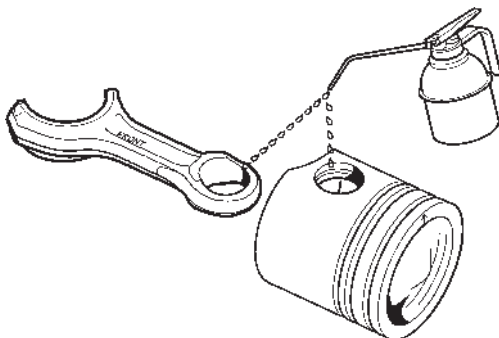

17. Oil the piston pin, the piston bearing seat and connecting rod bushing with engine oil.

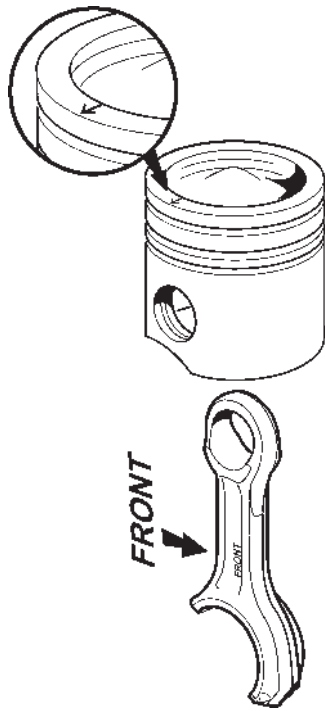

18. Install the connecting rod in the piston with the mark "FRONT" on the connecting rod and the arrow on the piston turned in the same direction. Press in the piston pin.

NOTE: You should be able to press the piston pin in without much force. If the resistance is too big, the piston may need to be heated. The connecting rod should turn freely on the piston pin.

Install the circlips.

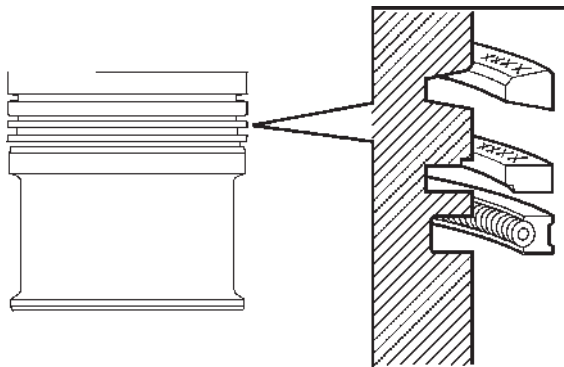

19. Fit the piston rings. Use piston ring pliers. The piston rings openings should be evenly spaced around the piston. The oil ring spring opening should be positioned diametrically opposite the seal openings.

NOTE: The two upper piston rings are marked with letters or point marks. The number markings should be turned **up**. The oil ring is symmetric and can be turned either way.

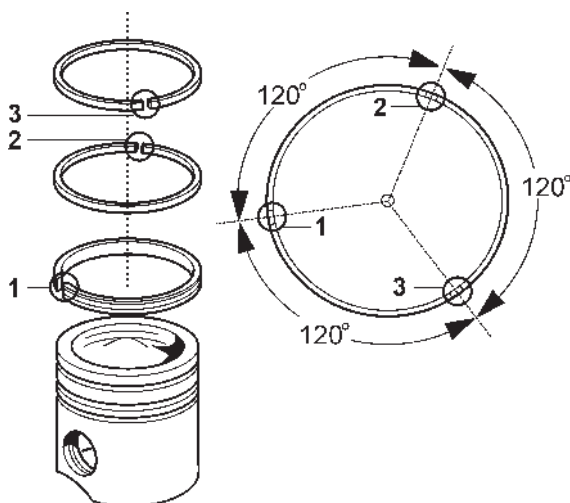

20. Lubricate the piston and the piston rings with engine oil. Check that the piston ring openings are offset 120° in relation to each other.

21. Fit the piston together with the connecting rod.

NOTE: Connecting rods shall be installed in their respective original positions. The arrow on the piston and "FRONT" marking on the connecting rod should point to the front. Use piston ring compressor 9990158.

Temporarily remove the press tool when the piston is fitted. Reinstall the press tool when the piston is in place.

22. Lubricate main bearing caps and the crank bearing pin with engine oil. Fit the big-end bearing shells. Check that they are a correct fit to the connecting rod and caps. Install the main bearing cap per the markings and torque as specified in "Technical data."
23. Clean piston cooling nozzle and check for damage. Install the nozzle and torque as specified in "Technical data."

NOTE: Make sure that the nozzle is aligned with the piston recess.

Crankshaft, inspection

The crankshaft has been induction-hardened.

Inspect the crankshaft thoroughly to avoid unnecessary reconditioning.

To determine reconditioning requirements, the following applies:

1. Thoroughly clean the crankshaft.
Measure the bearing journals for out-of roundness, wear and taper. See specifications in "Technical data."
2. Investigate whether surface damage occurs on the bearing races. If the surface layer is damaged, the shaft should be reground.
3. The crankshaft should be placed on either a pair of V-blocks, under 1st and 7th main bearing journals. Alternatively, hold the crankshaft between stocks.
4. Measure crankshaft alignment (throw) on the 4th main bearing.
For maximum allowable values, see "Technical data."

NOTE: Straightening of the crankshaft is not allowed.

5. Check for cracks before and after any grinding. To check, use a magnetic powder test, i.e. fluorescent powder which can be seen under ultraviolet light.

Main bearings, replacing

Pan removed.

The method describes replacement of main bearings with the crankshaft in place in the engine.

Special tools:

| | |
|--------------------|---------|
| Turning tool | 9993590 |
| Puller | 9990114 |
| Slide hammer | 9996400 |

Removal

1. Install turning tool 9993590.

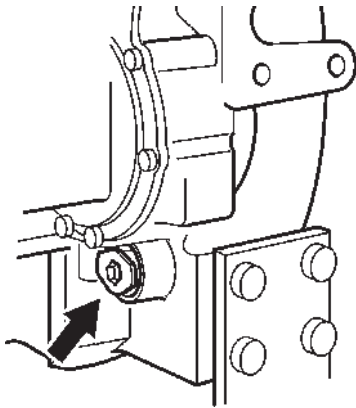

2. Remove the oil suction pipe and oil pump. Remove bracing frame.

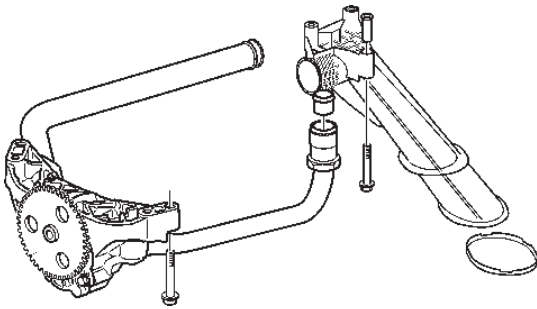

3. Remove one cap.

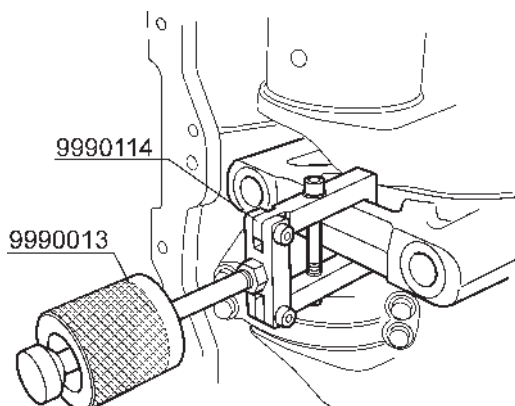

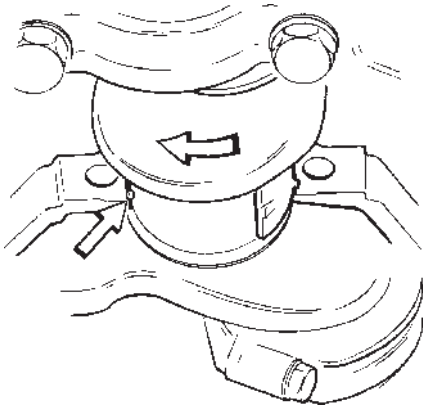

4. Remove the upper bearing shell by placing a pin in the crankshaft oil hole and roll the bearing shell out by turning the crankshaft in the direction of rotation using turning tool 9993590.
5. Clean and check the bearing seat, caps, shaft pivot and bearing shells.
If the bearing has frozen, the reasons should be determined before a new bearing is fitted.
6. Make sure that the correct bearing size is used for replacement.

NOTE: If you are uncertain, check in “Technical data,” which oversize dimensions are shown.

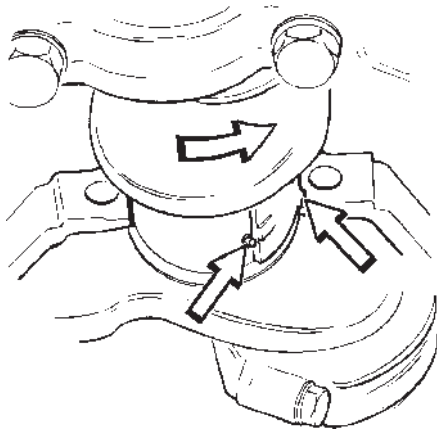

Fitting

7. Oil the shaft pivot and the new bearing shells with engine oil.
8. Install the upper bearing shell by turning the crankshaft using tool 9993590 against the direction of rotation with the pin in the oil hole.

NOTE: Check that the shoulder pressed out of the bearing shell is placed correctly in the bearing seat recess.

Make sure that the upper bearing shells (those to be installed into the cylinder block) are equipped with oil holes.

NOTE: Remove the pin when done.

9. Fit the main bearing cap together with the lower bearing shell.

NOTE: The main bearing caps is asymmetric and can only be installed in one position. Write down the main bearing cap numbers that show their placements if several caps have been removed simultaneously.

Torque caps in two steps, as specified in “Technical data.”

10. Replace the main bearings, one at a time, the same way as the first. Every time you replace the crankshaft, check that it does not seize by turning it using the turning tool 9993590.

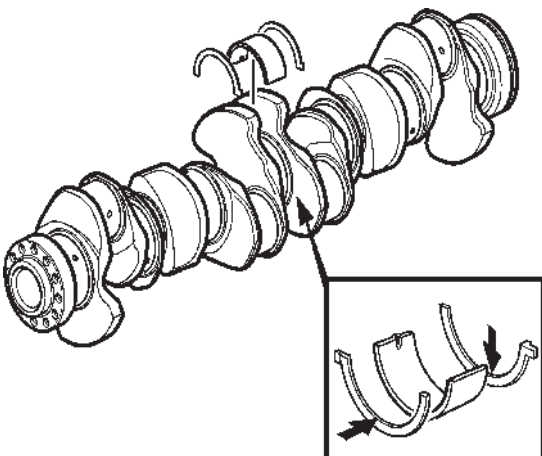

11. Check the crankshaft axial play and replace the thrust washers if the clearance is too big or if the thrust washers are damaged.

NOTE: Axial play is measured using a dial indicator. The thrust washers are available in a number of oversize dimensions. See "Technical data" for oversize dimensions and axial play.

12. The crankshaft thrust bearing pin is placed in the middle main bearing.

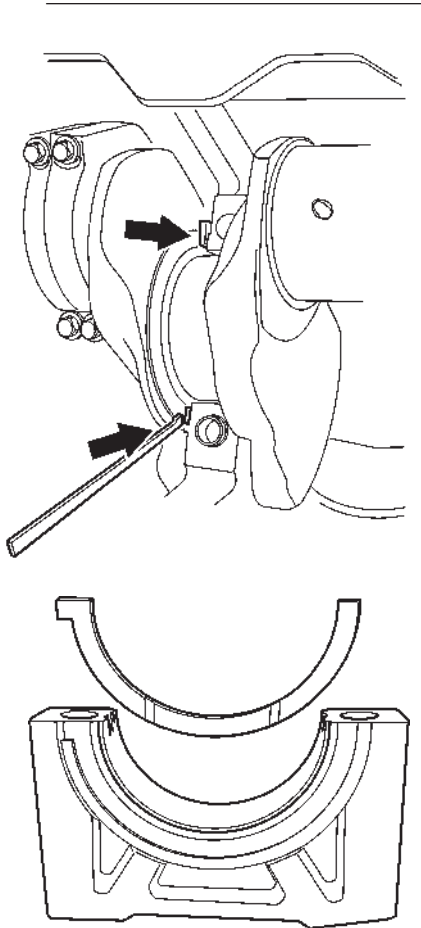

13. Use a narrow plastic or wood stick to remove the thrust bearing washers in the cylinder block bearing seat.

NOTE: The thrust washers can only be placed in one position.

14. Check the axial play of the crankshaft when all main bearing caps have been torqued, see "Technical data" for specification.
15. Install bracing frame and torque as specified in "Technical data."
16. Fit oil pump and oil suction pipe.
17. Remove the turning tool 9993590 from the fly-wheel casing and install the cover.
18. Fit the oil pan.
Add oil and replace oil filter.
Check the oil pressure.

Crank bearings, replacing (all)

Oil pan, oil suction pipe and bracing frame removed.

Special tools:

Turning tool 9993590

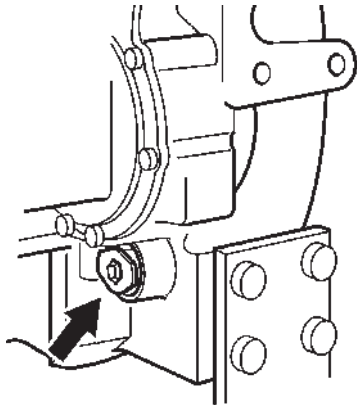

Removal

1. Fit turning tool 9993590 and turn the flywheel until the bearing caps on connecting rod 1 and 6 are in a position where you can remove the screws.
2. Mark and remove thrust bearing caps on connecting rods 1 and 6.

NOTE: Be careful not to damage the surfaces.

3. Remove the bearing shells and clean the connecting rod and cap bearing seats.

NOTE: Make sure the bearing caps are installed on the same connecting rod.

4. Check the bearing pins and the bearing shells.
5. Measure the bearing pins. If any of the values exceed the max allowed, the crankshaft should be removed and remedied.

Fitting

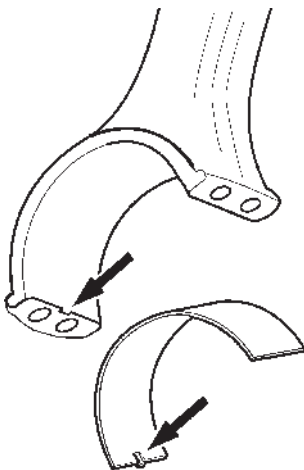

6. Fit the new bearing shells and check that the bearing size is correct. Make sure the bearing shell guide pins is aligned with the connecting rod recess.
7. Oil the bearing shells and the crank bearing pins. Fit the bearing caps and torque the screws as specified in "Technical data."
8. Turn the flywheel so that connecting rods 5 and 2 are in position to remove the screws and repeat points 2-7.
9. Turn the flywheel so that connecting rods 3 and 4 are in position to remove the screws and repeat points 2-7.
10. Check that no crank bearing seizes.
11. Remove the turning tool from the flywheel casing and install the cover.
12. Install bracing frame, oil suction pipe and oil pan. Add oil and replace oil filter. Check the oil pressure.

Flywheel bearing, replacing

Special tools:

| | |
|--------------|---------|
| Handle | 9991801 |
| Puller | 9986173 |
| Puller | 9986179 |
| Drift | 9992269 |

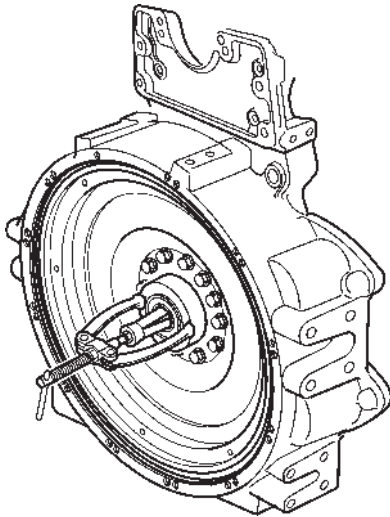

1. Measure the bearing position in the flywheel.
2. Remove the old bearing using tool 9986173 and 9986179.

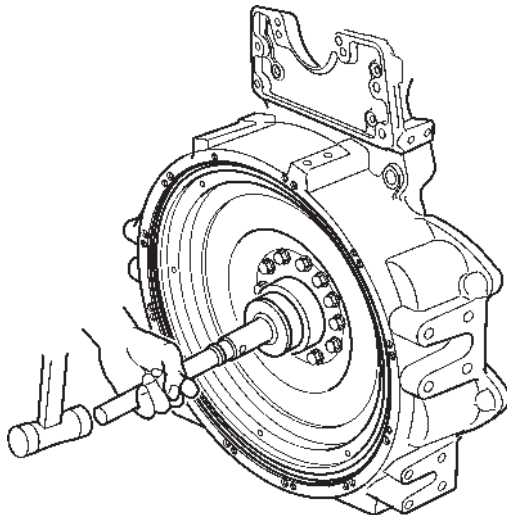

3. Drive in the new bearing to the measured position using tools 9991801 and 9992269.

Flywheel, replacing 21661

Special tools:

Turning tool 9993590
Lifting chain 9996239

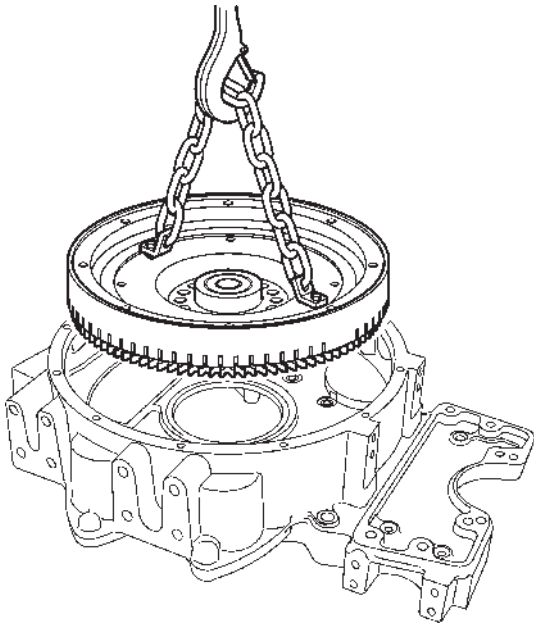

1. Remove the flywheel sensor.
2. Install turning tool 9993590.
3. Secure lifting chain, 9996239, to the flywheel with two screws.
Remove the flywheel retaining screws, Use the turning tool as an anvil.
Lift the flywheel away.
4. Clean the flywheel contact surface on the crankshaft.
5. Clean the flywheel. Check that the tracking surfaces for the flywheel sensor are clean.
6. Check that the flywheel guide pin is correctly inserted into the crankshaft.
Check for damage.
7. Lift the flywheel into position and install the retaining screws.
8. Torque the retaining screws as specified in "Technical data." Use turning tool 9993590 as an anvil.
9. Remove turning tool and re-install the cover.
10. Check the flywheel sensor distance (see "Flywheel sensor distance, checking") and install the flywheel sensor.

Ring gear, replacing

21687

Flywheel removed.

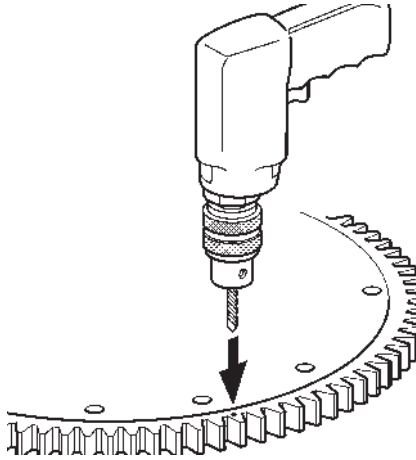

1. Drill 1–2 holes between teeth on ring gear.
Crack the ring gear at the drilled hole using a chisel. Lift the ring gear away from the flywheel.
2. Brush the flywheel bed clean with a steel wire brush.

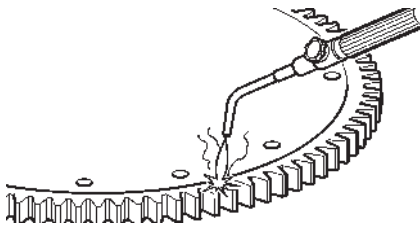

3. Heat the new ring gear to 180 - 200 °C (356 - 392 °F) with a welding torch or in an oven. Ring gear should be heated evenly. Take care not to overheat the ring gear since this would make it run out.
Check the heating by polishing the ring to a shine in a few places. Interrupt the heating when the polished surfaces are blued.

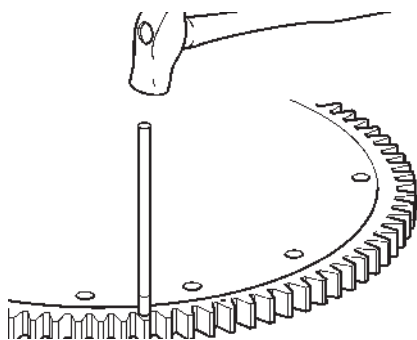

4. Place the heated ring gear on the flywheel and tap it in position with a soft drift and hammer.
Allow the ring gear to cool down.

Flywheel sensor distance, checking

Special tools:

Turning tool 9993590
 Measuring instrument 9998517

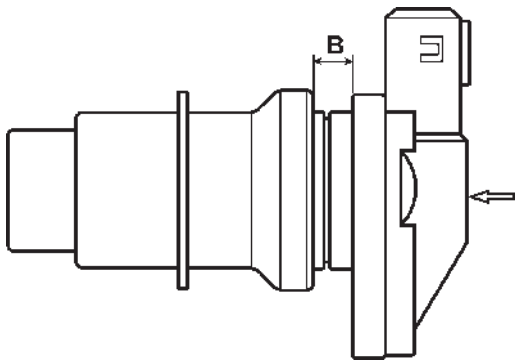
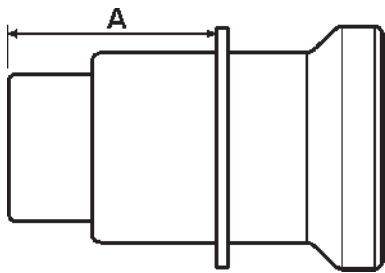
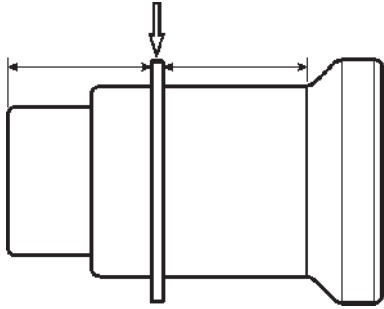

1. Install turning tool 9993590 and turn the engine's flywheel to 0°.
2. Remove the flywheel sensor.
3. Slide the installation tool circlip so that it is placed around the tool's middle.

4. Fit the tool in the sensor hole and press the tool in with care until it touches the flywheel.
5. Remove the tool and measure the distance between the circlip and the end of the tool. Write down the value measured (**A**).

6. Place the sensor in the tool and measure the distance between the sensor bracket contact surface and the end of the tool. Write down the value measured (**B**).

7. Calculate the existing sensor distance (**D**) as follows:

$$D = A - (B + 20) \text{ mm.}$$

Example:

Distance A = 28.2 mm

Distance B = 8 mm

$D = 28.2 - (8 + 20) \text{ mm}$

$D = 0.2 \text{ mm}$

Compare the distance with correct value in "Technical data." As needed; adjust using shims, thickness 0.6 mm (0.024").

8. Install the sensor on the flywheel casing together with any shims.
9. Remove turning tool and install the cover.

Flywheel, indication

Special tools:

| | |
|----------------------|---------|
| Turning tool | 9993590 |
| Dial indicator | 9989876 |
| Magnet holder | 9999696 |

Pressure plate removed

1. Place the dial indicator 9989876 with magnetic stand 9999696 with the probe towards the flywheel.
2. Remove the cover from the engine's flywheel casing. Fit turning tool 9993590.
3. Set the dial indicator to zero. Turn the flywheel and note the maximum value that is measured by the dial indicator. The value should not exceed 0.20 mm (0.0080") at a measuring radius of 150 mm (6 inches).
If the warp is greater, remove the flywheel and check if there is dirt or other irregularities between the flywheel and the crank shaft flange.
4. Remove turning tool 9993590 and install the cover.

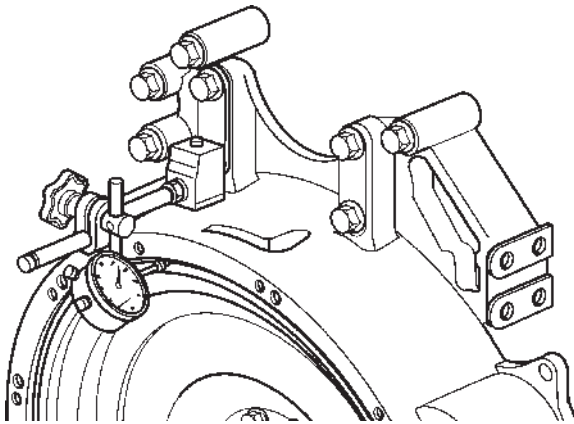

Crankshaft seal, front, replacing 21672

Special tools:

Alt 1

Cone 9990118

Drift 9990112

Drift 9992000

Alt 2

Slide hammer 9996400

Puller 9990192

Cone 9990118

Drift 9990112

Drift 9992000

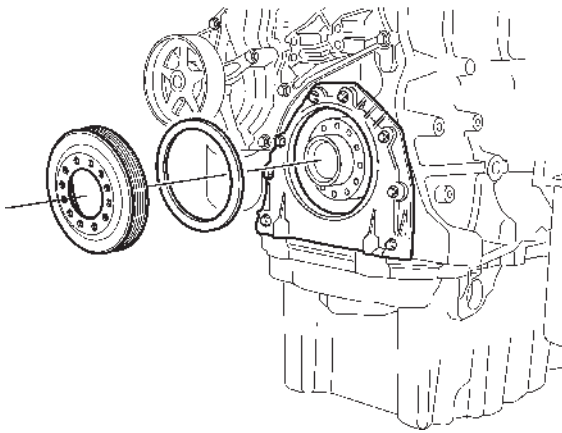

Alternative 1

1. Remove crankshaft belt pulley and the vibration damper (12 screws).

2. Drill 2 \varnothing 3.5 mm (0.138") holes in the seal using the guide holes in drift 9990112. Apply grease to the drill to avoid that dirt enters the engine.

3. Screw in 2 self-tapping screws, 5 mm, in the seal.

4. Install 2 screws, M10 x 60, with long threads in the drift and pull the seal out. Remove the seal and the screws from the tool.

5. Clean the seal area in the casing and the sealing surface on the crankshaft.

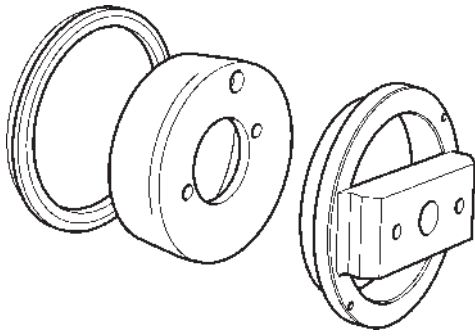

6. Check that the tools are flawless, so you don't destroy the seal.

7. Fit cone 9990118 on drift.

NOTE: No lubrication. Should be installed completely dry.

8. Install the seal on tool 9990112 via 9990118.
Remove tool 9990118.

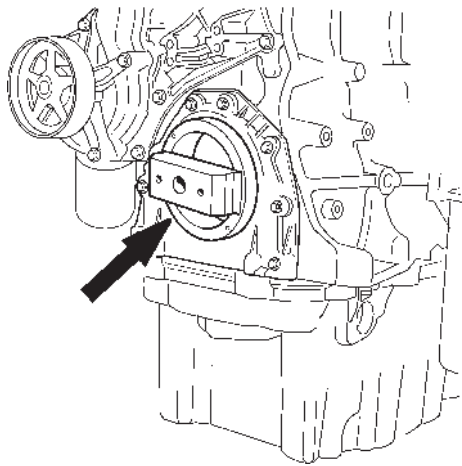

9. Install handle 9992000 on 9990112 and carefully tap in the new seal until the tool bottoms against the crankshaft.

Remove the tool and check that the seal was installed correctly.

10. Fit the vibration damper and the belt pulley.
Torque as specified in "Technical data."

Alternative 2

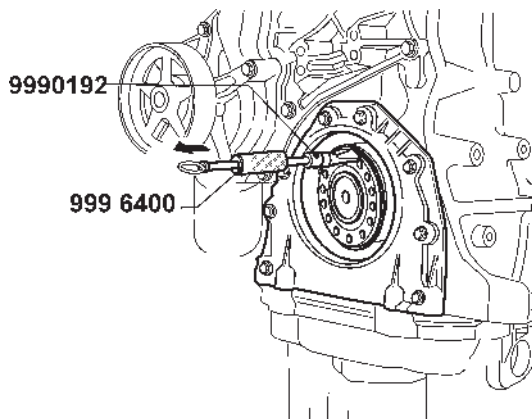

1. Knock out the seal using tool 9990192 together with slide hammer 9996400.

2. Install the new seal. See the points 6-11 in "Alternative 1."

Crankshaft seal, rear, replacing

Flywheel removed.

Special tools:

| | |
|--------------------|---------|
| Slide hammer | 9996400 |
| Tool | 9990166 |
| Puller | 9990192 |
| Drift | 9992000 |

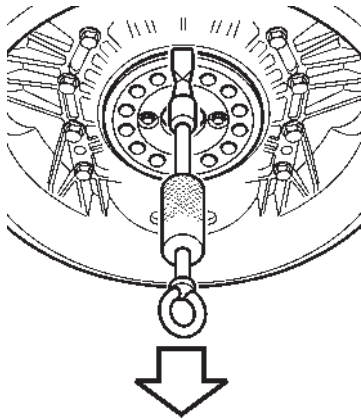

1. Fit tool 9996400 and 9990192 on the old seal by pressing it in or tap it in the with slide hammer.

NOTE: Protect the crankshaft by leaning the tool inward and so that you get a good grip of the seal.

Knock out the seal with the tool.

2. Clean the seal area in the flywheel casing (the transmission gear casing) and sealing surface on the crankshaft (sealing surfaces should be completely clean and dry).

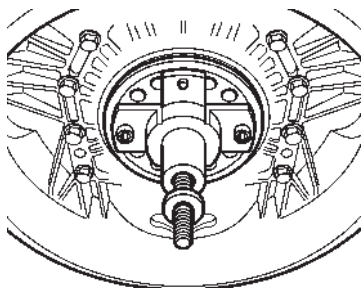

3. Install the tool to the crankshaft and secure it with the bolts. Make sure that plate on the tool rests against the crankshaft before it is tightened.

The washer shall be placed as a shim on the center screw. This determines how far the seal is pressed into the casing.

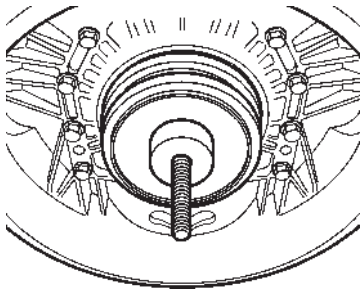

4. Fit the plastic ring that holds the new seal and fit the cover with the screw handle.

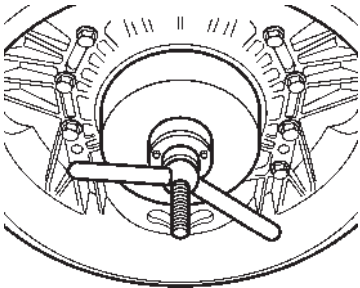

5. Press in the seal using the tool. When the lid bottoms against the tool, the seal will be in the correct position. No lubricants may be used and surfaces should be clean.
6. Remove the tool.

Connecting rod, checking

Important consideration when removing/installing “cracked” connecting rod.

Fitting NEW connecting rod:

Carefully clamp the connecting rod in a vise equipped with soft jaws.

Unscrew the connecting rod screws a few turns and tap carefully on the bearing cap with a plastic hammer until it comes loose.

The crack line may be hard to find when the connecting rod is assembled.

When the bearing cap is separated from the connecting rod, some chip may be missing or come loose. This does not cause any deterioration of the connecting rod function.

Handle connecting rod and caps with care. If impact damage arises on the fracture surface, this may affect the strength following torquing.

⚠ IMPORTANT! Replace connecting rod if the stake or cap is damaged.

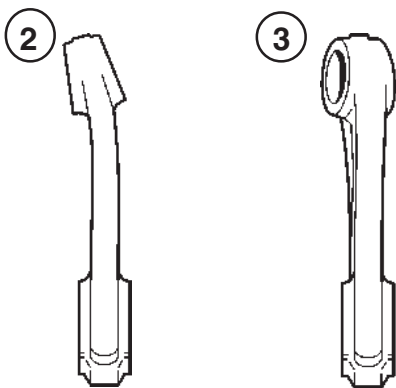

Connecting rod bushing, check measurement

1. Check the connecting rods for cracking, straightness and twist before considering changing the gudgeon pin bush. Discard the connecting rod if it is cracked, bent or twisted.

When replacing connecting rod bushing, the bushing must be machined (connecting rod of trapezoidal shape).

When the clearance is correct, an oiled gudgeon pin should slowly slide through the bush under its own weight.

⚠ IMPORTANT! Regarding max. allowed straightness and twist deviation, see “Technical data.”

2. Use a new piston pin and measure the connecting rod straightness in a fixture.
3. Measure con rod twist.

Valves, removal

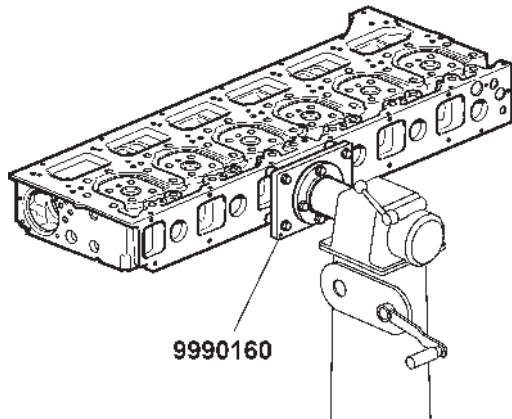

Special tools:

| | |
|-------------------------------|---------|
| Fixture | 9990160 |
| Hydraulic cylinder | 9996161 |
| Press tool | 9990176 |
| Adapter | 9996159 |
| Drift, inlet | 9998246 |
| Drift, outlet | 9990174 |
| Hydraulic pump | 9996222 |
| alt. | 9992670 |
| Valve spring compressor | 9990210 |

The work will be facilitated if the cylinder head is held in an assembly stand with fixture 9990160. Use four screws M8x25.

NOTE: It is important to be very clean when working on the cylinder head. Dirt particles in the fuel channels can destroy or cause operational disturbances for the unit injectors.

Alternative 1

1. Install hydraulic cylinder 9996161 in the press tool 9990176.
2. Install pin 9996159 and drift 9998246 (inlet) or 9990174 (outlet) on the hydraulic cylinder. Place the tool in the holes for the cylinder head retaining screws.
Tighten the tool's nuts.
3. Connect a hydraulic pump, 9996222 (alternatively 9992670).
4. Press the valve spring washer down and remove the valve collets.

NOTE: Check that the tool does not damage the unit injector's electrical connection if the injector stays in place.

NOTE: Place valves and springs in a marked rack to facilitate reinstallation at the same place in the cylinder head.

5. Remove remaining valves the same way as above using the press tool.
6. Remove the oil seals from the valve guides.

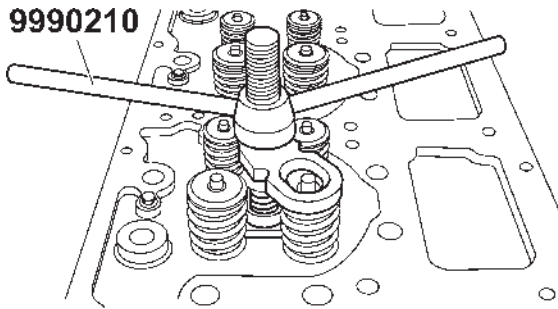

Alternative 2

1. Place the cylinder head on a flat and clean surface. Make sure that the cylinder head is not scratched when the valves are removed.
2. Install press tool 9990210 in the unit injector hole. Secure the tool in the unit injector retainer screw hole, M10 x 30.
3. Place the tool's moving part above the valve spring to be removed. Turn down the tool's "wing-nut" until the valve disc has been pressed down and the valve collets can be removed.

NOTE: Place valves and springs in a marked rack to facilitate reinstallation at the same place in the cylinder head.

4. Remove remaining valves the same way as above.
5. Remove the oil seals from the valve guides.

Valves, fitting

Special tools:

| | |
|-------------------------------|---------|
| Hydraulic cylinder | 9996161 |
| Press tool | 9990176 |
| Adapter | 9996159 |
| Drift, inlet | 9998246 |
| Drift, outlet | 9990174 |
| Hydraulic pump | 9992670 |
| alt. | 9996222 |
| Valve spring compressor | 9990210 |
| Guide sleeve | 9990165 |

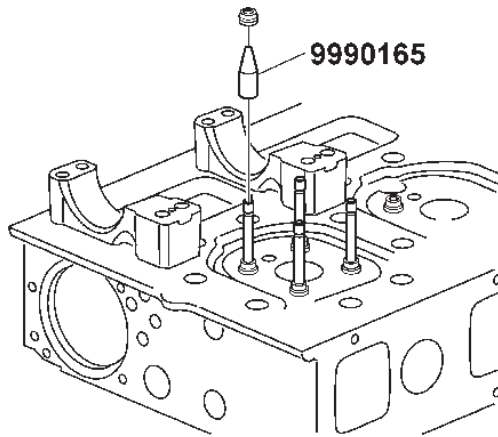

Alternative 1

1. Oil the valve stems and install the valves.
Oil the oil seals.
3. Install tool 9990165 on valve stem and press down the new oil seals above the valve guides.

NOTE: Check that the oil seals have been pressed down all the way.

4. Install the locating pins for the valve calipers. Fit the valve springs and valve spring washers. Press the valve disc down with care and fit the valve collets. Use 9990176 together with the hydraulic cylinder 9996161, pin 9996159 and drift 9998246 (inlet) or 9990174 (outlet), the same way as during removal.

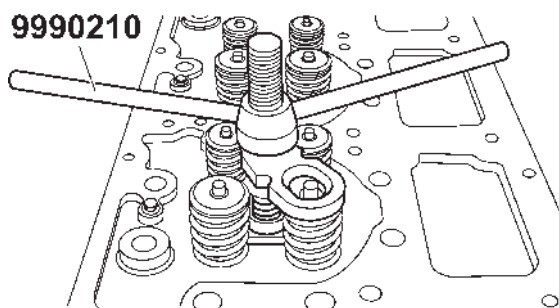

Alternative 2

Alternatively, tool 9990210 can be used instead of hydraulic cylinder, the same way as during removal.

Valve seat, changing

Cylinder head and valves removed

1. The valve seats should be replaced if you cannot get perfect sealing or when the distance "A" exceeds the value shown in the specification. Please refer to the "Technical Data".

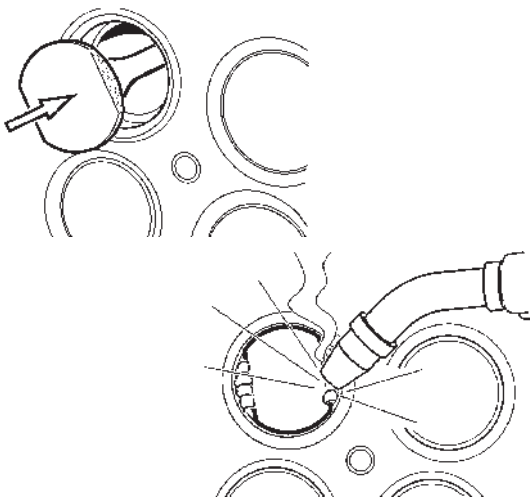
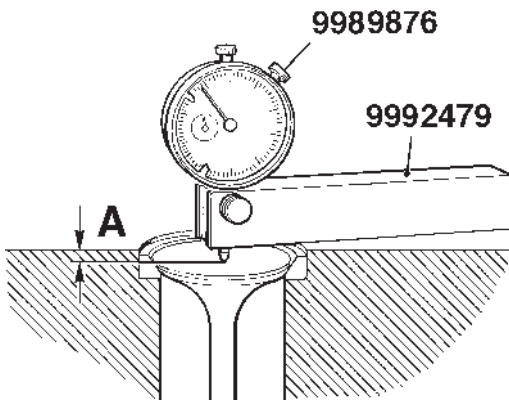

2. Grind the disc on an old valve and weld it to the valve seat. Use a MAG weld or a conventional arc welder (with stainless welding electrode).

⚠ IMPORTANT! Carefully cover other cylinder head surfaces so that any weld splatter will not stick.

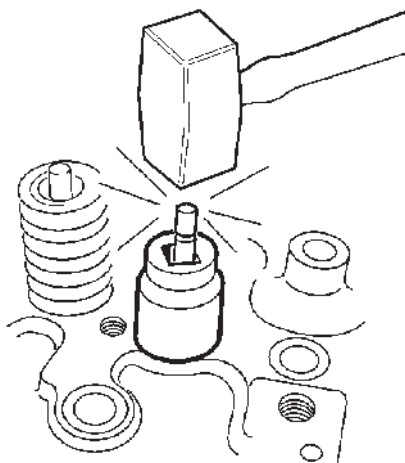

3. Place an appropriate socket over the valves/valve guides and **carefully** tap out the valve seat.

NOTE: Be careful not to damage the cylinder head.

NOTE: Use protective goggles.

4. Thoroughly clean the seat location and check the cylinder head for cracks.
5. Measure the diameter of the valve seat location in the cylinder head. With this measurement as a basis, check whether a standard size seat or an oversize seat is required.

Machine the valve seat location as needed. Please refer to the "Technical Data" chapter.

6. Cool the seat in dry ice to between -60°C and -70°C (-140 to -158°F) and heat the cylinder head by hosing it with hot water or some other suitable source of heat.

Install the valve seat with a drift.

NOTE: Turn the seat with the seat angle towards the tool. Check for leaks against the valve.

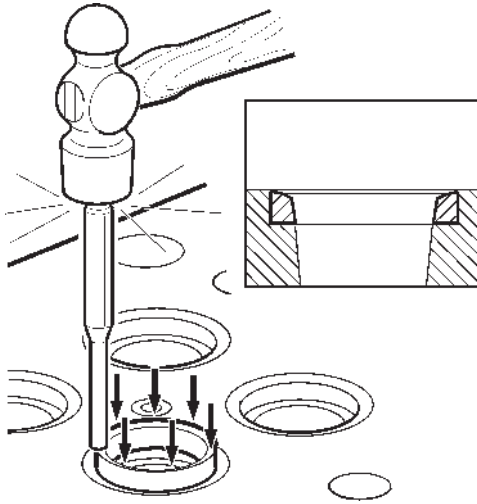

Valve guides, inspection

Cylinder head removed

Special tools:

Dial indicator 9989876

Magnetic stand 9999696

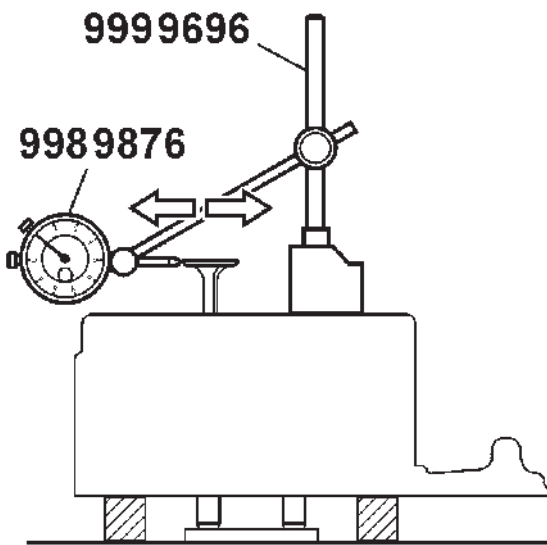

1. Remove the valve shaft seals from the valve guides.
2. Place the cylinder head on the workbench with the valve discs facing up.

⚠ IMPORTANT! The cylinder head must not be put down so its entire weight rests on the valve guides (see figure).

3. Place a **new** valve in the valve guides with the valve stem seal end in the same plane as the guides. Use appropriate anvil under valve stem.
4. Use a dial indicator with a magnetic stand, placing the tip of the dial indicator against the valve disc edge.
Move the valve sideways in the direction of the outlet- or inlet ducts. Note the reading of the dial indicator.
5. Check all valve guides. If the measurements exceed the specifications shown, the valve guides should be replaced. Please refer to the "Technical Data".

Valve guides, replacing

Cylinder head removed

NOTE: If the valve seats too will be replaced, this should be done before the valve guides are removed.

⚠ IMPORTANT! Use protective goggles when pressing the valve guides out or in.

Special tools:

| | |
|---------------------------|---------|
| Adapter | 9996159 |
| Hydraulic cylinder | 9996161 |
| Press tool | 9990176 |
| Drift, installation | 9990183 |
| Drift, removal | 9990184 |
| Hydraulic pump | 9996222 |

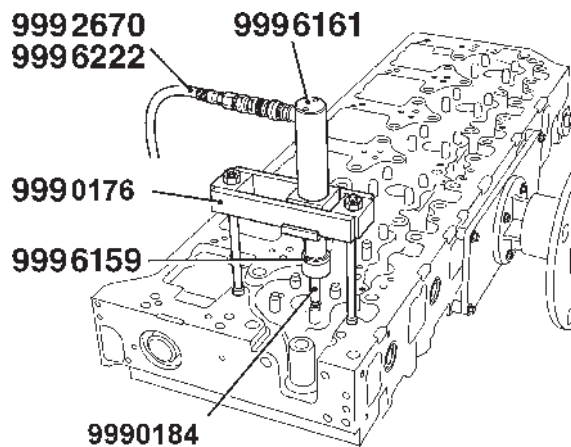

Removal

1. Install hydraulic cylinder 9996161 in tool 9990176.
2. Install pin 9996159 in hydraulic cylinder and press out valve guides with drift 9990184 and hydraulic pump 9996222.
Press out the other valve guides the same way.

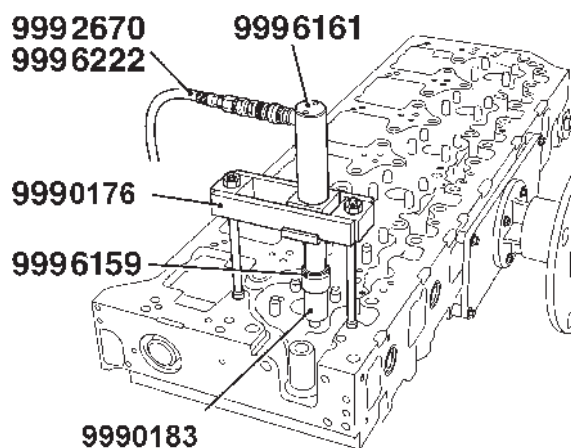

Fitting

3. Oil the valve guide outsides with engine oil before installation.
4. Cool the valve guides.
Press in valve guide using tool 9990183.
Press until the tool bottoms against the cylinder head plane.

⚠ IMPORTANT! Following replacement of the valve guides, the cylinder head must be cleaned to prevent particles from entering the fuel and oil channels. Contamination can destroy or cause operational disturbances for the unit injectors.

Valve seat, grinding

NOTE: As spare parts, the valve seats are fully machined and should not need additional grinding.

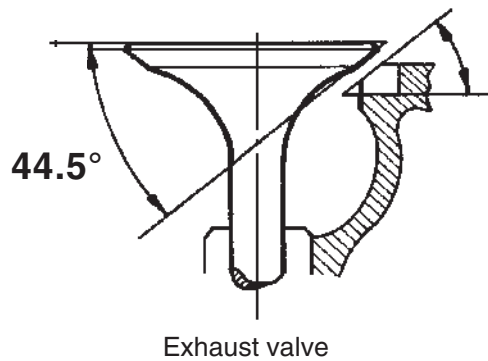
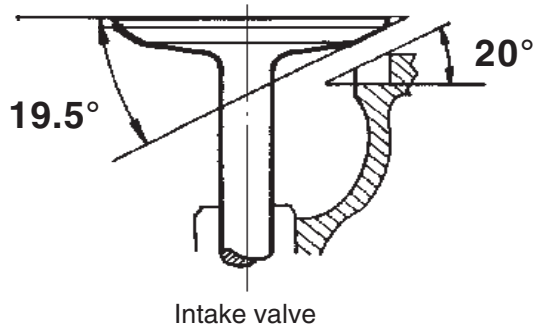

1. Before grinding, check the valve guides and replace them if the wear limits have been exceeded.
2. Grind the valve seat so you don't remove material needlessly, but just enough so the valve seat has the correct form and the valve disc good contact surface.
3. The valve seat is ground so that the dimension between the cylinder head plane and valve disc edge surface conforms to the specification.
4. Valve seat angle is checked with a valve seat gauge after coating the seat contact surface with a light layer of marking paint.

Valves, grinding

Regarding valve sealing angles, See "Technical data."

NOTE: As spare parts, the valves are fully machined and should not need additional grinding.

NOTE: Grind the sealing surface as little as possible. But enough that you remove all damage.

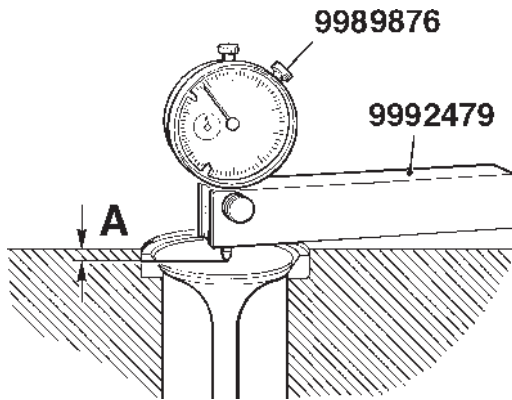

1. Check the dimension (A). If the dimension is larger than the wear tolerance, as specified in "Technical data," the valve should be replaced.

NOTE: Always replace a valve if the valve stem is bent.

2. Check valve straightness using marking dye. If leakage is found, regrind **the valve seat**, see "Valve seat, grinding," and then check again. When the grinding results are acceptable, the valve and seat can be "lapped" together, with a fine grinding paste.

Valve stem seals, replacing

Special tools:

Drift 9990165
Valve spring compressor 9990210
Turning tool 9993590

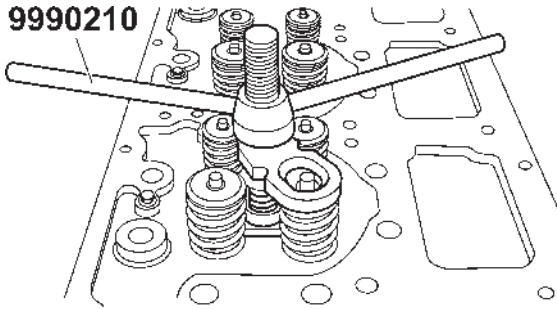

1. Remove electricity from the engine by turning off the main circuit breaker.
2. Remove unit injector, see "Unit injector, replacing."
3. **NOTE:** The piston must be TDC when the valves are removed. This so the valves will not fall into the cylinder. Use turning tool 9993590.
4. Press down the valve springs for cylinder no.1. Use tool 9990210.
5. Remove the valve washers, the valve springs, and the valve collets.
6. Remove the old valve shaft seals.

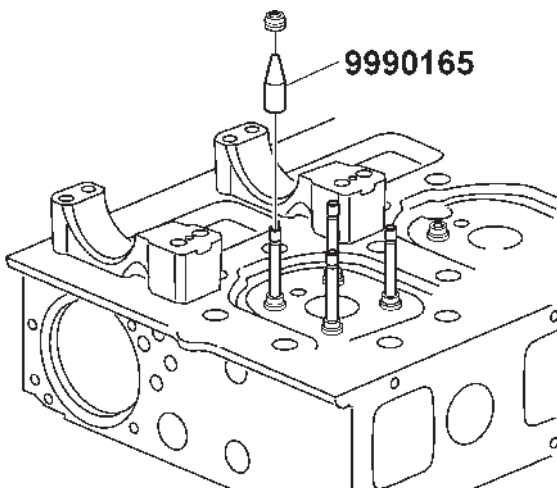

7. Oil the valve stem with engine oil. Fit drift 9990165 on valve stem. Slip on the new seal and place it over the drift.
8. Install valve springs, valve spring washers and valve collet. Carefully tap with a plastic hammer so that the valve collets are positioned correctly.
9. Move the valve spring compressor to cylinder no 6 and repeat the moments per above. Then turn the engine so that pistons 3 and 4 are in the TDC position. Repeat the moments. Continue with cylinders 2 and 5.

NOTE: The piston must be TDC when the valves are removed. This so the valves will not fall into the cylinder. Use turning tool 9993590.

10. Install unit injectors, see “Unit injector, replacing.”
11. Adjust valves and unit injectors, see “Valves and unit injectors, adjusting.”
12. Vent the fuel system. Check for function and leakage.

Cylinder head, pressure testing

Special tools:

| | |
|-------------------------------|---------|
| Pressure testing device | 9990123 |
| Lifting chain, 2 ea | 9996239 |
| Assembly stand | 9986485 |
| Fixture | 9990160 |
| Connection washer | 9990107 |
| Seal plates | 9990164 |

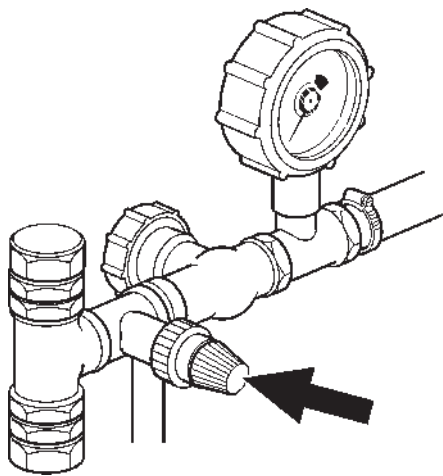

Checking pressure testing device

Check the pressure testing device 9990123 before using it:

1. Connect the pressure testing device to an air supply.
2. Set the pressure gauge to 100 kPa (14.5 psi) with the pressure reduction valve, the knob can be locked using a circlip that is moved axially.

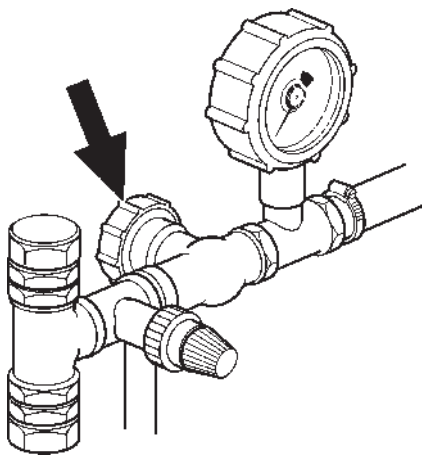

3. Close the shut-off valve. The gauge pressure must not drop for 2 minutes for the device to be considered reliable.
4. Unscrew the pressure reduction valve knob and open the valve.

Pressure testing

21111

Cylinder head removed.

For all lifts of the cylinder head; use 2 lifting chains 9996239, see "Cylinder head, removal"

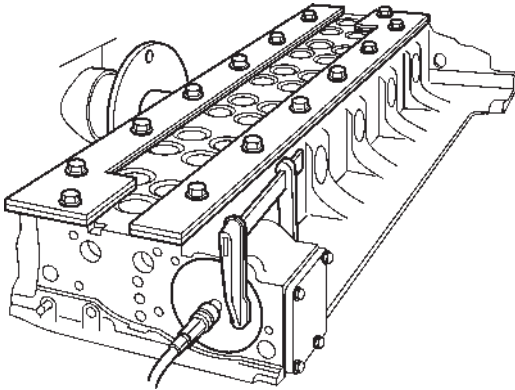

1. Wash the cylinder head.
2. Attach the cylinder head in assembly stand 9986485 using fixture 9990160 and 4 screws, M8x25.
3. Clean contact surfaces on the cylinder head.
4. Fit seal plates 9990164 on the cylinder head using the cylinder head screws and M18 nuts (14 needed).
5. Fit connection washer 9990107 where the thermostat housing goes. Fix the washer with a c-clamp, see figure.
Leave the side cover in place.
6. Leave the temperature sensor in place.
Plug any coolant connections for the compressor.

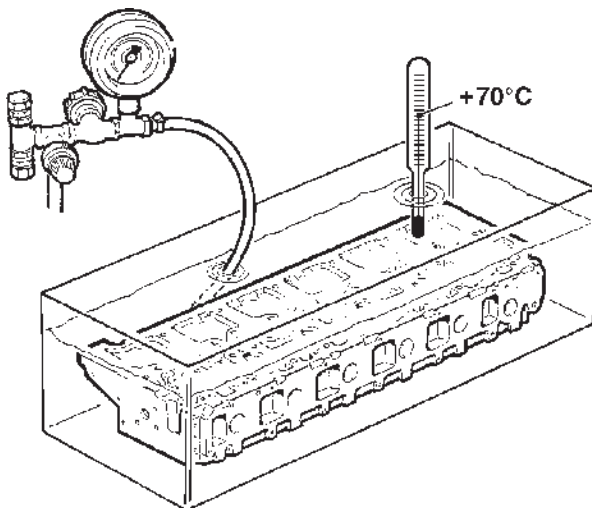

7. Connect pressure gauge hose to connection washer 9990107.
8. Remove the cylinder head including fixture from the assembly stand.
Remove the fixture.
9. Lower the cylinder head into a water bath, +70 °C (+158 °F).
10. Connect air to the pressure testing device.
Open the shut-off valve.
11. Adjust the pressure reduction valve knob so that pressure gauge shows a pressure of 50 kPa (7.25 psi).
Maintain the pressure for one minute.
12. Increase the pressure to 150 kPa (22 psi). Lock the pressure reduction valve knob using the cir-clip.
Close the shut-off valve.

13. After 1-2 minutes, check whether the pressure has dropped, or if bubbles of air can be seen in the water bath.
If you see bubbles, check seal plates and inspect the cylinder head for any cracks.

14. Unscrew the knob on the pressure reduction valve to relieve the pressure in the cylinder head and open the cock.

15. Remove the cylinder head from the water bath.
Attach the fixture.
Attach the cylinder head in assembly stand.

16. Blow the cylinder head dry. Be extra particular with the fuel channels.

NOTE: Make sure that no dirt enters the fuel channel. This may damage the unit injectors.

17. Remove all the sealing washers and any plugs installed for the pressure testing

18. Remove the cylinder head including fixture from the assembly stand.
Remove the fixture.

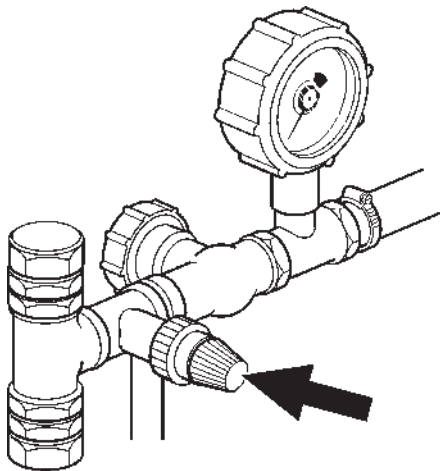

Copper sleeve for unit injector, replacing

Unit injector removed

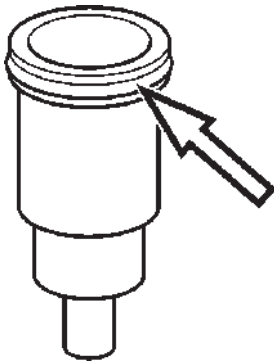

Special tools:

| | |
|---------------------------|---------|
| Thread cutting tool | 9809667 |
| Turning tool | 9993590 |
| Protective sleeve | 9998251 |
| Sealing ring | 9998250 |
| Thread cutting tool | 9998252 |
| Puller | 9998253 |
| Cleaning kit | 9998599 |
| Expander | 9998688 |

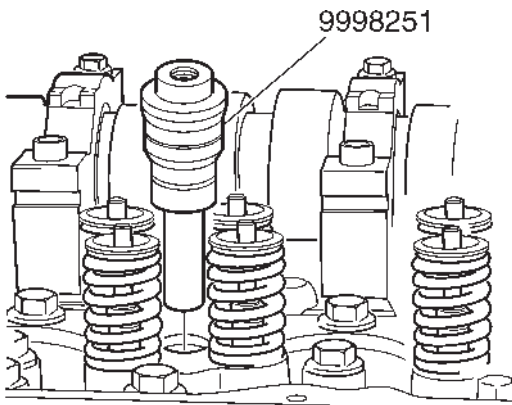

1. Drain the coolant using a hose, 9996049. See "Cooling system, draining."
2. Remove protection plug 9998581.
3. Install 2 sealing rings, 9998250, in order to prevent dirt from entering the fuel channels when the copper sleeve is removed.

NOTE: Ensure that the piston is in its lower position.

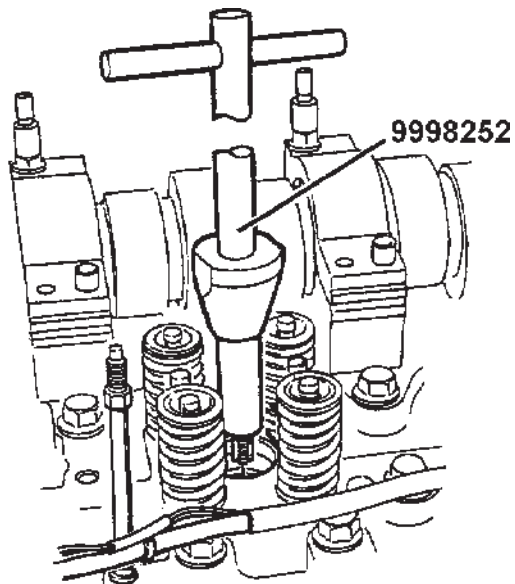

4. Lubricate thread cutting tool, 9809667, with grease in order to prevent chips from falling into the cylinder.
Screw in thread cutting tool at least 20 mm (0.8") in the copper sleeve with tool 9998252.

NOTE: Use thread cutting tool 9809667.

5. Remove tool 9998252 and thread cutting tool.

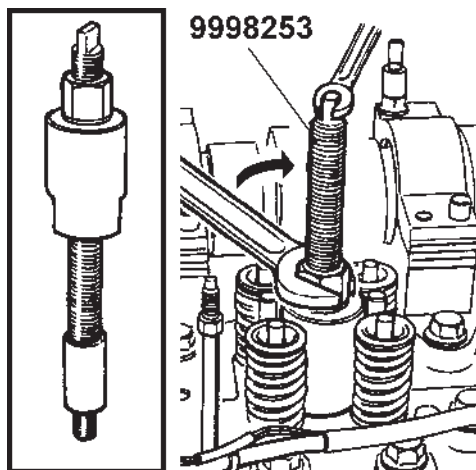

6. Check that the pin 9809668 is installed on 9998253.
Screw in the pin on tool 9998253 **at least 15 mm (0.6")** into the copper sleeve. Remove the copper sleeve by turning the nut while holding the pin.

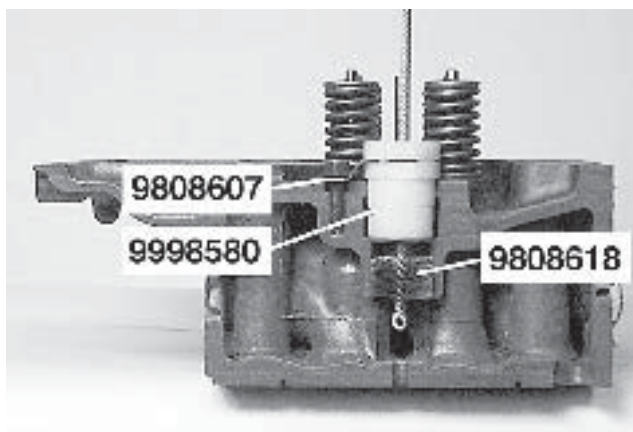

7. Use cleaning kit 9998599 and a power drill before the new copper sleeve is installed.
Install cleaning sleeve 999 8580 in the injector well and fix with holder 9808607 ("the ears" must be cut off so the tool will fit).

NOTE: Tools 9808580 and 9808607 should be used to prevent dirt from entering the fuel channel.

8. Clean the cylinder head walls for the copper sleeve using 9808618.

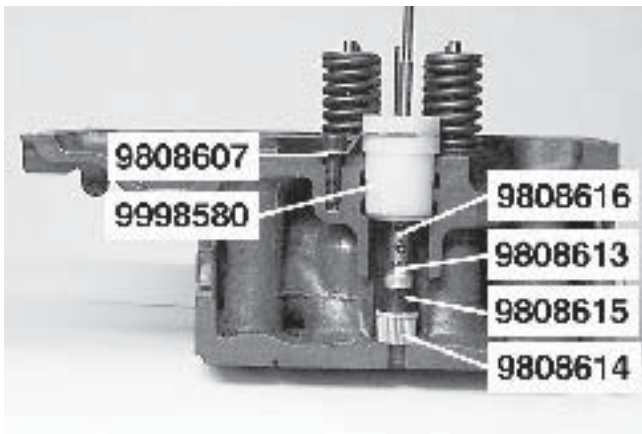

9. Clean the copper sleeve seat with brush 9808614 together with handle 9808616 and the holders 9808613 and 9808615.

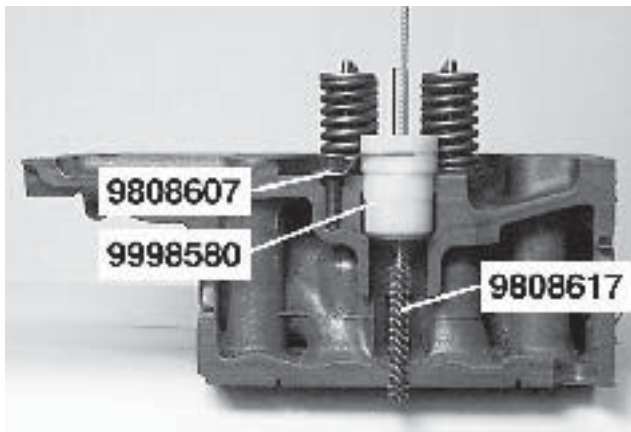

10. Clean the cylinder head hole with brush 9808617.
11. Remove the tools 11 980580 and 9808607.

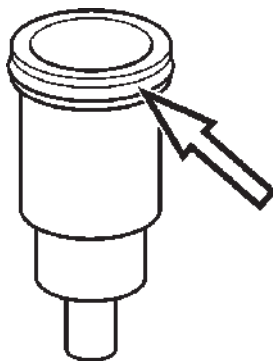

12. Check that the piston is located in its lower position in the cylinder.

NOTE: This should be done so that tool 9998688 does not damage the piston due to its length.

13. Lubricate in the **new** seal ring on copper sleeve with soapy water.
14. Place the copper sleeve on tool 9998688.

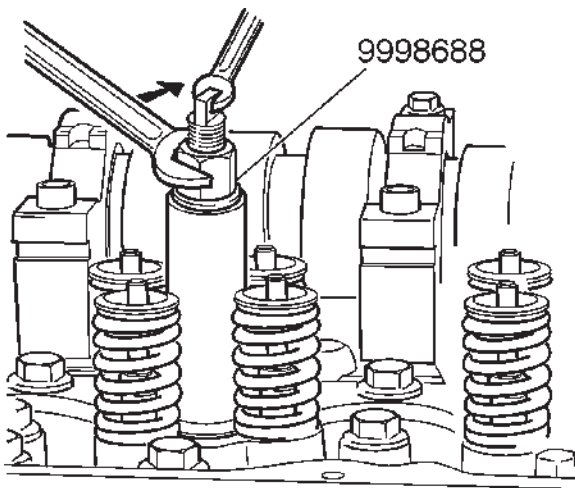

15. Oil the pin on tool 9998688. Lubricate between nut and tool.
16. Press the copper sleeve down **carefully** so that the drifts are guided towards the unit injector space (the edge) in the cylinder head. Check that copper sleeve bottoms in the cylinder head. Install unit injector yoke and tighten.
17. Enlarge the copper sleeve with a drift by screwing on the nut while the spindle is held steady until the enlarging drift has been pulled all the way through.

NOTE: After installation of new copper sleeve follow instructions for “torquing of unit injector yoke” in “Technical data.”

18. Remove the sealing rings 9998250.
19. Install the unit injector. See “Unit injector, replacing” .
20. Re-install the valve calipers as marked.
21. Install the rocker bridge and check clearances for valves and unit injectors.
22. Install the valve cover.
23. Fill coolant and check for leaks.

Camshaft, checking for wear

Rocker bridge removed

Place a steel ruler above the ridges in the camshaft's lengthwise direction in order to check if the cam profiles are worn.

Measure wear using a feeler gauge or wire gauge. As an alternative you can use a digital depth slide gauge. Compare the measured values with the values shown in "Technical data."

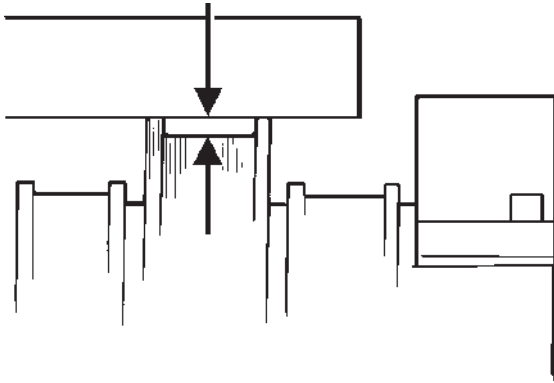

Replacement guidelines

Under normal circumstances, irregularities on the surface of the engine's cam shaft ridges. This does not mean that the camshaft must be replaced. These marks have no detrimental effect on either the engine's performance or durability of the engine and its components.

Examples of acceptable wear and not acceptable wear are shown below.

Acceptable wear.

The camshaft does not need to be replaced.

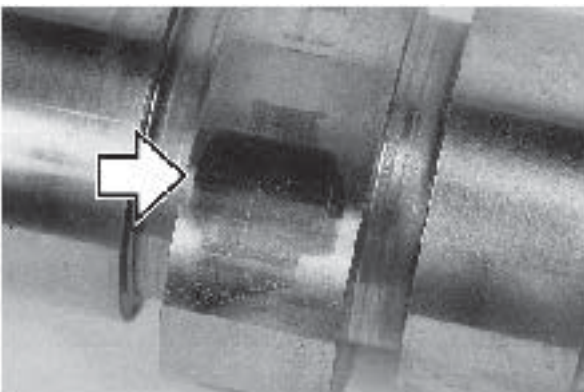
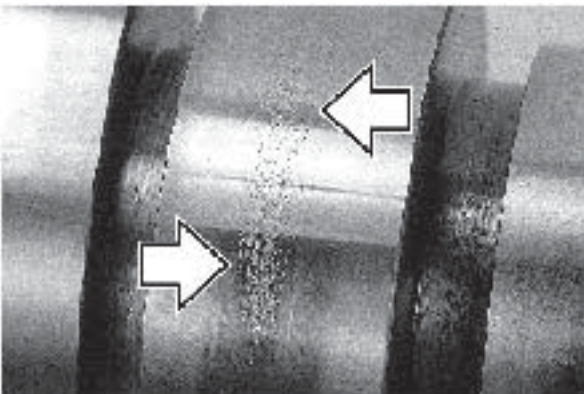

Not acceptable wear.

NOTE: Camshaft with rocker arms must be replaced.

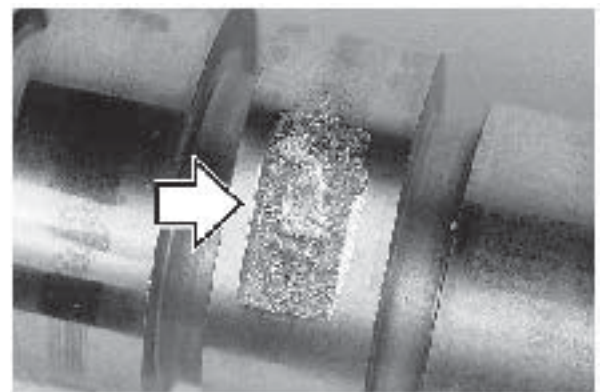
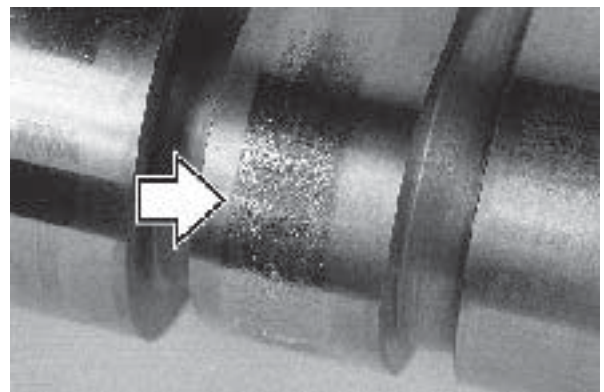

Camshaft bearing housing, replacing

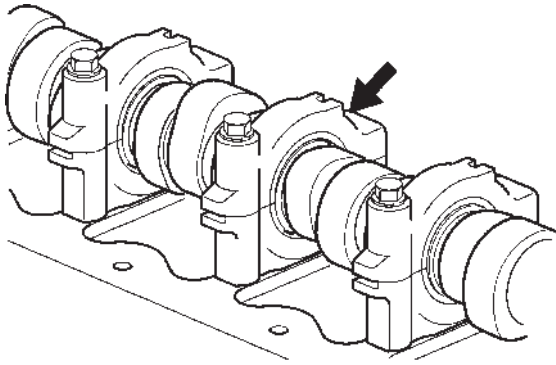

Factory installed bearing housings have been machined with the cylinder head and must not be moved from one cylinder head to another.

Therefore, the first time one or more bearing housings are replaced, all bearing housings must be replaced so that the positions of the bearing housings can be inscribed. Bearing housings can then be replaced individually.

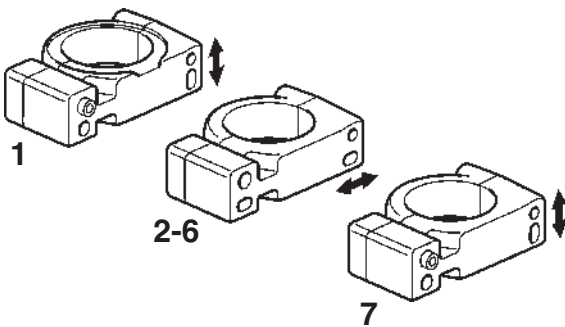

The holes for the guide sleeves are oval in the replacement housings, which allows radial adjustment of the middle bearing housing and axial adjustment of the front and rear bearing housings.

If a replacement housings is being installed, mark them with numbers so that they can be reinstalled in the same place as before if they must be removed.

Camshaft sensor distance, checking

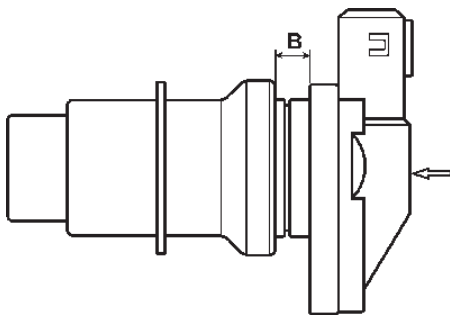
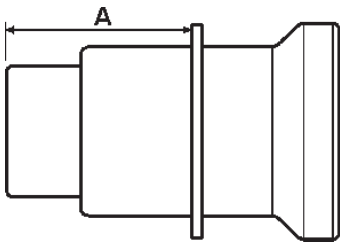
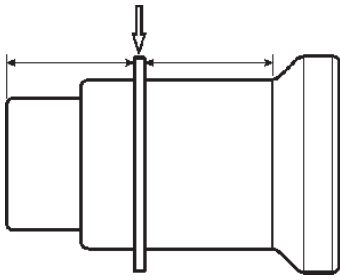

1. Turn the engine so that a tooth on the camshaft drive is aligned with the cam shaft sensor hole on the upper transmission gear casing.
2. Slide the installation tool circlip so that it is placed in the middle of the tool.
3. Place the tool in the camshaft sensor hole and press it in with care until it touches the vibration damper tooth.
4. Remove the tool and measure the distance between the sensor contact surface and the end of the tool.
Write down the value measured (A).
5. Place the sensor in the tool and measure the distance between the sensor contact surface and the end of the tool (B).
6. Calculate existing sensor distance (D) as follows:
 $D = A - (B + 20)$
 Example:
 Distance (A) = 28.2 mm
 Distance (B) = 8 mm
 $D = 28,2 - (8 + 20)$
 $D = 0,2 \text{ mm}$
7. Compare the value with correct value per "Technical data." Adjust as needed using shims. Install the sensor together with any shims.

| Clearance measured | Adjusting shims | |
|--------------------|-----------------|----------|
| | Quantity | item no. |
| 0.2 - 1.0 mm | - | - |
| -0.3 -0.3 mm | 1 | 1677894 |
| -0,6 - (-0,3 mm) | 2 | 1677894 |

Transmission, replacing

Valve cover, cable harness, upper transmission casing, camshaft sensor, oil pan, and oil pump have been removed.

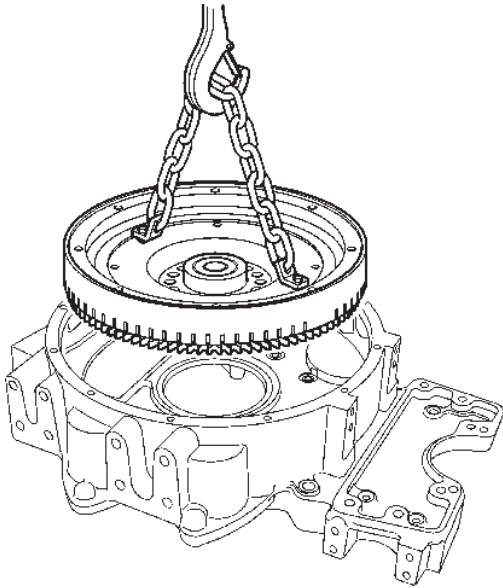

Removal

1. Remove the flywheel sensor.
2. Turn the engine to TDC on the camshaft, check that the mark on the flywheel is at "0."
3. Secure lifting chain 9996239 in the flywheel. Remove the flywheel.

⚠ WARNING! Pinching hazard. The flywheel weighs about 40 kg (88 lbs).

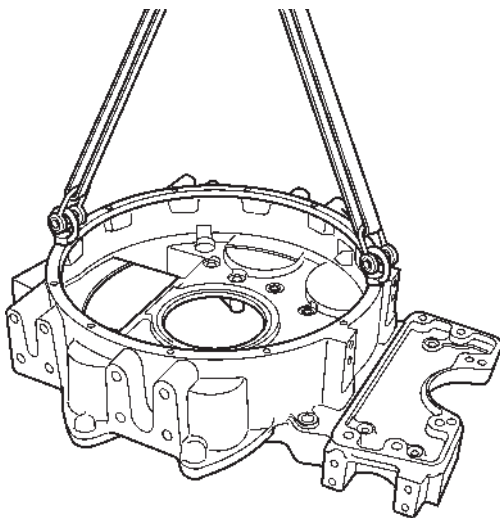

4. Remove the starter motor, rear lifting eye and fuel pump together with servo pump, the cover and any rear engine mounts.
5. Remove flywheel casing screws. Remove the casing using lifting eyes and lifting strap.

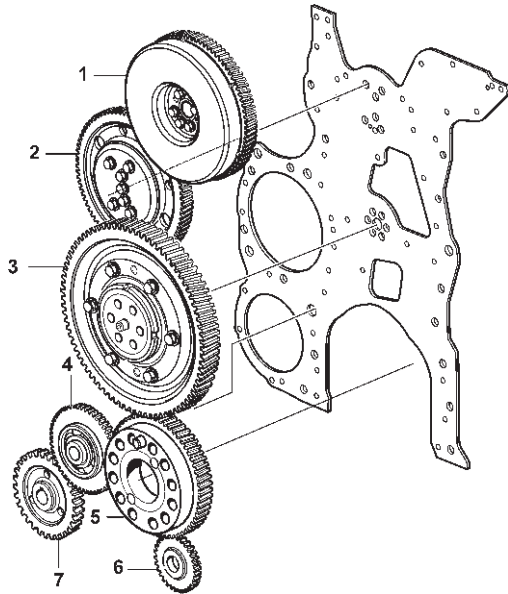

- 1. camshaft drive
- 2. upper intermediate gear
- 3. dual drive
- 4. lower intermediate gear
- 5. crankshaft drive
- 6. oil pump drive wheel
- 7. drive wheel for fuel feed pump / servo pump

6. Remove the lower intermediate gear (4).
7. Remove the camshaft drive (1).
8. Remove the two screws on the crankshaft drive (5) and remove the drive using a suitable puller.
NOTE: To protect the puller thread, place a thick washer between the piston ring tool and the crankshaft.
9. Remove the six socket head cap screws in the hub of the double drive (3) and remove it complete.
10. Remove the upper intermediate gear (2).
NOTE: Save the spacer plate behind the drive and write down how it is installed.
11. Remove the transmission plate and clean both sides.

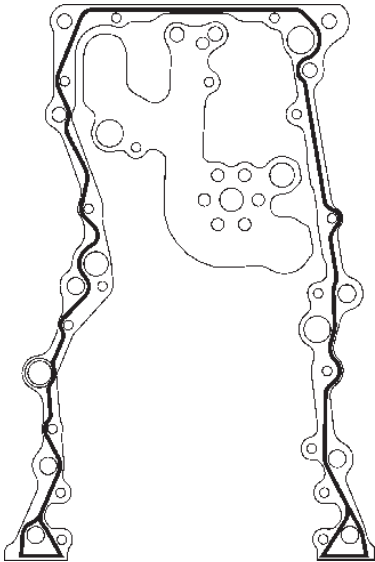

Fitting

NOTE: Lubricate the inside of the gears before you place them.

1. Apply a 2 mm (0.080") thick string of sealant on the engine block and the cylinder head, as shown.
2. Install the transmission plate. Use new screws that are pre-treated with locking compound. Torque as specified in "Technical data."

NOTE: Torque within 20 minutes after sealant has been applied.

3. Oil the spacer plate and place it together with the upper intermediate gear (2). Torque gently, max 10 Nm.

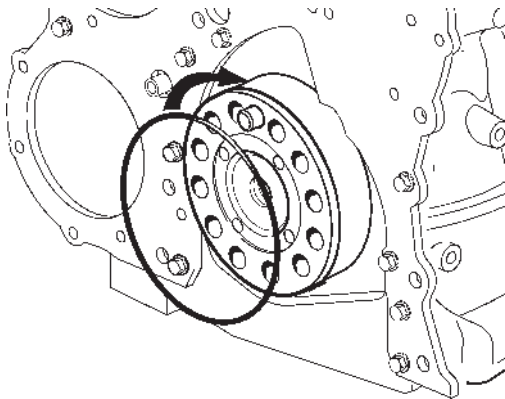

4. Install a new o-ring on the crankshaft.
5. Fit the crankshaft drive (5) and torque socket head cap screws as specified in "Technical data."

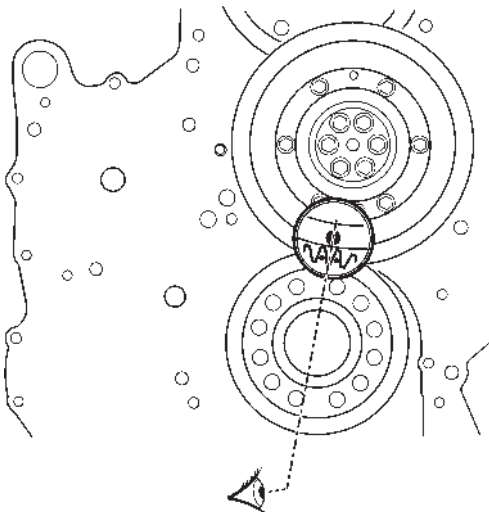

6. Install the double drive kit (3) with the hole marking between the two hole markings on the crankshaft drive.

NOTE: The double drive inner and outer gears, respectively, have different gear pitch. For the camshaft to be set correctly, the markings must be correct.

Torque the screws as specified in "Technical data."

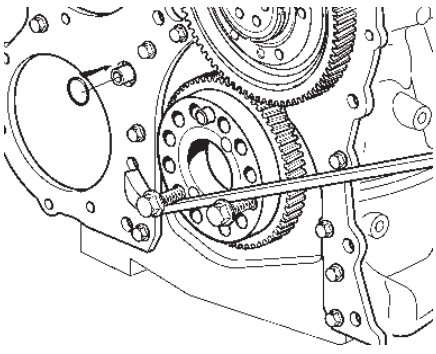

7. Install the bottom intermediate gear (4) with a new O-ring.
8. Install the lubricating oil pump.
9. Place two screws in the crankshaft drive so you can attach a crowbar and thus be able to turn the crankshaft as needed.

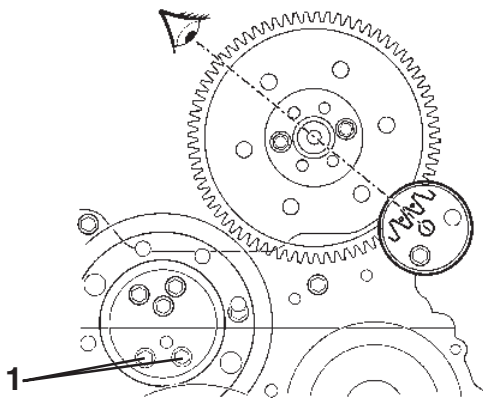

10. Fit the camshaft drive (5) without the vibration damper, use nuts for spacers.
11. Place the drive so that the reference hole in the transmission plate lies between the drive markings.
Tighten two screws temporarily with low torque, max 10 Nm (7.4 lbf ft).
12. Remove the 2 lower screws (1) in the adjustment wheel. Check that the upper screws are not tightened.

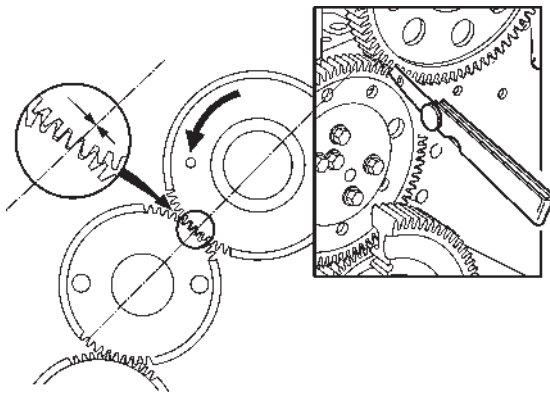

13. Place a 0.1 mm feeler gauge the pressure side. Turn the camshaft drive against the feeler gauge. Torque the upper intermediate gear per step 1 in "Technical data."
Remove the feeler gauge.

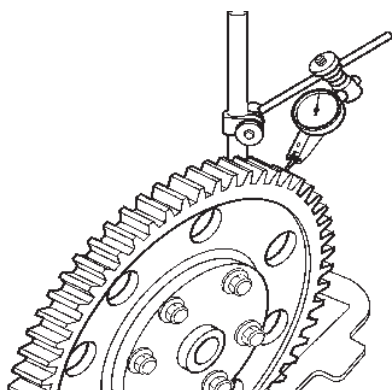

14. Check the clearance as follows:
Fix the adjustment wheel.
Place a dial indicator on the camshaft drive, as shown.
Turn the drive back and forth and compare the result against the specification for gear backlash in "Technical data."
15. If gear backlash is correct; torque the screws on the intermediate gear (1) per step 2 in "Technical data."

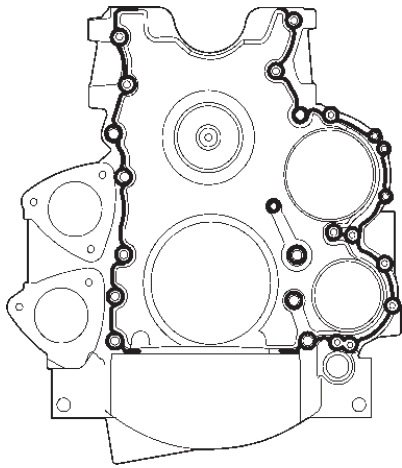

16. Remove the crankshaft seal and apply new sealing compound to the flywheel casing, against the engine block.
17. Install the flywheel casing. Check that the casing is aligned with the bottom edge of the engine block.

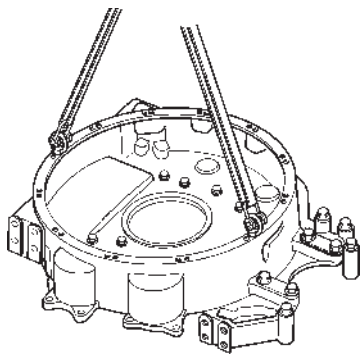

18. Install new crankshaft seal. See "Crankshaft seal, front, replacing"

NOTE: No lubrication. Should be installed completely dry.

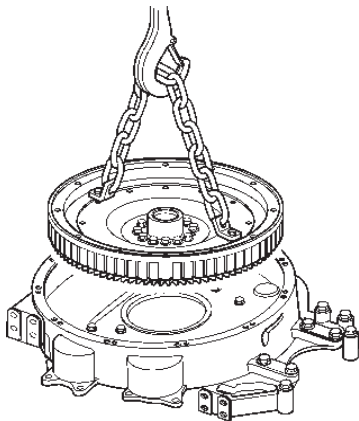

19. Install the flywheel and torque as specified in Technical data. See "Flywheel, checking for warp."
Install the flywheel sensor and adjust it. See "Flywheel sensor, checking."
20. Place the camshaft's vibration damper into position and torque as specified in "Technical data."

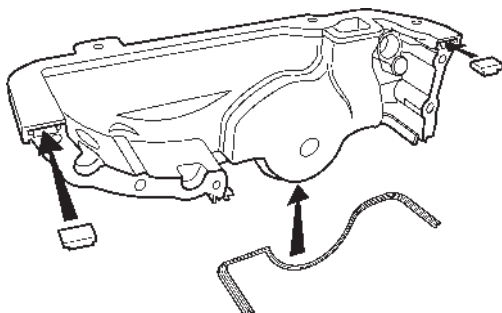

21. Apply a 2 mm (0.080") thick string of sealant to the upper transmission gear casing contact surface, as shown.
22. Fit the rubber seals and install the upper transmission gear casing.

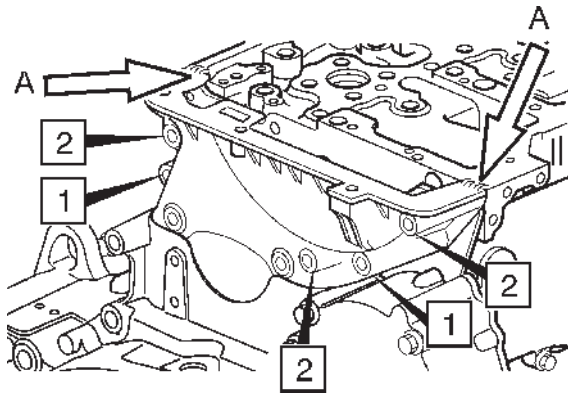

23. Only fit the screws (1) and tighten by hand. (The holes are oblong so that you can press the casing down towards the rubber seal.)

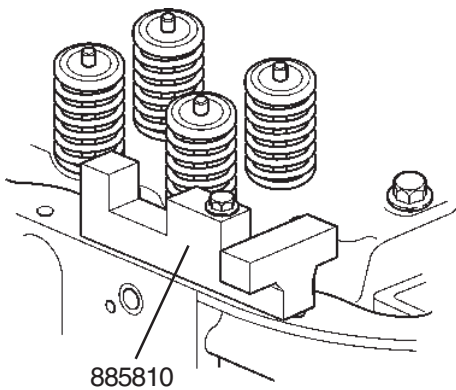

24. Press the casing down with the tools 885810 and 9998601 so that the cylinder head and the upper transmission gear casing sealing surfaces are aligned.

Refit the other bolts (2).

Torque as specified in "Technical data."

NOTE: The transmission gear casing must be installed and torqued within 20 minutes after sealant application.

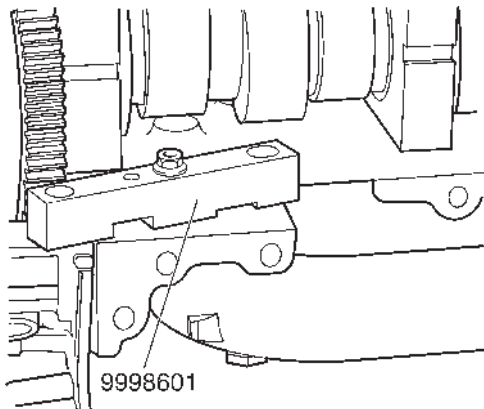

25. Install camshaft sensor and adjust per "Camshaft sensor, checking."
26. Reinstall other components that were removed.

Group 22: Lubrication system

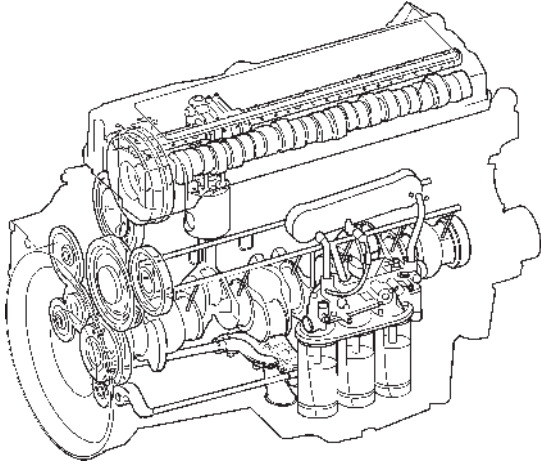

When working with chemicals, fuel and lubricating oil

⚠ Important! Lubricate hands with a barrier cream and always use protective gloves during work where you risk contact with oil, fuel, etc. Continuous skin contact with engine oil dries the skin and can be damaging.

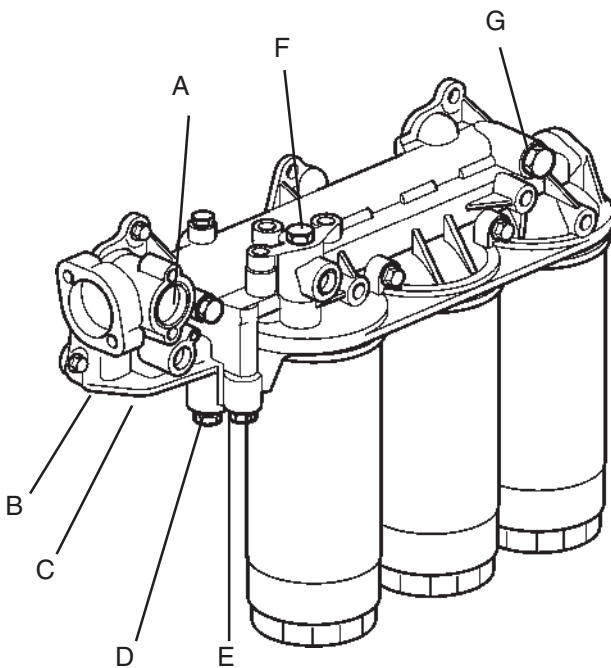

Overview, control valves

- A: Oil cooler bypass valve
- B: Safety valve
- C: Reduction valve
- D: Control valve for piston cooling
- E: Opening valve for piston cooling
- F: Bypass valve for bypass filter
- G: Bypass valve for full-flow filter

Pressure reduction valve, replacing

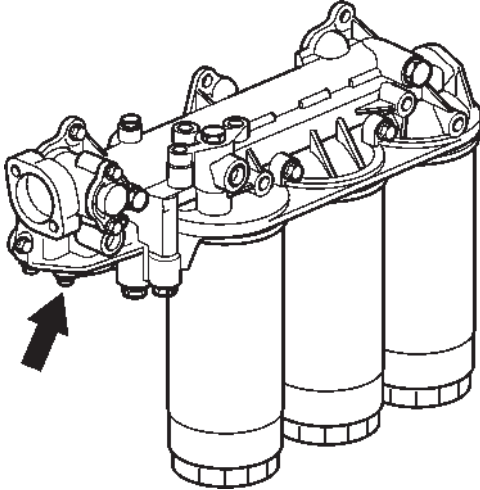

1. Clean the area around the reducing valve.
2. Remove the pressure reduction valve.
3. Clean the valve contact surface in the oil filter housing. Check that the old seal is not left.
4. Check that the color marking on the new valve matches the old.
5. Fit the new the valve with a new seal ring. Check that the internal seal does not come loose when the valve is installed.
Torque the screws as specified in "Technical data."
6. Start the engine and check for leaks.

Bypass valve oil filter, replacing

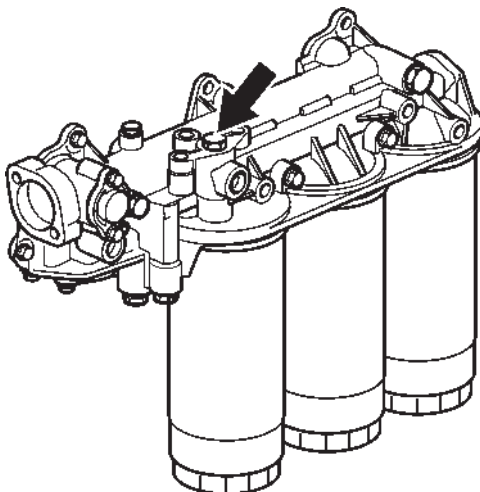

1. Remove the pressure pipe to the turbo.
2. Clean the area around the bypass valve.
3. Remove the bypass valve.
4. Clean the valve contact surface in the oil filter housing.
5. Fit the new valve with a new seal ring and torque the nut as specified in "Technical data."
6. Tighten the turbo pressure pipe.
7. Start the engine and check for leaks.

Oil pressure safety valve, replacing

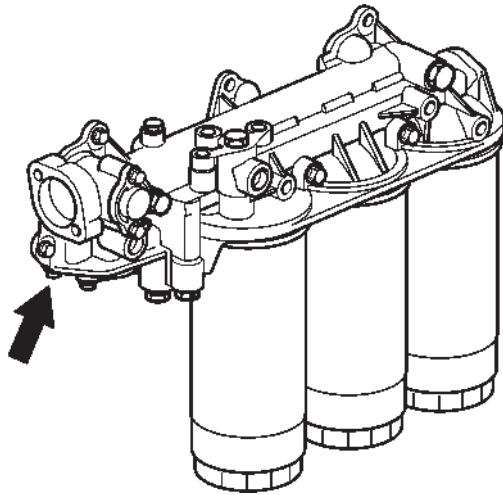

1. Clean the area around the valve and remove it.
2. Clean the valve contact surface.
3. Check that the color marking on the new valve matches the old.
Fit the new valve and torque as specified in "Technical data."
4. Start the engine and check for leaks.
Check the oil pressure, see "Oil pressure, checking"

Piston cooling valves, replacing

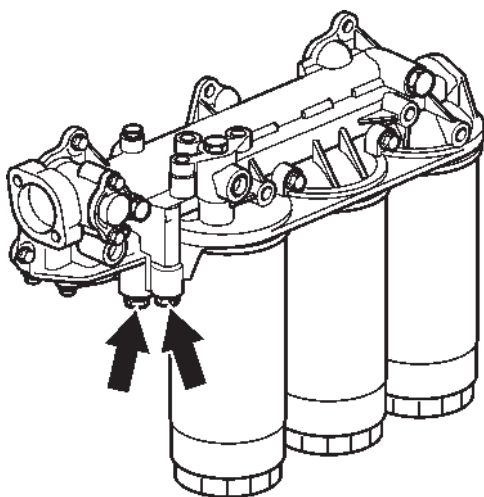

1. Clean around the oil filter bracket and the piston cooling valves.
2. Remove the filter bracket.
3. Remove the two piston cooling valves: control valve and opening valve.
4. Clean valve seats in the oil filter bracket.
5. Fit new valves with new seal ring, torque as specified in "Technical data."
6. Re-install the oil filter bracket, with new gasket and new sealing rings.
7. Start the engine and check for leaks.

Bypass valve oil filters, full flow, replacing

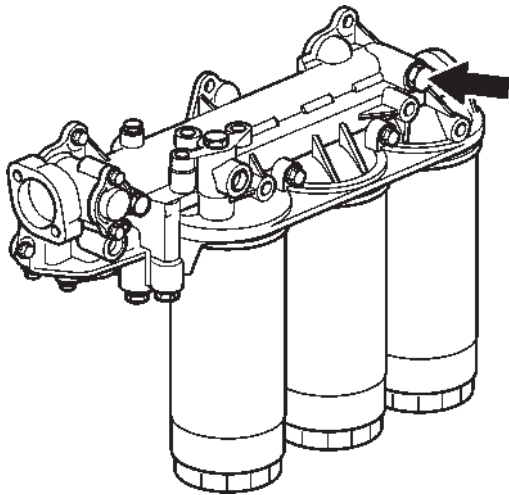

1. Clean the area around the bypass valve.
2. Remove the valve and clean the valve seat in the oil filter bracket.
3. Fit a new valve with a new seal ring.
Torque as specified in "Technical data."
4. Start the engine and check for leaks.

Oil filters, checking

1. Check that the oil filters are not faulty or blocked. If the filters have outside damage, oil flow through the filters may be prevented. This may cause the oil pressure to deteriorate.

Oil pressure sensor, checking

Special tools:

| | |
|----------------------|---------|
| Oil hose | 9998493 |
| Nipple | 9992873 |
| Pressure gauge | 9996398 |

If you suspect that the oil pressure sensor reads incorrectly, check the oil pressure with a external **pressure sensor**.

The pressure sensor is placed behind the control module, see "Placement of instrument socket" and "Sensor overview" in chapter "Troubleshooting / Tests and adjustments."

1. Check the oil pressure with an external pressure sensor and compare the values with specification in "Technical data."
2. Remove pressure sensor.
3. Install oil hose 9998493, nipple 9992873 and pressure gauge 9996398
4. Start the engine and check the oil pressure. If the oil pressure measurement shows that the pressure is below the minimum value as specified, continue troubleshooting by checking the oil filters.
If the oil pressure measurement using an external pressure sensor shows that the pressure is within tolerance, but the engine's regular pressure sensor does not, replace the pressure sensor.
5. Remove hose, nipple and pressure gauge.
6. Install the oil pressure sensor. Connect the sensor to the wiring.

Engine oil and oil filters, replacing 22231

Special tools:

Socket 9998487
Filter pliers 9999179

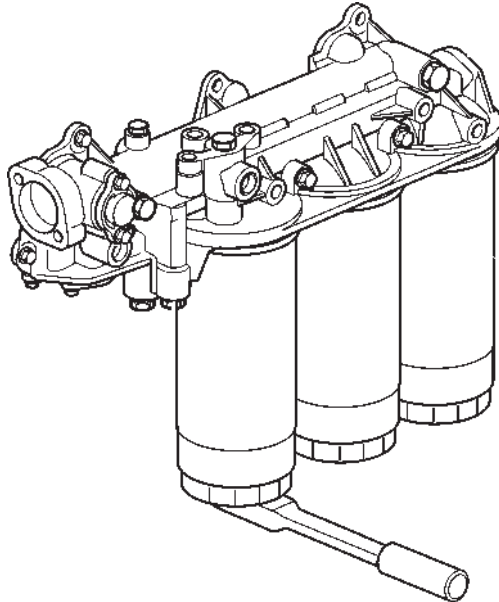

1. Remove the drain plug and drain engine oil into an appropriate container immediately after running when the oil is warm and flows more easily.

⚠ WARNING! Warm oil and hot surfaces can burn your skin!

2. Clean around the filter bracket and remove the filters. Use 9998487 or filter pliers.

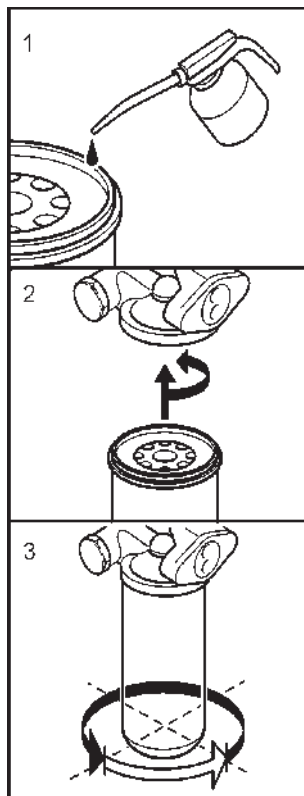

3. Fill the new the filters with engine oil and apply some to the gaskets (1).
 4. Tighten the filters by hand until they touch the bracket contact surface (2).
Tighten them by hand another **3/4 to one full turn** (3).
 5. Re-install the drain plug. Add engine oil to correct level.
 6. Connect a switch to the starter motor and use it to crank the engine until the oil pressure is registered by the oil pressure gauge. This means that the oil filters are full.
- NOTE:** See chapter "Troubleshooting / Tests and adjustments; Compression test" for connecting the starter motor.
7. Start the engine and check for any leakage around filter bracket and filter.
 8. Check oil level. Add oil as needed.

Pressure reduction valve, checking

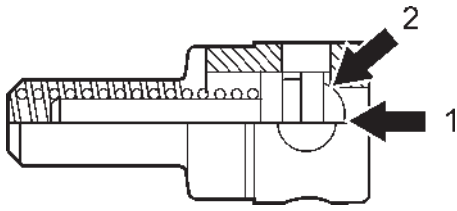

1. Check that the pressure reduction valve features a **blue** color marking.
2. Check that the valve is not damaged, which would hurt its function. Press in the valve cone (1) with a blunt object and check that it does not seize and that it seals against the seat (2).

Safety valve, checking

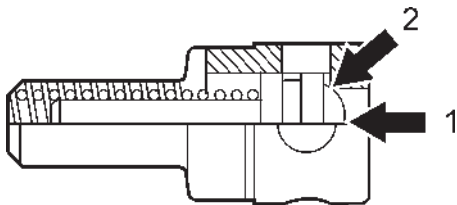

1. Check that the safety valve features a **purple** color marking.
2. Check that the valve is not damaged, which would hurt its function. Press in the valve cone (1) with a blunt object and check that it does not seize and that it seals against the seat (2).

Oil pump, replacing 22111

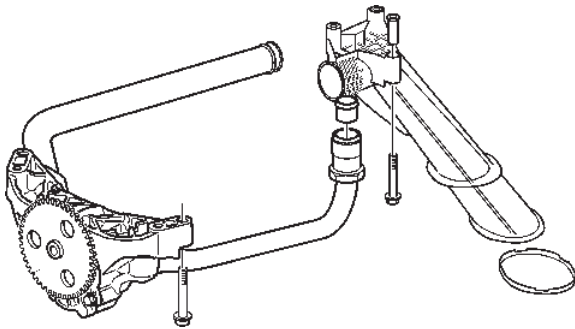

1. Drain engine oil.
Remove the oil filler pipe.
Remove terminal to the oil level sensor.
Remove the dip stick pipe from the bracket.
Remove the pan.
2. Remove screws that hold the oil pipes to the engine.
Remove the oil pipes, the oil strainer and the bracket together.
3. Remove the oil pump screws and remove the pump
4. Clean the oil suction pipe and the oil delivery pipe.
Check for damage.
5. Remove and clean the oil strainer. Check for damage.
6. Install the new oil pump.
Make sure that the plugs fit the camshaft drive
Torque the screws as specified in "Technical data."
7. Assemble the oil pipes and the oil strainer on the bracket with new oil seals. The strainer should be installed so that it points to the engine's front edge.
Torque the screws as specified in "Technical data."
8. Assemble the oil pipes with the oil pump.
Torque the screws as specified in "Technical data."
9. Check if the seal is needs to be replaced.
Fit the pan.
10. Attach the dipstick pipe to the bracket.
Install oil filler pipe and the cable harness to the oil level sensor.
Top up with engine oil.
11. Start the engine. Check the oil pressure and check for leakage.

Oil pump, checking

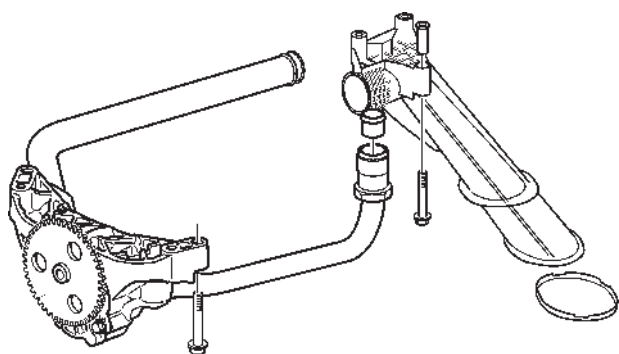

1. Remove the oil pump. See “Oil pump, replacing”
2. Check the pump drives.

NOTE: If the reason for the error can be traced to poor oil quality, clean the oil system thoroughly before new oil is filled.

Oil cooler

22311

Removal

1. Clean around the oil cooler casing.
2. Drain the coolant, see "Cooling system, draining"
Remove the coolant filter and its bracket.
3. Remove the casing screws and lift away the casing.
4. Remove the oil cooler from the engine block.

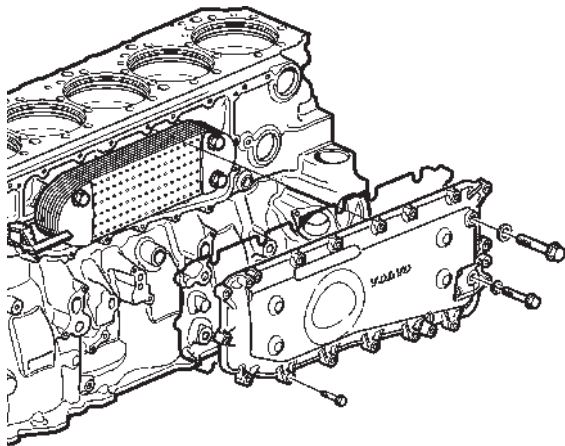

Fitting

1. Clean the casing contact surface on the engine block.
2. Install the oil cooler on the block with new rubber gaskets. Tighten screws as specified in "Technical data."
3. Install new gaskets in the casing.
4. Lift the casing into position. Check that the casing rubber gaskets does not get out of its groove.
5. Install casing screws and torque as specified in "Technical data."
Install the coolant filter and its bracket.
6. Add coolant. See Cooling system, filling and Cooling system, general.

NOTE: If the oil cooler has leaked engine oil to the cooling system, the coolant filter must be replaced and the cooling system cleaned. See cooling system, cleaning.

7. Start the engine and check for leakage when the it has reached normal temperature.
Check coolant level.

Oil cooler, leakage test

22312

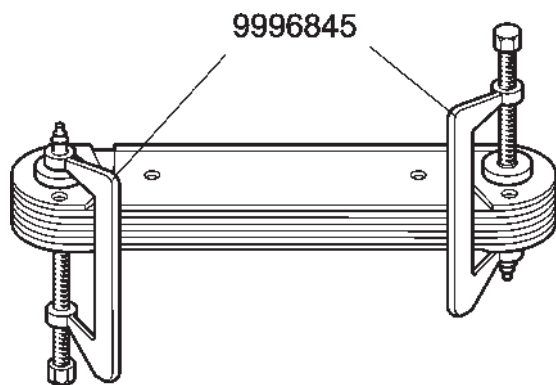

1. Remove the oil cooler. See "Oil cooler, removal/refitting."
2. Clean the oil cooler coolant fluid side with water soluble degreaser.
Clean the oil side of the oil cooler with degreaser.
3. Check the pressure testing device 9996662 before using it. See "Checking pressure testing device" in section "Cylinder head, pressure testing."
4. Install the screw clamps 9996845 and check that they are placed correctly.

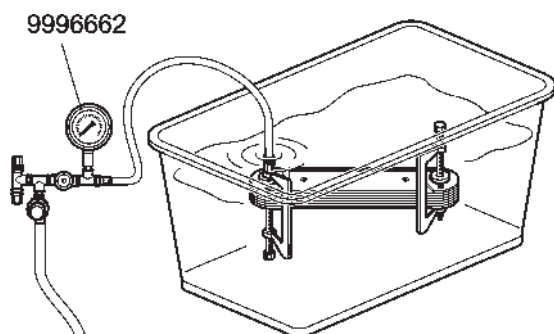

5. Check that the pressure reduction valve knob on the pressure testing device 9996662 is fully opened and that the pressure gauge shows "0."
Connect the pressure testing device to a screw clamp 9996845.
6. Lower the oil cooler into a container with water at room temperature.
Increase the pressure to 250 kPa (2,5 bar) with the pressure reduction valve knob.
Wait at least one minute.

NOTE: If an even stream of air bubbles come from the oil cooler element, it leaks and the oil cooler must be replaced.

Bypass valve oil cooler, replacing

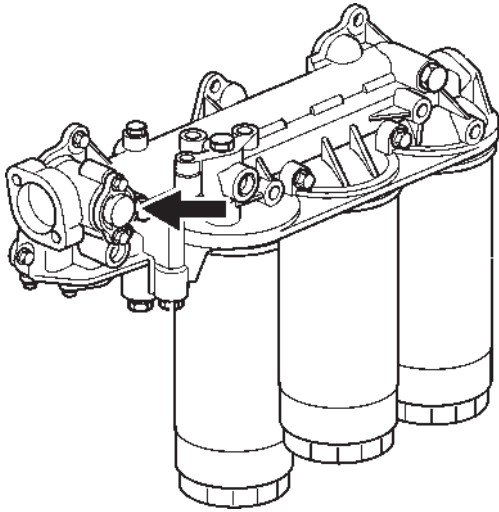

1. Clean the area around the bypass valve and remove it.
Clean the valve seat.
2. Fit the new valve with a new seal ring.
Torque as specified in "Technical data."
3. Start the engine and check for leaks.

Group 23: Fuel system

Draining, fuel channel in cylinder head

1. Clean around the fuel connections on the cylinder head and the fuel filter bracket.
2. Loosen the hose from the outlet on the fuel filter bracket and bend down the hose in a suitably vessel.
3. Remove the fuel return line at the front end of the cylinder head
4. Use a suitably hose and blow the fuel through the fuel channel in the cylinder head so that the fuel pours out in the vessel.

IMPORTANT! Be careful so that no dirt will come in to the fuel channel.

Control module, replacing

NOTE: Before the control module is replaced and any warranty claim made, all checks in the check list should be performed, to exclude any defect in engine control system. If the measurements of the flat cables show defects, it is highly likely that the control module is OK. See "Workshop Manual, EMS 2"

⚠ WARNING! Faulty individual adjustments of the control module may result in damage to people or the engine. For information about reprogramming and reading of software see "Workshop Manual, EMS 2"

⚠ WARNING! Exchange of control modules between engines, for troubleshooting or repair, must never be performed under any circumstances.

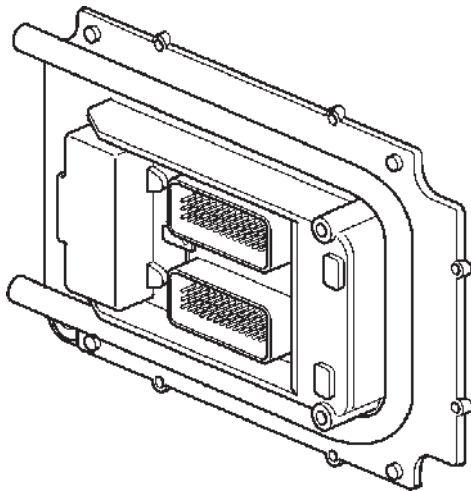

1. Clean thoroughly around the control module fuel connections.
2. Remove electricity from the engine by disconnecting the negative battery terminal.
3. Remove the lower part of the crankcase ventilation pipe.
4. Remove upper and lower cable harnesses clamps.
5. Remove the control module's cable harness by moving the connector block's retaining clips outwards.
6. Remove upper and lower fuel connections with the cooling element, plug the fuel lines.
7. Remove the screws that hold the control module and remove the control module.

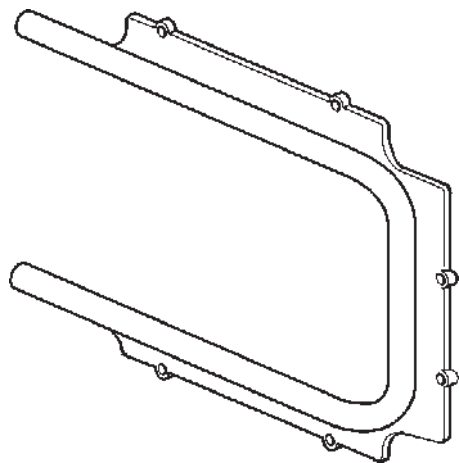

8. Transfer the cooling element to the new control module. Make sure that the surface between the cooling element and the control module is clean.
9. Install the new control module. Torque as specified in "Technical data."
10. Install upper and lower fuel connections to the cooling element with new sealing washers.
11. Install the cable harness and clamps.

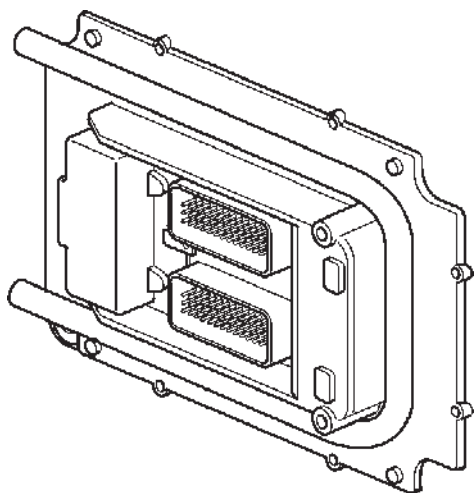

12. Install the lower crankcase ventilation pipe.
13. Vent the fuel system, see Fuel System, bleeding. Start the engine and check for error codes. See "Workshop Manual, EMS 2."

Fuel filters, replacing

23341

NOTE: Do not fill the new filter with fuel before installation. There is a risk that contamination enters the system and cause operational disturbances or damage.

⚠ WARNING! The fuel filter should be replaced when the engine is cold, to prevent any fire hazard if fuel is spilled on hot surfaces.

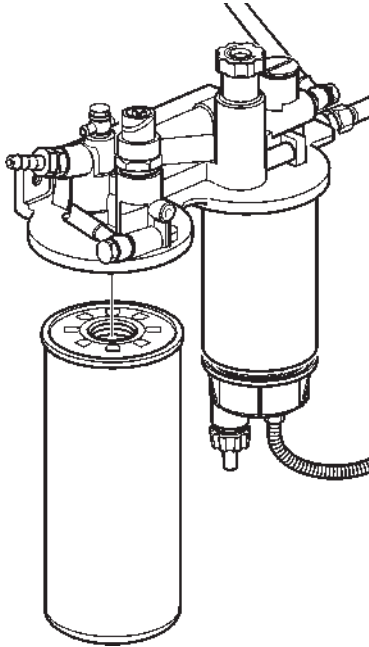

1. Clean around the fuel filter.
2. Remove the fuel filter. Use appropriate filter puller. Collect any spilled fuel in a container.
3. Clean around the filter housing sealing surface.
4. Lubricate the seal with diesel fuel and install the new fuel filter. Torque the filter per instructions on the filter.
5. Vent the fuel system, refer to "Fuel System, bleeding".

Primary fuel filter, change

23341

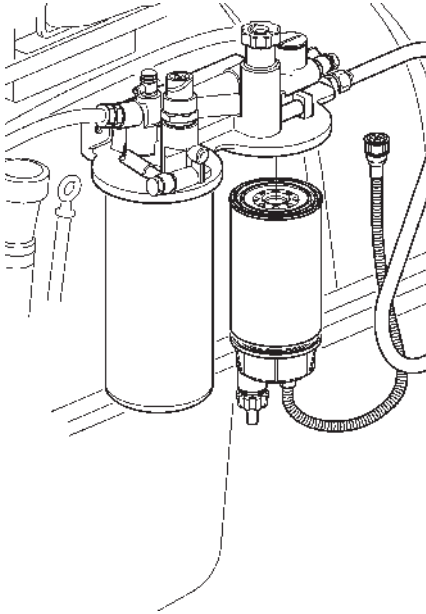

1. Disconnect cable harness at the water trap sensor.
2. Remove the water trap filter from the filter housing.
Collect any spilled fuel in a container.
3. Remove the lower part of the water trap from the filter.
4. Clean the water trap the bottom part with a soft rag. Check that the strainer and drain hole in the bottom part are not clogged.
5. Install a new seal on the lower part and lubricate the seal with diesel fuel.
Re-install the lower part of the filter.
6. Lubricate the seal with diesel fuel.
Screw the filter onto the filter bracket by hand until the rubber seal just touches the mating surface.
Then tighten a further half turn, no more.
7. Connect cable harness to the water trap sensor.
8. Vent the fuel system, refer to "Fuel System, bleeding" .

Fuel feed pump, replacing 23311

Removal

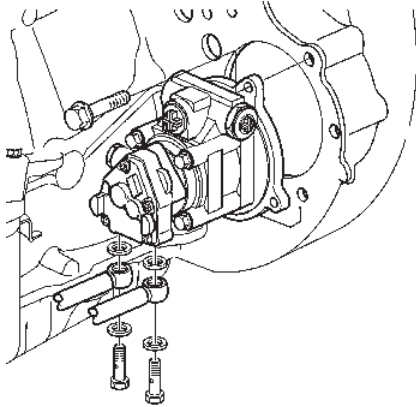

1. Close any fuel cocks between tank and feed pump, to avoid unnecessary fuel spills.
2. Remove fuel connections to the fuel pump and allow the fuel to flow out into a suitable container.
3. Clean thoroughly around the feed pump and its connections.
4. Place a suitable container under the feed pump and remove the fuel lines' banjo screws.

NOTE: Plug the lines! Note suction or pressure, respectively.

5. Remove the feed pump together with the servo pump.
6. Remove the feed pump from the servo pump, 3 torx screws.
7. Remove the feed pump by carefully pulling the pump straight out, making sure that the interconnection on the servo pump shaft does not come out with it.

Fitting

8. Replace o-ring on the servo pump flange and check that the interconnection fits in its groove on the servo pump shaft.
9. Install the feed pump on the servo pump, facilitate installation by turning the servo pump shaft so that it fits in its groove in the interconnection. Torque screws as specified.
10. Install feed pump/servo pump on the engine.
11. Replace the sealing washers, remove the plugs and install the fuel lines.
12. Open fuel cocks and bleed the fuel system. See "Fuel system, bleeding."
13. Start the engine and check for function and leakage.

Unit injector, replacing 23710

Special tools:

| | |
|-------------------------|---------|
| Puller | 9990006 |
| Slide hammer | 9990013 |
| Protective sleeve | 9998249 |
| Socket * | 9998580 |
| Handle* | 9807616 |

* included in cleaning kit 9998599

NOTE: If a new unit injector is fitted, a new injector code must be programmed into the control unit, see "Workshop manual EMS 2." The injector code is stamped on the unit injector

Installation

1. Remove the valve cover.
2. Remove electrical connections to the unit injectors. Cut off cable ties that hold the cable harness and fold it aside.
3. Remove the delivery pipe and the middle piece for the rocker bridge lubricating oil supply.
4. Remove the rocker bridge screws equally in stages so that the rocker arm shaft is not bent. Carefully lift the rocker bridge using tool 9990185.
5. Mark and remove the valve calipers.

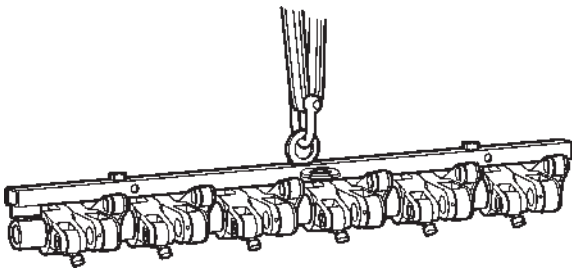

6. Empty the fuel channel in the cylinder head, see "Draining, fuel channel cylinder head" in chapter "Reconditioning / replacing components".
7. Remove the screws for the unit injector retainer. Place puller 9990006 on the injector. Place the puller fork in the groove on the injector and lock the arm with the screw on the side. Hold the puller by turning the screw down against the injector's ball cup. Fit a slide hammer 9990013 and remove the injector.
8. Place protective sleeve 9998249 on the injector that was removed.

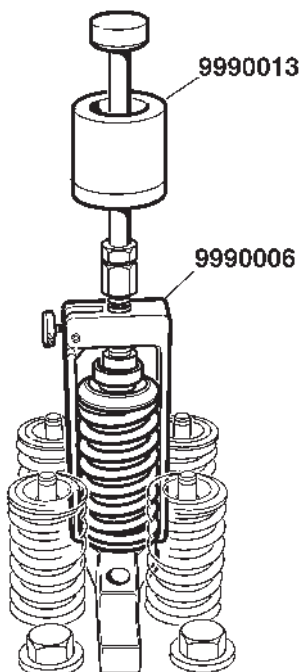

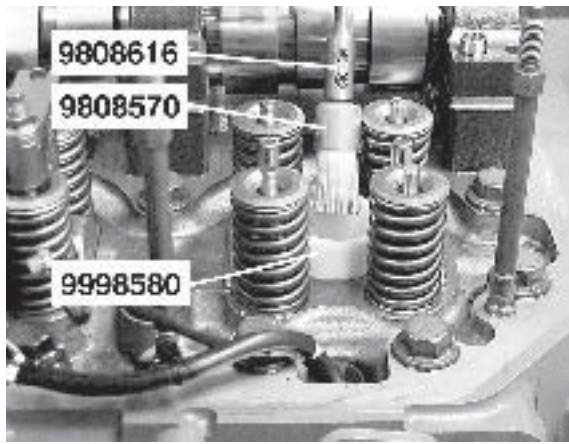

9. Install protective sleeve 9998580 and clean thoroughly with brush 9808570 and extender 9808616.

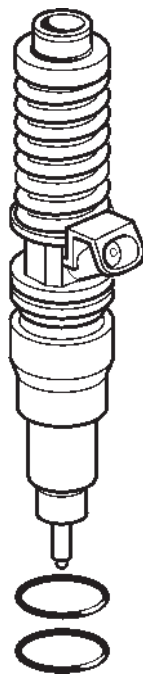

Fitting

10. Install new o-rings on unit injector.
Upper ring - large diameter
Lower ring - Small diameter

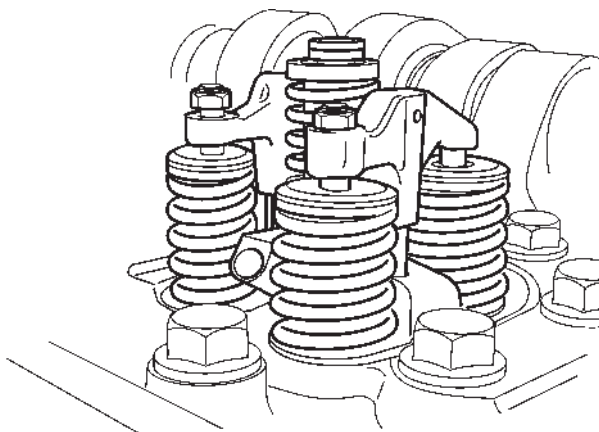

11. Install the retainer on unit injector and center it between the valve springs.
Torque the screw as specified in "Technical data."

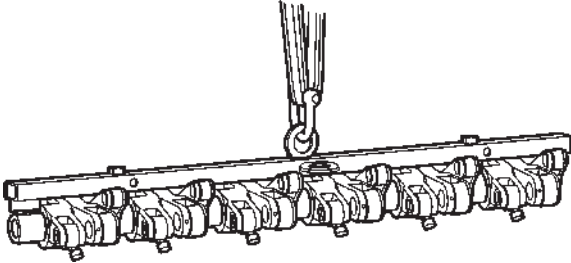

12. Connect the contact, press in until you hear a “click.”
Install new cable ties.
13. Install the valve calipers.
14. Oil valve calipers and cam shaft ridges with engine oil.
15. Lift the rocker bridge in place using lifting tool 9990185. Check that guide pins are positioned correctly in the bearing blocks.
Torque the rocker bridge screws as specified in “Technical data,” so that the shaft rests against the bearing blocks.

NOTE: Tighten alternately in order to prevent the rocker arm shaft from bending.

16. Clean the cylinder head at the place for the middle piece and check that there is no dirt in the cylinder head oil channel.
Fit new seal rings to the delivery pipe and middle piece. Apply a thin layer of petroleum jelly on the pipe sealing rings and install the pipe in the middle piece.
17. Install the piece in between and torque as specified in “Technical data.”
18. Adjust valves and unit injector, see “Valves and injectors, adjusting” in chapter “Engine body, general overhaul.”
19. Install the cable harness to the unit injectors and the valve cover.
20. Vent the fuel system. See “Fuel System, bleeding”

Venting the fuel system

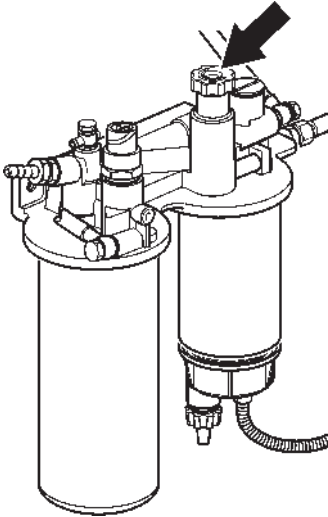

1. Check whether there is enough fuel in the tank, and that any fuel taps are open.
2. Remove the hand pump on the fuel filter bracket by turning it.
3. The fuel system is vented by pumping with the hand pump.
Air is vented to the tank via the fuel return pipe.
No venting nipples need to be opened.
4. Start the engine and let it idle fast for about 10 minutes.
5. Do a leakage and function check.

Group 25: Inlet and exhaust systems

Turbo, replacing

25512

Always determine and remedy the reasons why the turbocharger has been wrecked before a new turbocharger is installed.

One condition for the turbocharger to work satisfactorily is that the engine's lubrication and inlet systems are kept in good condition, i.e. that oil and filter changes are completed as scheduled, that the right kind of oil is used and that the air filter is managed correctly.

A first remedy should be checking the engine oil and replace the oil filters if needed, and preferably to run the engine a few minutes with the new oil before the new turbo unit is installed.

Blow out any rust- and soot flakes from the exhaust manifold when replacing turbocharger. The soot flakes could damage the turbine wheel of the new unit.

It is important to clean the intake line from the air cleaner as well. Parts from a wrecked compressor wheel may remain and cause an immediate wreck of the new turbo.

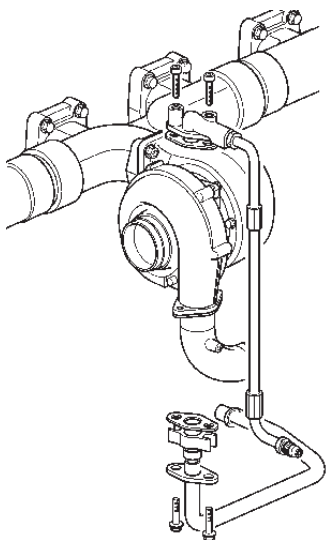

Removal

1. Remove the air hose between the turbo and the air filter housing.
2. Remove the screws and remove the exhaust pipe from the turbo.
3. Remove the oil delivery pipe and return oil pipe.
4. Remove the nuts and the spacer sleeves.
5. Remove the turbo.

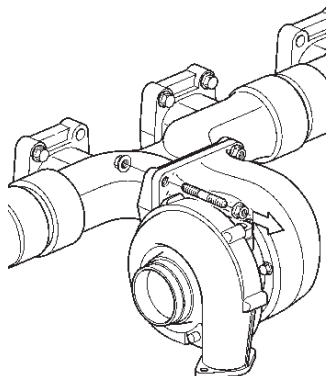

Fitting

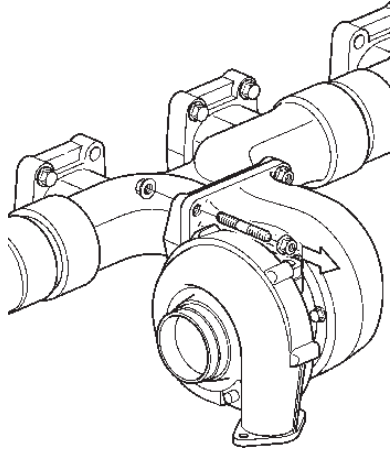

6. Clean the turbo contact surface on the exhaust manifold.
7. Fit the return oil pipe with a new seal ring against the engine block.
8. Place a new gasket on the exhaust manifold and install the turbo.
Torque nuts as specified in "Technical data."

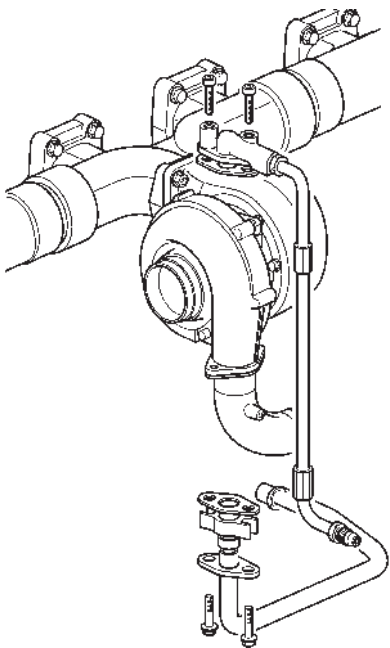

9. Connect return oil pipe using a new gasket against the turbo.
10. Fill the turbo with clean engine oil through the oil delivery pipe connection.
NOTE: Make sure no contaminants enter the connection. Use a strainer when filling oil.
11. Fit the oil delivery pipe with a new gasket.
12. Fit the exhaust pipe to the turbo.
13. Fit the hose between air filter and turbo.
14. Start the engine and check for leaks.

Group 26: Cooling system

Cooling system, draining

⚠ WARNING! Be careful when opening the coolant filler cap when the engine is hot. Steam or hot coolant can spray out.

NOTE: Before draining the cooling system, remove the expansion tank cover.

For engines to be mothballed or stored, the engine cooling system should not be drained. The coolant contains additives that protect against corrosion.

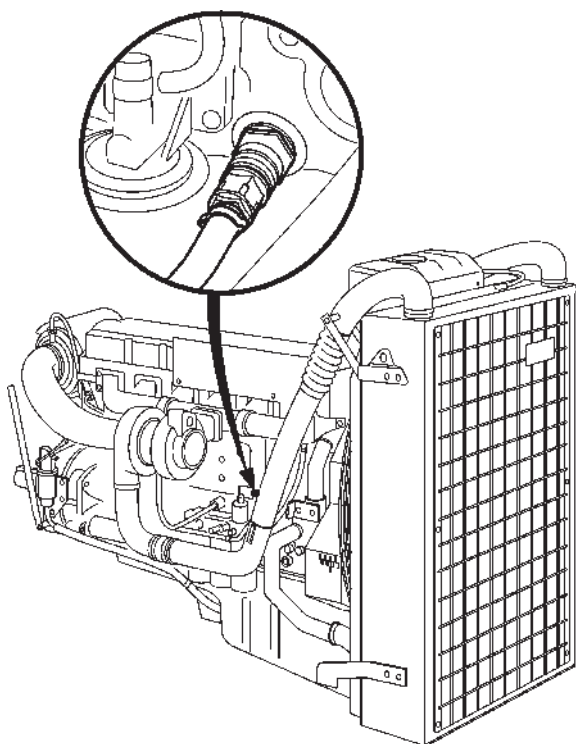

1. Open all drain points.
Drain the coolant from the radiator and the engine block with coolant drain tube 9996049. Drain nipples are located under the radiator and on the right-hand side of the block.
2. Check that all coolant drains out. Deposits may be found inside the drain plug/tap, and need to be cleared away. Otherwise, there is risk for coolant to remain standing, causing serious damage.
3. Close any cocks and check that the spring-loaded nipple covers close completely, install the rubber plugs.

Cooling system, cleaning

 **Warning!** Chemicals for the cooling system are a health hazard (do not ingest).

1. Empty the cooling system, see “Cooling system, draining,” and flush with clean water.
2. Close all open cocks and fill the cooling system with a mix of radiator cleaner and pure water. See instruction enclosed with cleaning kit.
3. Drain the cooling system again per the above and flush the system with a mix of neutralizer and pure water. See instruction enclosed with cleaning kit.
4. Add new coolant when the cooling system is completely free from contamination. See “Cooling system, general” and “Cooling system, filling.”

Cooling system, pressure-testing

Special tools:

Pressure-testing equipment... 885531

 **WARNING!** Be careful when opening the coolant filler cap when the engine is hot. Steam or hot coolant can spray out.

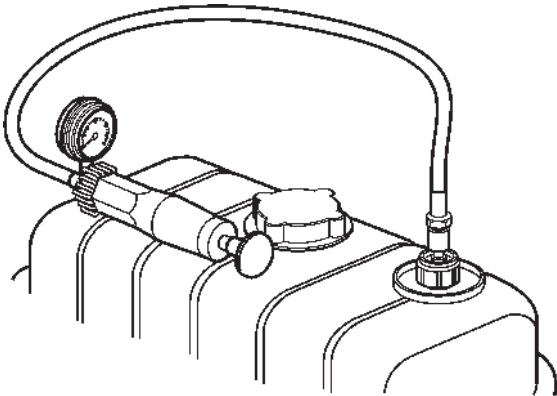

1. Check that all hoses are free from defects.
2. Check coolant level in the expansion tank.
3. Replace the coolant filler cap on the expansion tank with suitable tool from the kit 885531.
4. Pump up a pressure of 70 kPa (10 psi).
5. The pressure must not drop during a two minute test for the system to be considered to be free from leaks.
6. Vent excess pressure and remove pressure testing tool.
7. Check coolant level in the expansion tank. Install the regular coolant filler cap.
8. Start the engine and check for leaks.

Cooling system, filling

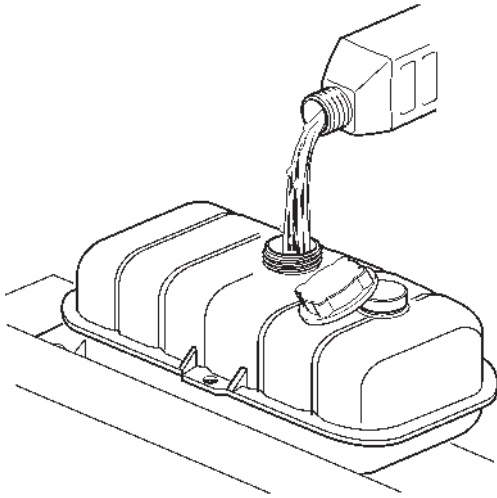

⚠ WARNING! Be careful when opening the coolant filler cap when the engine is hot. Steam or hot coolant can spray out.

NOTE: If a big volume of coolant must be filled, the system should be pressure tested, see "Cooling system, pressure-testing."

NOTE: When working on an engine where more a five liters (5.3 quarts) new coolant are being added, a new coolant filter should always be installed.

NOTE: Filling should be carried out with the engine stopped. Premix the right coolant volume so that you are sure the cooling system will be full. Filling must not be done so fast that an air lock is formed in the system. Air should be able to flow out through the fill opening and the vent cocks. Use only of Volvo Penta recommended coolant and mix.

NOTE: The engine must not be started until the system has been vented and completely filled.

1. Fill coolant to about 50 mm (2") under the coolant filler cap sealing surface.
2. Start the engine and let it run until it reaches normal operating temperature and the thermostat has opened.
3. Stop the engine, check coolant level and top up with coolant as needed.

Coolant pump, replacing 26211

Removal

⚠ IMPORTANT! Break the current or use some other means to prevent the engine from starting during the work.

1. Drain the coolant into a suitable container. see "Cooling system, draining"

2. Remove the drive belt shield that is installed above the coolant pump.

3. Remove the coolant pump drive belt by placing a pulling handle in the belt tensioner and ease the belt tension.
Remove the drive belt from the coolant pump.

4. Remove the coolant pump and its seal. Press the belt tensioner down so it is easier to access the lower screw in the coolant pump. Allow screw "1" to stay in the housing.

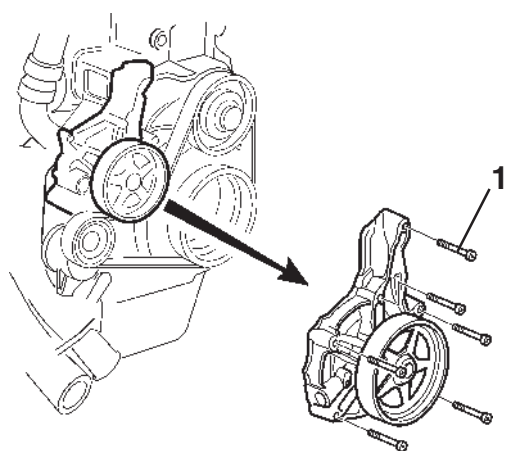

Fitting

5. Fit coolant pump with a new seal. Use petroleum jelly to hold the seal in place during installation. The screw "1" must be in place in the housing during installation. Torque the screws as specified in "Technical data"

6. Install the coolant pump drive belt.

7. Install the engine drive belt shield.

8. Add back the engine coolant, see "Cooling system, filling."

9. Start the engine and let it run until it reaches normal operating temperature.
Check that no leakage occurs. Top up with coolant as needed.

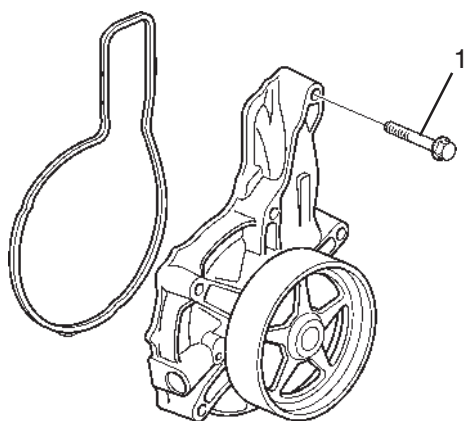

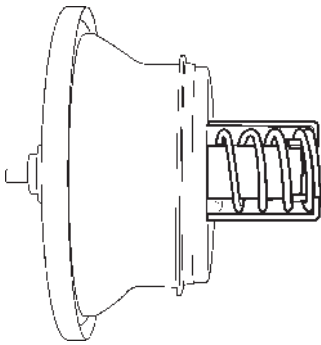

Closed thermostat

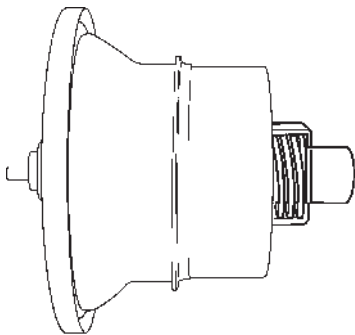

Open thermostat

Thermostat, functional check

26273

1. Remove the thermostat, see "Thermostat, replacing."
2. Place the thermostat in a big pot with water and heat it to the opening temperature as specified in "Technical data, Thermostat."
3. If the thermostat does not open at specified temperature, replace it.
4. Install the thermostat, see "Thermostat, replacing."

NOTE: Always use a new seal, even if the thermostat is not replaced.

Thermostat, replacing

26271

1. Drain the cooling system. See "Cooling system, draining."
2. Clean the area around the thermostat housing. Remove the radiator hose from the thermostat housing and unscrew it from the cylinder head.
3. Remove the thermostat and clean the inside of the housing.
4. Install a new thermostat and seal.
5. Torque the thermostat housing as specified in "Technical data."
Attach the radiator hose.
6. Refill the cooling system. See "Cooling system, filling."
7. Start the engine and check for leaks. Pressurize the cooling system to test it, see "Cooling system, pressure testing."

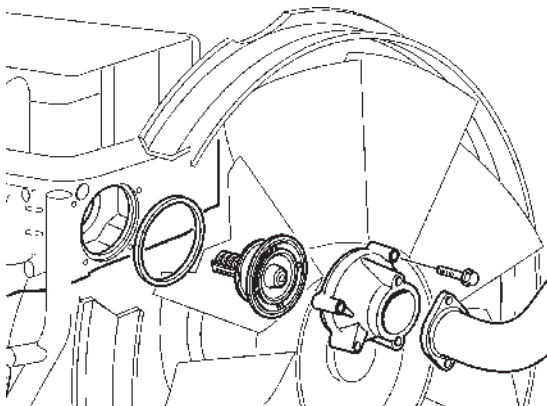

Coolant filter, changing

NOTE: The coolant filter should be replaced at stated intervals, if this is not done, the engine may last a lot less. When working on an engine where more a five liters (5.3 quarts) new coolant are being added, a new coolant filter should always be installed.

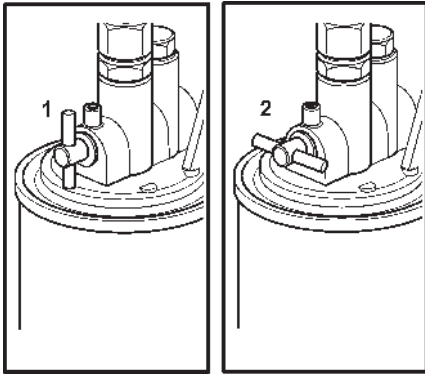

1. Tap open
2. Tap closed

1. Shut the filter housing valve.
2. Clean around the filter and remove it using filter pliers.

3. Lubricate the filter gasket with petroleum jelly, or soapy water, and fit the new filter. Screw the filter down until the gasket just touches the sealing surface. Then turn a further $\frac{1}{2}$ turn.
4. Open the cock on the filter housing.
5. Start the engine and check for leaks.

Drive belt/Alternator belt, inspection

Check belts after running when they are warm. You should be able to depress the alternator belt and the drive belt about 3-4 mm (0.118-0.158") between the pulleys.

Both the alternator belt and the drive belt has an automatic belt tensioner and need not be adjusted.

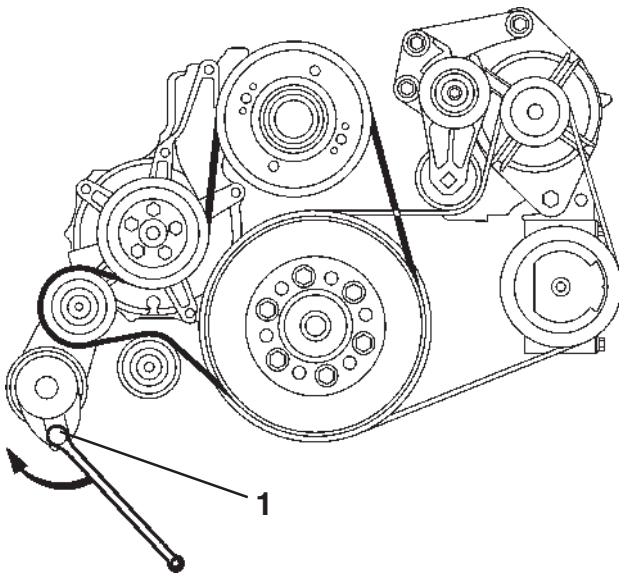

Drive belt, changing

1. Disconnect the main switch(es) and check that the engine is not connected to system voltage.
2. Remove the fan guard and fan ring round the cooling fan.
3. Remove the belt guard.
4. Place a 1/2" square wrench in the belt tensioner (1). Lift the wrench and remove the drive belt.
5. Thread the drive belt round the fan and remove it.
6. Check that the pulleys are clean and undamaged.
7. Thread the new drive belt over the fan.
8. Lift the 1/2" wrench and install the new drive belt.
9. Install the belt guards.
10. Install the fan guard and fan ring round the cooling fan.
11. Start the engine and do a function check.

Alternator belts, changing

⚠ IMPORTANT! Always replace a drive belt that seems worn or is cracked.

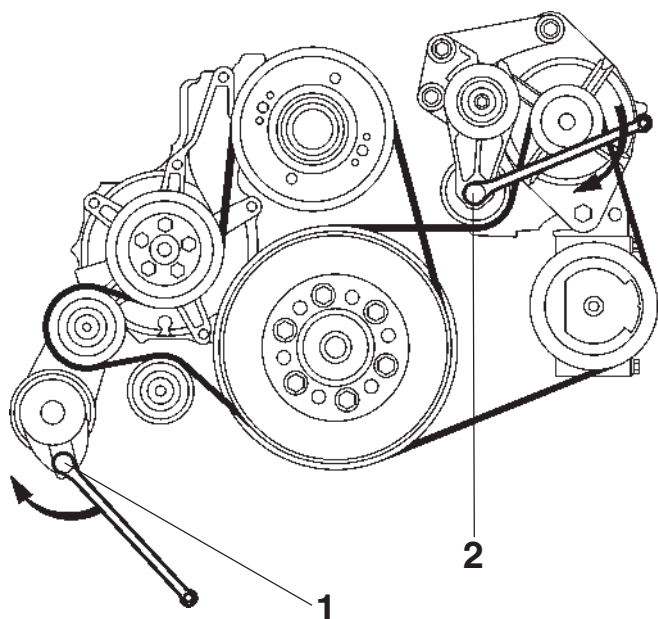

1. Disconnect the main switch(es) and check that the engine is not connected to system voltage.
2. Remove the belt guard.
3. Place a 1/2" square wrench in the belt tensioner (1). Lift the wrench up and lift off the water pump drive belt.
4. Place a 1/2" square wrench in the left belt tensioner (2). Press the wrench down and remove the alternator belt.
5. Check that the pulleys are clean and undamaged.
6. Press down the 1/2" spanner to the belt tensioner (2) and install the new alternator drive belt.
7. Lift the 1/2" spanner to the belt tensioner (2) and reinstall the water pump drive belt.
8. Install the belt guards.
9. Start the engine and do a function check.

Report form

Do you have any complaints or other comments about this manual. Please make a copy of this page, write your comments down and send them to us. The address is at the bottom. We would prefer you to write in English or Swedish.

From:
.....
.....
.....

Refers to publication:

Publication No.: Date of issue:

Proposal/motivation:
.....
.....
.....
.....
.....
.....
.....
.....
.....

Date:

Signed:

AB Volvo Penta
Technical Information
Dept. 42200
SE-405 08 Göteborg
Sweden

Workshop Manual

Group 23 EMS2

| |
|-------------|
| I |
| 4(0) |

**TAD1640GE, TAD1641GE, TAD1642GE
TAD1641VE, TAD1642VE**

EMS 2

TAD1640GE, TAD1641GE, TAD1642GE, TAD1641VE, TAD1642VE

Contents

| | | | |
|---|----|--|----|
| Safety Precautions | 2 | Service procedures | 27 |
| Introduction | 2 | When working with EMS 2 | 27 |
| General information | 5 | Control module (EMS 2), replace | 28 |
| About this Workshop Manual | 5 | Unit injector, replacing | 29 |
| Spare parts | 5 | Starting with auxiliary batteries | 30 |
| Certified engines | 5 | Function check | 31 |
| Service procedures | 6 | Diagnostic function for VODIA | 31 |
| Our joint responsibility | 6 | Fault tracing | 32 |
| Tightening torques | 6 | Symptoms and possible causes | 32 |
| Torque-angle tightening | 7 | Diagnostic function | 33 |
| Lock nuts | 7 | Malfunction message | 33 |
| Strength classes | 7 | Effect on engine | 33 |
| Sealant | 7 | Operation | 34 |
| General | 8 | Fault codes (EMS 2) | 36 |
| Location of engine signs | 8 | Electrical fault tracing | 46 |
| Tools | 9 | General | 46 |
| Special tools | 9 | Functional check of wiring and connector blocks | 46 |
| Technical data | 10 | Functional check of wiring and connector blocks | 47 |
| Design and function | 12 | Splicing cables for cable connectors | 48 |
| The EMS 2 system | 12 | Checking/fault tracing components | 49 |
| Component description, sensors and monitors ... | 15 | Electrical system | 57 |
| Control module (EMS 2) | 18 | Important information - electrical system | 57 |
| Control Interface Unit (CIU) | 18 | Electrical system, overview | 68 |
| Unit injector | 19 | Wiring diagram EMS 2 | 60 |
| Alternator | 19 | Wiring diagram CIU | 61 |
| Starter | 19 | Wiring diagram DCU | 62 |
| Component location | 20 | | |
| Limit values | 21 | | |
| Limit values, control module (EMS 2) | | | |
| TAD1640–1642GE | 21 | | |
| Limit values, control module (EMS 2) | | | |
| TAD1641–1642VE | 23 | | |
| Limp-Home function | 26 | | |

Safety information

Introduction

This workshop manual contains descriptions and repair instructions for the Volvo Penta products or product versions noted in the table of contents. This workshop manual should be used together with the workshop manual **Technical data** for the engine in question. Check that you have the correct Workshop Manual for your engine.

Read the appropriate safety precautions with care as well as **General information** and **Service procedures** before starting work.

Important

In this book and on the engine you will find the following special warning symbols.

 **WARNING!** Possible danger of personal injury, extensive damage to property or serious mechanical malfunction if the instructions are not followed.

 **IMPORTANT!** Used to draw your attention to something that can cause damage or malfunctions on a product or damage to property.

NOTE: Used to draw your attention to important information that will facilitate the work or operation in progress.

To give you a perspective on the risks which always need to be observed and precautions which always have to be taken, we have noted them below.

 Immobilize the engine by turning off the power supply to the engine at the main switch (switches) and lock it (them) turned off before starting work. Set up a warning notice at the engine control point.

 All service work should normally be done on a stationary engine. Some tasks, such as adjustments, need the engine running, however. Approaching an engine which is operating is a safety hazard. Remember that loose clothing or long hair can fasten in rotating parts and cause serious personal injury.

 If work is done adjacent to a running engine, a careless movement or a dropped tool can lead to personal injury in the worst case. Be careful with hot surfaces (exhaust pipes, turbos, charge air pipes, starting heaters etc.) and hot fluids in pipes and hoses on an engine which is running or which has just stopped.. Reinstall all guards removed during service operations before starting the engine.

 Check that the warning or information labels on the product are always clearly visible. Replace labels which have been damaged or painted over.

 Never start the engine without installing the air cleaner filter. The rotating compressor turbine in the turbocharger can cause severe injury. Foreign objects entering the intake ducts can also cause mechanical damage.

 Never use start spray or similar products as a starting aid. They may cause an explosion in the inlet manifold. Danger of personal injury.







 Only start the engine in a well-ventilated area. When operated in a confined space, exhaust fumes and crankcase gases must be ventilated from the engine bay or workshop area.

 Avoid opening the coolant filling cap when the engine is hot. Steam or hot coolant can spray out and the system pressure will be lost. When needed, open the filler cap slowly and release the pressure in the system. Be very careful if a stopcock or plug or engine coolant hose must be removed when the engine is hot. It is difficult to anticipate in which direction steam or hot coolant can spray out.

 Hot oil can cause burns. Avoid skin contact with hot oil. Ensure that the lubrication system is not under pressure before carrying out any work. Never start or operate the engine with the oil filler cap removed, otherwise oil could be ejected.

 Stop the engine before carrying out operations on the engine cooling system.

- ⚠ If extra equipment is installed on the engine which alters its center of gravity a special lifting device is required to obtain the correct balance for safe handling.
- ⚠ Never carry out work on an engine that is **only** suspended in a hoist.
- ⚠ Never work alone when heavy components are to be dismantled, even when safe lifting devices such as lockable blocks & tackle are used. When using a lifting device two people are usually required to do the work, one to take care of the lifting device and another to ensure that components are lifted clear and not damaged during the lifting operations.
- ⚠ Always check before starting work if there is enough room to carry out removal work without risking personal injury or damage to the engine or parts.
- ⚠ **WARNING!** The components in the electrical system and in the fuel system on Volvo Penta products are designed and manufactured to minimize the risk of fire and explosion. The engine must not be run in areas where there are explosive materials.
- ⚠ Only use the fuels recommended by Volvo Penta. Refer to the Instruction Book. Use of fuels that are of a lower quality can damage the engine. On a diesel engine poor quality fuel can cause the engine to over-rev with resulting risk of damage to the engine and personal injury. Poor fuel can also lead to higher service costs.
- ⚠ Remember the following when washing with a high pressure washer: Never direct the water jet at seals, rubber hoses, electrical components or the radiator.
- ⚠ Always use protective glasses or goggles when carrying out work where there is a risk of splinters, grinding sparks, acid splashes or where other chemicals are used. Your eyes are extremely sensitive, injury could cause blindness!
- ⚠ Avoid getting oil on your skin! Repeated exposure to oil or exposure over a long period can result in the skin being damaged. Irritation, dryness and eczema and other skin problems can then occur. Used oil is more dangerous than fresh oil from a health aspect. Use protective gloves and avoid oil soaked clothes and shop rags. Wash regularly, especially before eating. There are special skin creams which counteract drying out of the skin and make it easier to clean off dirt after work is completed.
- ⚠ Most chemicals intended for the product e.g. engine and transmission oils, glycol, petrol (gasoline) and diesel oil, or chemicals for workshop use e.g. degreasers, paints and solvents are hazardous. Read the instructions on the product packaging with care! Always follow the safety precautions for the product, i.e. use of protective mask, glasses, gloves etc. Make sure that other personnel are not inadvertently exposed to hazardous chemicals, for example in the air. Ensure good ventilation in the work place. Follow the instructions provided when disposing of used or leftover chemicals.
- ⚠ Exercise extreme care when leak detecting on the fuel system and testing the fuel injector nozzles. Use eye protection. The jet which comes from a fuel injector has very high pressure and considerable penetration power. Fuel can force its way deep into body tissue and cause severe injury. Danger of blood poisoning (septicemia).
- ⚠ All fuels and many chemical substances are flammable. Do not allow naked flame or sparks in the vicinity. Petrol (gasoline), some thinners and hydrogen gas from batteries are extremely flammable and explosive when mixed with air in the correct ratio. No Smoking! Ensure that the work area is well ventilated and take the necessary safety precautions before starting welding or grinding work. Always ensure that there are fire extinguishers at hand when work is being carried out.
- ⚠ Ensure that rags soaked in oil or fuel and used fuel or oil filters are properly taken care of. Rags soaked in oil can spontaneously ignite under certain circumstances. Used fuel and oil filters are polluting waste and must be handed to an approved waste management facility for destruction, together with used lubrication oil, contaminated fuel, paint residue, solvents, degreasers and wash residue.
- ⚠ Never expose a battery to naked flame or electrical sparks. Never smoke close to the batteries. The batteries generate hydrogen gas when charged, which forms an explosive gas when mixed with air. This gas is easily ignited and highly explosive. A spark, which can be formed if the batteries are wrongly connected, is enough to make a battery explode and cause damage. Do not shift the connections when attempting to start the engine (spark risk) and do not lean over any of the batteries.

-  Always ensure that the Plus (positive) and Minus (negative) battery cables are correctly installed on the corresponding terminal posts on the batteries. Incorrect installation can result in serious damage to the electrical equipment. Refer to the wiring diagram.
 -  Always use protective goggles when charging and handling the batteries. Battery electrolyte contains sulfuric acid which is highly corrosive. Should the battery electrolyte come into contact with unprotected skin wash off immediately using plenty of water and soap. If battery acid comes in contact with the eyes, immediately flush with plenty of water and obtain medical assistance at once.
 -  Turn the engine off and turn off the power at the main switch(es) before carrying out work on the electrical system.
 -  The clutch must be adjusted with the engine shut off.
 -  Use the lifting eyes fitted on the engine when lifting the drive unit. Always check that the lifting equipment used is in good condition and has the load capacity to lift the engine (engine weight including gearbox, if fitted, and any extra equipment installed).
 -  Use an adjustable lifting beam or lifting beam specifically for the engine to raise the engine to ensure safe handling and to avoid damaging engine parts installed on the top of the engine. All chains and cables should run parallel to each other and as perpendicular as possible in relation to the top of the engine.
-

General information

About this Workshop Manual

This Workshop Manual contains descriptions and instructions for the repair of standard versions of engines: TAD1640GE, TAD1641GE, TAD1642GE, TAD1641VE, TAD1642VE.

The workshop manual can illustrate tasks done on any of the engines noted above. This means that the illustrations and photographs which clarify certain details might, in some cases, not correspond with other engines. Repair methods are similar in all important respects, however. The Engine Designation and Engine Numbers can be found on the product plate. See "Technical data TAD1640GE, TAD1641GE, TAD1642GE, TAD1641VE, TAD1642VE".

Please always include both the engine designation and the engine serial number in all correspondence.

The Workshop Manual is produced primarily for the use of Volvo Penta workshops and service technicians. For this reason the manual presupposes a certain basic knowledge and that the user can carry out the mechanical/electrical work described to a general standard of engineering competence.

Volvo Penta constantly improves its products, so we reserve the right to make modifications without prior notification. All information in this manual is based on product data which was available up to the date on which the manual was printed. Any material changes introduced into the product or service methods after this date are notified by means of Service Bulletins.

Spare parts

Spare parts for the electrical and fuel systems are subject to various national safety requirements. Volvo Penta Original Spare Parts meet these specifications. Any type of damage which is the result of using spare parts that are not original Volvo Penta parts for the product in question will not be covered under any warranty or guarantee provided by AB Volvo Penta.

Certified engines

The manufacturer warrants that both new and currently operating engines that are certified to national and regional environmental regulations meet environmental requirements. The product must correspond to the engine that was approved during certification. The following requirements for service and spare parts must be complied with, for Volvo Penta as a manufacturer to be responsible for ensuring that engines in use comply with the stipulated environmental requirements:

- Service and maintenance intervals recommended by Volvo Penta must be followed.
- Only Volvo Penta Original Spare Parts intended for the certified engine version may be used.
- Service work that covers injection pumps, pump settings, and injectors must always be carried out by an authorized Volvo Penta workshop.
- The engine must not be converted or modified in any way, except for the accessories and service kits which Volvo Penta has approved for the engine.
- Any seals on the engine may not be broken by unauthorized persons.



IMPORTANT! When spare parts are needed, use only Volvo Penta Original Spares.

Use of non-original parts will result in AB Volvo Penta being unable to warrant that the engine corresponds to the certificated engine version.

Any damage, injury and/or costs which arise due to the use of non-original Volvo Penta spares for the product in question will not be compensated by Volvo Penta.

Repair instructions

The working methods described in the Workshop Manual apply to work carried out in a workshop. The engine has been removed and is installed in an engine fixture. Unless otherwise stated reconditioning work which can be carried out with the engine in place follows the same working method.

See chapter "Safety information" where the meaning of the warning signs used in the manual are explained in detail.



WARNING!



IMPORTANT!

NOTE:

are not comprehensive in any way, since we can not of course foresee everything, because service work is done in highly varying circumstances. For this reason, all we can do is to point out the risks which we believe could occur due to incorrect work in a well-equipped workshop, using work methods and tools tested by us.

All operations described in the Workshop Manual for which there are Volvo Penta Special Tools available assume that these tools are used when carrying out the repair. Volvo Penta Special Tools have been specifically developed to ensure the most safe and rational working methods possible. It is therefore the responsibility of anyone using other tools or other working methods than we recommend to determine that there is no risk of personal injury or mechanical damage or malfunction as a result.

In some cases special safety precautions and user instructions may be required in order to use the tools and chemicals mentioned in the Workshop Manual. These rules must always be observed, so there are no special instructions about this in the workshop manual.

By following these basic recommendations and using common sense it is possible to avoid most of the risks involved in the work. A clean work place and a clean engine will eliminate many risks of personal injury and engine malfunction.

Especially when working on the fuel system, engine lubrication system, air intake system, turbocharger unit, bearing seals and seals, it is extremely important to avoid dirt or foreign objects entering the parts or systems, since this can result in reduced service life or malfunctions.

Our common responsibility

Each engine consists of a large number of collaborating systems and components. Any deviation of a component from its technical specification can dramatically increase the environmental impact of an otherwise good engine. For this reason, it is extremely important that specified wear tolerances are maintained, that systems with adjustment facilities are correctly adjusted and that Volvo Penta Original Spares are used for the engine. The stated service intervals in the Maintenance Schedule must be observed.

Some systems, such as the components in the fuel system, require special expertise and special testing equipment for service and maintenance. Some components are sealed at the factory, for environmental reasons etc. Under no circumstances attempt to service or repair a sealed component unless the service technician carrying out the work is authorized to do so.

Remember that most chemical products, incorrectly used, damage the environment. Volvo Penta recommends the use of bio-degradable degreasing agents for all cleaning of engine components unless otherwise stated in the Workshop Manual. Pay special attention to make sure that oils and washing residue etc are handled correctly for destruction, and do not unintentionally end up in nature.

Torque

The tightening torques for critical joints, which should be tightened with a torque wrench, are listed in Technical data, "Tightening Torques", and are noted in the task descriptions in the manual. All torque specifications apply to clean screws, screw heads and mating faces. Torque data stated apply to lightly oiled or dry threads. Where grease, locking or sealing agents are required for screwed joints this is stated in both the operation description and in "Tightening Torques". Where no torque is stated for a joint use the general torque shown in the following table. The torques stated are a guide and the joint does not have to be tightened using a torque wrench.

| Dimension | Tightening torque | |
|-----------|-------------------|---------|
| | Nm | lbf.ft. |
| M5 | 6 | 4.4 |
| M6 | 10 | 7.4 |
| M8 | 25 | 18.4 |
| M10 | 50 | 36.9 |
| M12 | 80 | 59.0 |
| M14 | 140 | 103.3 |

Torque-angle tightening

In torque/angle tightening, the fastener is tightened to the specified torque, and tightening then continues through a pre-determined angle. Example: for 90° angle tightening, the joint is turned a further 1/4 turn in one sequence, after the specified tightening torque has been achieved.

Lock nuts

Disassembled locknuts shall not be re-used, they shall be replaced by new ones, since the locking properties are impaired or lost when the nut is used several times. For lock nuts with a plastic insert such as Nylock® the torque stated in the table is reduced if the Nylock® nut has the same head height as a standard hexagonal nut without plastic insert. Reduce the torque by 25% for screw size 8 mm or larger. Where Nylock® nuts are higher, where the metallic thread is of the same height as a standard hexagonal nut, the torques given in the as shown in table apply.

Strength classes

Screws and nuts are sub-divided into different strength classes. The classification is shown by a marking on the screw head. Markings of a higher number indicate stronger material. For example, a screw marked 10-9 is stronger than one marked 8-8. For this reason, it is important when fasteners are dismantled, that the screws are put back in the correct places when they are re-installed. If a bolt must be replaced check in the spare parts catalogue to make sure the correct type is used.

Sealant

Several types of sealant and locking liquid are used on the engines. The properties of the sealants differ as they are intended for different strengths of fastenings, temperature, resistance to oil and other chemicals, and also for different materials and gap thicknesses found in the engine.

To ensure service work is correctly carried out it is important that the correct sealant and locking fluid type is used on the joint where the agents are required.

In this Volvo Penta Workshop Manual the user will find that each section where these agents are applied in production states which type was used on the engine.

For service work, an similar product from the same manufacturer, or corresponding product with the same characteristics from another manufacturer, can be used.

When using sealants and locking fluids, make sure that mating surfaces are dry and free from oil, grease, paint, anti-corrosion agent and old sealant. Always follow the manufacturer's instructions for use regarding temperature range, curing time and any other instructions for the product

Two different basic types of agent are used on the engine. These are:

1. RTV agent (Room Temperature Vulcanizing). Used for gaskets, sealing gasket joints or coating gaskets. RTV is visible when a part has been disassembled; old RTV must be removed before resealing the joint.

The following agents are of RTV-type: Loctite® 574, Volvo Penta 840879-1, Permatex® No. 3, Volvo Penta 1161099-5, Permatex® No 77. Old sealant can be removed using denatured alcohol in all cases.

2. Anaerobic agents. These agents cure in the absence of air. These agents are used when two solid components, i.e. cast components, are fitted together without a gasket. Common uses are also to lock and seal plugs, stud threads, taps, oil pressure monitors etc. Hardened anaerobic preparations are glassy and for this reason, the preparations are colored to make them visible. Cured anaerobic agents are extremely resistant to solvents and the old agent cannot be removed. When reinstalling the part, degrease it carefully and then apply new sealant.

The following agents are anaerobic: Loctite® 572 (white), Loctite® 241 (blue).

Notice: Loctite® is a registered trademark for the Loctite Corporation.

Permatex® is a registered trademark for the Permatex Corporation.

General

Location of engine signs

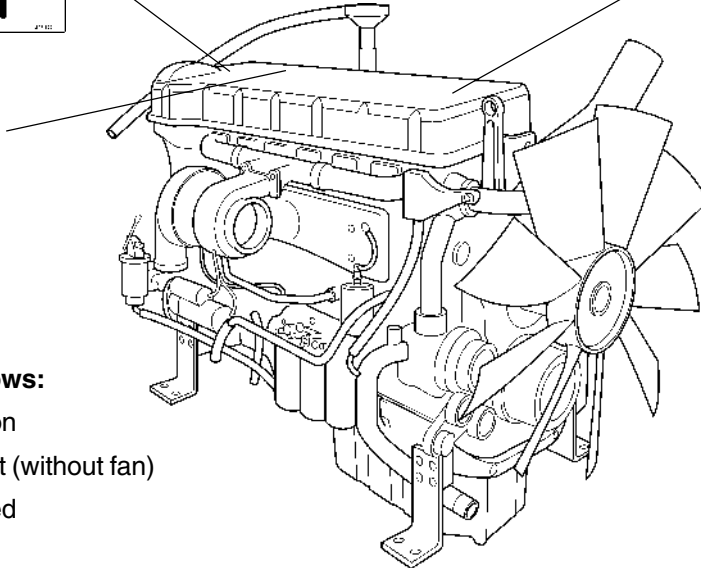
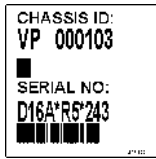

The sign above shows:

- 1 Engine designation
- 2 Serial number
- 3 Specification number

The sign above shows:

- A Engine designation
- B Engine power, net (without fan)
- C Max. engine speed
- D Main software
- E Data set 1
- F Data set 2
- G Product number

Explanation of engine designation:

E.g. TAD1641GE/TAD1641VE

- T – Turbo
- A – Air to air intercooler
- D – Diesel engine
- 16 – Cylinder volume, liter
- 4 – Generation
- 1 – Version
- G – Generator unit engine
- V – Stationary and mobile operation
- E – Emission certified

Tools

Special tools

The following special tools are used when working on the engine. The special tools can be ordered from AB Volvo Penta by specifying the number shown.

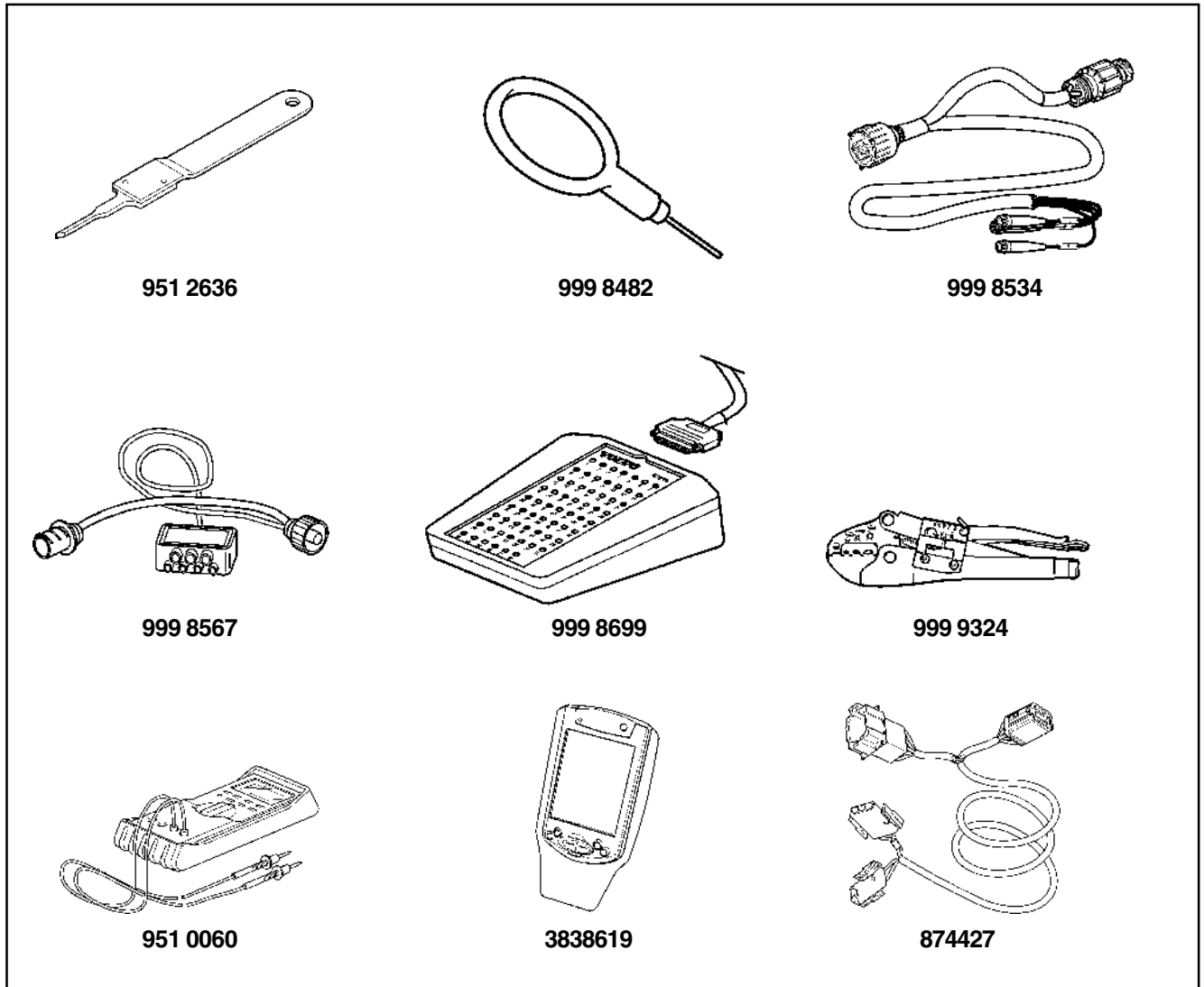

| Tool | Designation – use | | |
|-----------------|-----------------------------|-----------------|--|
| 951 2636 | Pin tool, connector | 999 9324 | Cable lug crimper, repair |
| 999 8482 | Gauge, connector block | 951 0060 | Multimeter, fault tracing/checking |
| 999 8534 | 4-pin adapter, diagnostics | 1078054 | Repair kit (not shown in figure) |
| 999 8567 | 7-pin adapter, diagnostics | 3838619 | VODIA, complete with cable harness. See "VODIA User's Guide" for ordering separate parts. |
| 999 8699 | 62-pin adapter, diagnostics | 874427 | Nozzle diagnostic output |

Technical data

Control unit

| | |
|---------------------------------|----------------------------------|
| Voltage | 24 V |
| Connector | 2 x 62-pin |
| Working temperature range | -40°C to +90°C (-40°F to +194°F) |
| Cooling | External fuel cooling |

Sensor, water in fuel

| | |
|----------------------|------------------------------|
| Voltage | 24 V |
| Connector | 2-pin |
| Connector type | Closing in presence of water |

Sensor, fuel pressure

| | |
|------------------------------|----------------------------------|
| Voltage | 5 V |
| Connector | 3-pin |
| Working pressure range | 0–700 kPa (0–101.5 Psi) |
| Pressure signal | 0,5–4.5 V |
| Type | Linear |
| Max tightening torque | 30 ± 5 Nm (22.13 ± 3.688 lbf ft) |

Camshaft sensor/flywheel sensor

| | |
|---------------------------------|-----------------------------------|
| Inductive sensor | |
| Connector | 2-pin |
| Working temperature range | -40°C to +120°C (-40°F to +248°F) |
| Type | Inductive sensor |
| Max tightening torque | 8 ± 2 Nm (5.9 ± 1.475 lbf ft) |

Sensor, oil pressure

| | |
|----------------------------------|-------------------------|
| Voltage | 5 V |
| Connector | 4-pin |
| Working pressure range | 0–700 kPa (0–101.5 Psi) |
| Pressure signal | 0,5–4.5 V |
| Working temperature range: | -40°C till +140°C |
| Type | Linear |

Combined sensor, oil level/oil temperature

| | |
|---------------------------------|-----------------------------------|
| Connector | 4-pin |
| Working temperature range | -40°C to +140°C (-40°F to +284°F) |
| Contact type | Resistive/NTC |
| Max tightening torque | 7 Nm (5.2 lbf-ft) |

Combination sensor, charge air pressure/charge air temperature

| | |
|---------------------------------|-------------------------------------|
| Voltage | 5 V |
| Connector | 4-pin |
| Working pressure range | 40–400 Pa (5.8–58 Psi) |
| Pressure signal | 0.3–4.8 V |
| Working temperature range | -40°C till +130°C (-40°F to +266°F) |
| Type | Linear/NTC |
| Max tightening torque | 4.5 Nm (33.1 lbf-ft) |

Sensor, coolant temperature

| | |
|---------------------------------|-----------------------------------|
| Voltage | 5 V |
| Connector | 2-pin |
| Working temperature range | -40°C to +140°C (-40°F to +284°F) |
| Type | NTC |
| Max tightening torque | 20-24 Nm (14.75 - 17.7 lbf-ft) |

Sensor, coolant level

| | |
|--------------------|--------------------------------|
| Connector | 2-pin |
| Contact type | Closing with low coolant level |

Sensor, crankcase pressure

| | |
|------------------------------|----------------------------------|
| Voltage | 5 V |
| Connector | 3-pin |
| Working pressure range | 0–700 kPa (0–101.5 Psi) |
| Pressure signal | 0,5–4.5 V |
| Type | Linear |
| Max tightening torque | 30 ± 5 Nm (22.13 ± 3.688 lbf ft) |

Sensor, piston coolant pressure

| | |
|-----------------------------|-------------------------------------|
| Voltage | 24 V |
| Connector | 2-pin |
| Pressure signal | At 150 kPa ±20 kPa (21.76 ±2.9 psi) |
| Type | Two-position (NC) |
| Max tightening torque | 30 ± 5 Nm (22.13 ± 3.688 lbf ft) |

Combined air filter pressure and temperature sensor

| | |
|---------------------------------|---------------------------------------|
| Voltage | 24 V |
| Connector | 4-pin |
| Pressure signal | At 5 kPa ±0.5 kPa (0.725 ±0.0725 Psi) |
| Working temperature range | -40°C till +130°C (-40°F to +266°F) |
| Type | Linear/Two-position (NC) |

Unit injector

| | |
|--------------------------|---------------------|
| Voltage | 90 V |
| Connector | 2-pin |
| Injection pressure | 180 kPa (26.11 Psi) |

Alternator

| | |
|-----------------|-----------------------|
| Voltage | 24 V |
| Connector | 2-pin |
| Capacity | 80 A (110 A optional) |

Starter

| | |
|-----------------|-------|
| Voltage | 24 V |
| Connector | 2-pin |
| Capacity | 7 kW |

Design and function

The EMS 2-system

EMS 2 stands for "Engine Management System" and is an electronic system with CAN communications (Controller Area Network) for control of diesel engines. The system has been developed by Volvo Penta and includes fuel control and diagnostic function. The system consists of a control module, six unit injectors, a number of sensors that supply the control module with measurements, sockets for diagnosis and functional checks. The engine is connected to a communications interface consisting of a CAN link and a serial link.

CAN (Controller Area Network)

The CAN J1939 link handles all communications between the engine control module EMS 2 and a communications interface such as the CIU or DCU, in addition to the diagnostics that are handled by the so called J1708/J1587 link. The CAN link is much faster than the J1708/J1587 link. The CAN link has been prepared to connect to other components with SAE J1939 protocol such as instrument panels and transmissions.

If, for some reason, a fault develops on the CAN link, signals for the rpm-potentiometer and the start and stop knobs are taken over by the J1708/J1587 link. However, instrument and indicator lamps are completely turned off. If faults develop on both links, the GE engines maintain the same rpm while VE engines slow to idle. The only way to shut off the engine in this case is to use the auxiliary stop (AUX-STOP) placed on the engine's left side.

CIU (Control Interface Unit)

The CIU is a "translator" between the CAN bus and the customer's own control panel. This unit has two serial communication links, one fast and one slow. The fast one is a CAN link that features a bus speed of 250 Kbit/s. All data regarding instruments, indicator lamps, contacts and potentiometers are controlled by this bus. The slower J1708/J1587 link handles diagnostic information for, among other things, the flashing code. The diagnosis tool VODIA also uses the J1708/J1587 link to communicate with the system.



DCU (Display Control Unit)

DCU is a digital instrument panel that communicates with the engine control module via the CAN link. DCU has several functions, such as:

Controlling the engine

- Start, stop, controlling rpm, control mode isochronous/speed drop, pre-heating.

Monitoring

- rpm, charge pressure, charge temperature, coolant temperature, oil pressure, oil temperature, engine hours, battery voltage, instantaneous fuel consumption and fuel consumption (trip fuel).

Diagnostics

- Shows fault codes as text. Lists previous faults.

Setting parameters

- Idling speed, pre-heating when ignition on, lamp test, alarm limit for oil temperature/coolant temperature, control mode, control gradient (VE), primary engine rpm (GE), speed drop (GE), engine overspeed limit (GE), engine cut off, overspeed (GE).

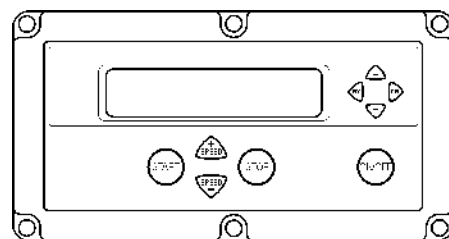

DU (Display Unit)

DU is an instrument that displays the engine's operating values. Measurement values are shown graphically on an LCD screen. The display communicates via the CAN link and consists of a computerized unit for fixed installation in a control panel.

You are connected to the CAN link between the engine control module and CIU or DCU.

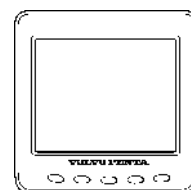

Input signals

The control module receives input signals about the engines operating conditions and other things from the following components:

- coolant temperature sensor
- charge pressure / charge temperature sensor
- crankcase pressure sensor
- position sensor, camshaft
- speed sensor, flywheel
- piston cooling pressure sensor
- coolant level sensor
- oil pressure sensor
- oil level sensor and oil temperature sensor
- fuel pressure sensor
- water in fuel indicator
- air filter pressure
- air temperature sensor

Output signals

Based on the input signals the control module controls the following components:

- the unit injectors
- starter motor
- alternator
- main relay
- pre-heating relay

The information from the sensors give exact data about prevailing operating conditions and allows the processor in the control module to, among other things, calculate correct injection amount, injection timing and check the engine's condition.

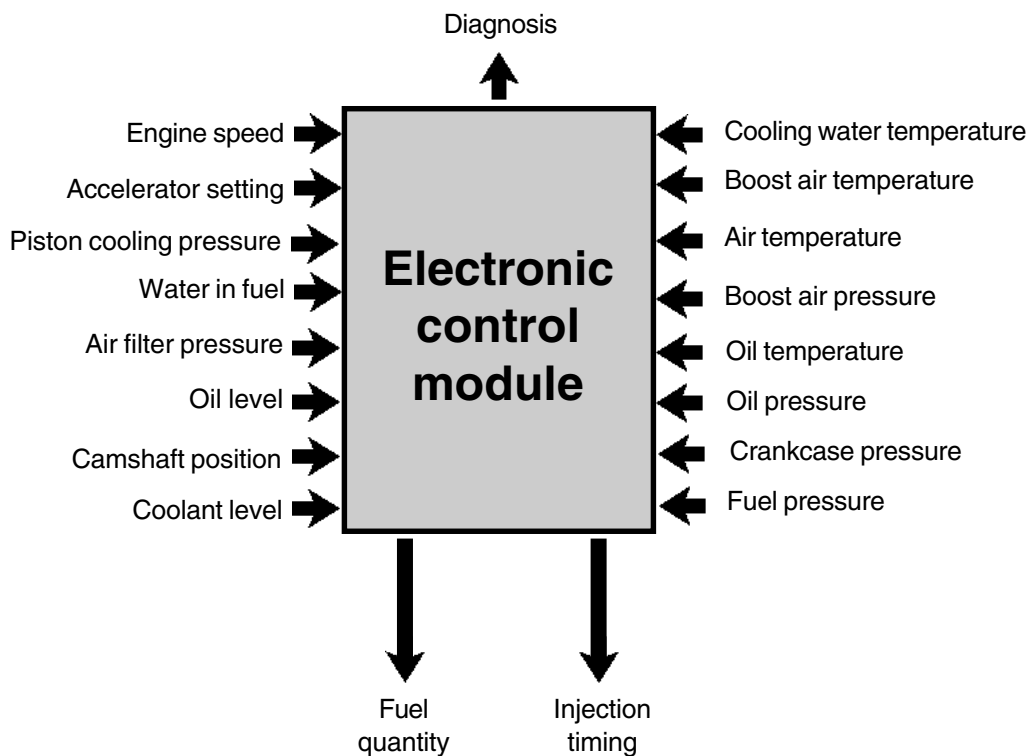

Fuel control

The engine's fuel requirement is analyzed up to 100 times per second (depending on engine rpm). The engine's injection amount and injection timing is controlled electronically via fuel valves on the unit injectors.

This means that the engine always receives the correct volume of fuel in all operating conditions, which offers lower fuel consumption, minimal exhaust emissions etc.

The control module checks and controls the unit injectors so that the correct amount of fuel is injected into each cylinder. It calculates and sets the injection angle. The control is primarily performed using the speed sensors and the combined sensor for boost pressure/charge air temperature.

The control module affects the unit injectors via an electronic signal to the unit injectors' electromagnetic fuel valve, which can open and close.

When the fuel valve is open, fuel flows past, through the unit injectors' holes and continuing out through the fuel channel. Fuel is not sprayed into the cylinder in this position.

When the fuel valve closes, pressure starts to build from the unit injector's mechanically operated pump plunger. When sufficient pressure has developed, fuel is injected into the cylinder via the unit injector's injector section.

The fuel valve is re-opened and pressure in the unit injector decreases at the same time as the fuel injection to the cylinder stops.

In order to determine when the fuel valve shall open or close, the control module has access to signals from sensors and switch contacts.

Calculating amount of fuel

The amount of fuel that is sprayed into a cylinder is calculated by the control module. The calculation determines the time that the fuel valve is closed (when the fuel valve is closed fuel is sprayed into the cylinder). The parameters controlling injected amount of fuel are:

- Rpm requested
- Engine protector functions
- Temperature
- Charge air pressure

Cylinder balancing

When idling, the control module can supply the cylinder with different amounts of fuel. This so the engine will have a more even idle. At higher rpm, this problem does not exist, and the cylinders receive the same amount of fuel.

Altitude correction

The control module is equipped with an atmospheric air pressure sensor and altitude correction function for engines that operate at a high altitude. This function limits amount of fuel depending on ambient air pressure. The control module is equipped with an atmospheric air pressure sensor and altitude correction function for engines that operate at a high altitude. This is to prevent smoke, high exhaust temperature and to protect the turbocharger from over-speeding.

Diagnostic function

The task of the diagnosis function is to detect and locate disturbances within the EMS 2 system, to protect the engine, and to provide information about problems that have developed.

If a malfunction is discovered, this is announced by warning lamps, a flashing diagnostic lamp or in plain language on the instrument panel, depending on the equipment used. If a fault code is obtained as a flashing code or in plain language, this is used for guidance in any troubleshooting. Fault codes can also be read by Volvo's VODIA tool at authorized Volvo Penta workshops.

In case of serious disturbances, the engine is shut down completely or the control module reduces the available power (depending on the application). Once again, a fault code is set for guidance in any troubleshooting.

Component description

The numbers after the heading refer to "component location" on page. 20.

Sensor, water in fuel (11)

The sensor is located in the lower part of the fuel pre-filter.

It's purpose is to detect water in the fuel system. The sensor comprises two copper electrodes, between which the resistance is measured. When the resistance drops below a certain limit, which indicates that there is water in the fuel, a warning message is sent to the control unit.



Position sensor, camshaft (15)

The position sensor is located in the upper timing gear cover. The camshaft position sensor is of the inductive-sensor type. The sensor reads off a cogged wheel with 7 cogs. The impulses from the camshaft sensor give the control unit information about which cylinder is in turn for injection and when it is performed.

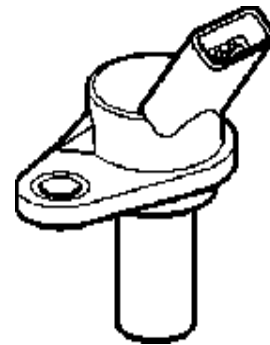

Oil pressure sensor (9)

The oil pressure and temperature are measured by a combined sensor located on the left side of the engine, next to the control unit.

The sensor is fitted in the engine block so that measurements are performed in the lubrication systems main oil galley. The pressure signal is a voltage signal proportional to the pressure. The sensor reference voltage is 5 Volts.



Speed sensor, flywheel (18)

The sensor is located in the left side of the flywheel housing.

The flywheel speed sensor is of the inductive type. It reads off the crankshaft position and speed from grooves in the flywheel. The signal is sent to the control unit, which calculates injection timing and fuel quantity.

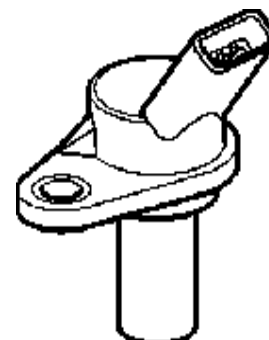

Charge air pressure/charge air sensor (3)

The charge air pressure and temperature are measured via a combined sensor positioned on the inlet pipe.

The charge air pressure sensor measures absolute pressure, which is the sum of charge air pressure and atmospheric pressure. The sensor supplies the control unit with a voltage signal proportional to the absolute pressure. The sensor receives a reference signal of 5 Volts from the control unit.

The charge air temperature sensor comprises a non-linear resistor, where the resistance is dependant on the temperature of the resistor body. The resistance drops as temperature rises.



Coolant temperature sensor (16)

The sensor is located in the left rear part of the cylinder head.

The sensor senses the coolant temperature and sends the information to the control unit. The sensor comprises a non-linear resistor, where the resistance is dependant on the temperature of the resistor body. The resistance drops as temperature rises.



Fuel pressure sensor (10)

The sensor is located on the left side of the engine, mounted on the fuel filter bracket.

The pressure signal is a voltage signal proportional to the pressure. The sensor reference voltage is 5 Volts.

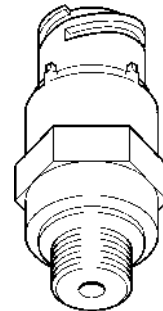

Coolant level sensor (1)

The sensor is located in the expansion tank.

It's purpose is to detect if the coolant level in the cooling system (expansion tank) becomes too low. The sensor is a magnetically sensitive switch. A float located around the sensor affects the switch differently depending on the coolant level. A alarm signal is sent when the coolant level is too low.

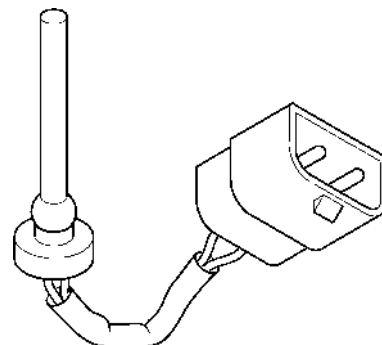

Oil level sensor / oil temperature sensor (12)

The sensor is located in the oil sump.

The purpose of the level sensor is to detect if the oil level becomes too low. A current is passed through the sensor and the voltage measured across it is then proportional to the oil level. A alarm signal is sent when the oil level is too low. The temperature sensor consists of a non-linear resistor, where the resistance is dependent on the temperature of the resistor body. The resistance drops as temperature rises.

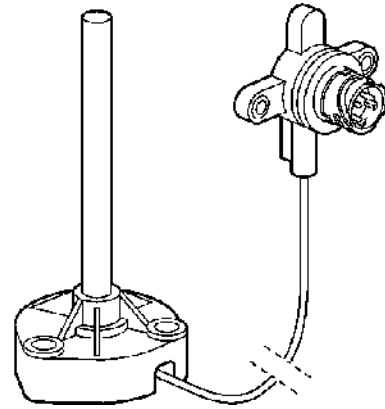

Crankcase pressure sensor (13)

The sensor is located on top of the engine in the middle of the valve cover on the engine's left side.

The pressure signal is a voltage signal proportional to the pressure. The sensor reference voltage is 5 Volts.

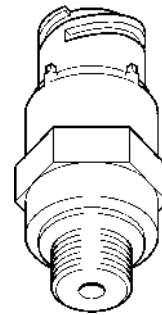

Piston cooling pressure sensor (17)

The monitor is installed on the engine block below the turbo on the right side of the engine.

The pressure signal is a voltage signal proportional to the pressure. The sensor reference voltage is 5 Volts.

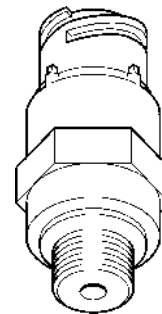

Air filter pressure sensor / air filter temperature sensor (4)

Air filter pressure and air filter temperature are measured by a combined sensor placed above the air filter.

The air filter pressure sensor measures absolute pressure, the sum of air filter pressure and atmospheric pressure. The sensor consists of a monitor that sends a signal to the control module when the pressure in the air filter becomes too high.

The air filter temperature sensor consists of a non-linear resistor, where the resistance is dependant on the temperature of the resistor body. The resistance drops as temperature rises.

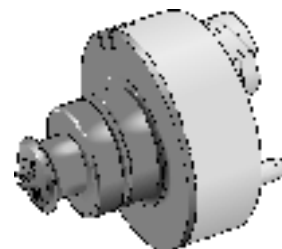

Control module EMS 2

The control module checks and controls the unit injectors so that the correct amount of fuel is injected into each cylinder. It calculates and sets the injection angle. The control is primarily performed using the speed sensors and the combined sensor for boost pressure/charge air temperature.

The EMS 2 system processor is located in the control unit, where it is protected from moisture and vibration.

The processor receives information continuously about:

- engine speed
- camshaft position
- charge air pressure
- charge air temperature
- coolant temperature
- oil pressure
- oil temperature
- oil level
- crankcase pressure
- piston cooling pressure
- water in fuel
- fuel pressure
- coolant level
- air filter pressure
- air filter temperature

Information from the sensors provides exact information about current operation conditions and allows the processor to calculate the correct fuel volume, check engine status etc.

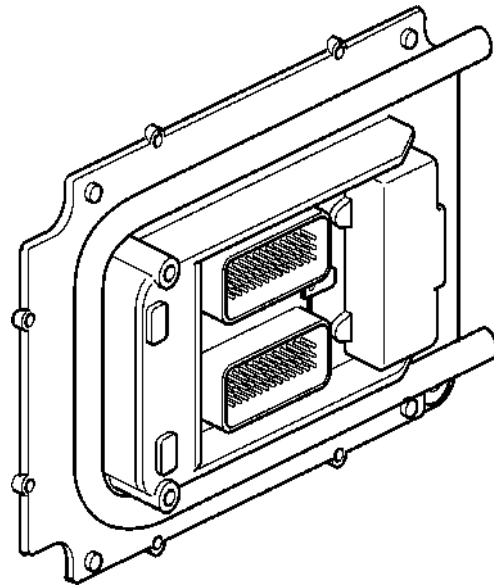

Control Interface Unit (CIU)

CIU is a control unit that handles all interactions with the operator.

It communicates with the engine via two serial communication buses. J1939 is used for control and monitoring of the engine. J1587 is used for diagnostics and backup.

The CIU unit reads in the status of a number of switches as well as the engine speed request and forwards them to the engine. It also controls the four analog instruments and up to nine warning lamps. By using the diagnostic button and a diagnostic lamp, the driver can read off fault codes from the system.

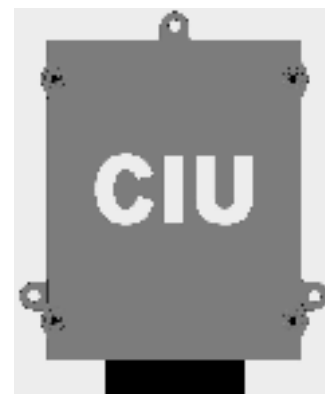

Unit injector

The unit injectors are located under the valve cover, mounted in the cylinder head.

The engine's fuel requirement is analyzed up to 100 times per second (depending on engine rpm). The amount of fuel injected into the engine and the injection timing are electronically controlled via the unit injector's solenoid controlled fuel valves. This means that the engine always receives the correct volume of fuel in all operating conditions, which offers lower fuel consumption, minimal exhaust emissions etc.

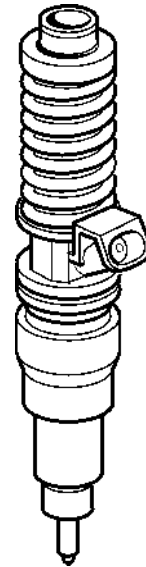

Alternator

The alternator is belt driven and is located at the left front of the engine.

The alternator's voltage regulator is equipped with a sensor system. The sensor system compares the charging voltage between the alternator's B+ and B- terminals, with the voltage between the battery's positive and negative poles. The voltage regulator then compensates the voltage drop in the cables between the alternator and battery by increasing the charging voltage at the alternator, if necessary.

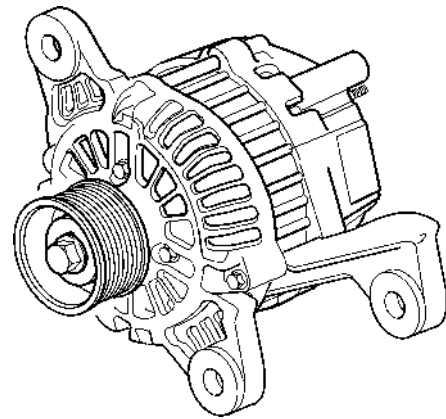

Starter

The starter is mounted on the flywheel housing on the engine's right side.

During starting, a gear on the starter rotor shaft is moved axially so that it engages with the ring gear on the engine's flywheel. The axial movement as well as the activation of the starter is controlled by a solenoid on the starter motor.

The starter solenoid in turn is connected via the starter relay, which is activated when the starter key is turned to position III/the starter button is pressed.

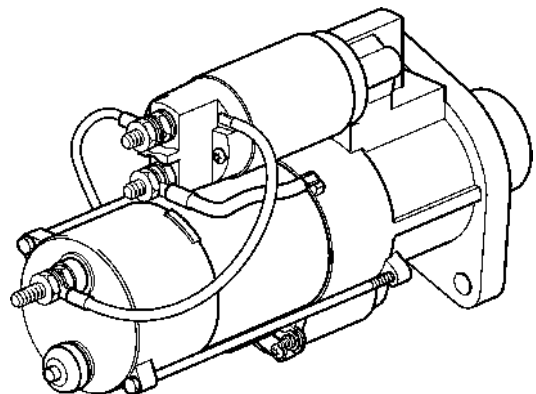

Component location

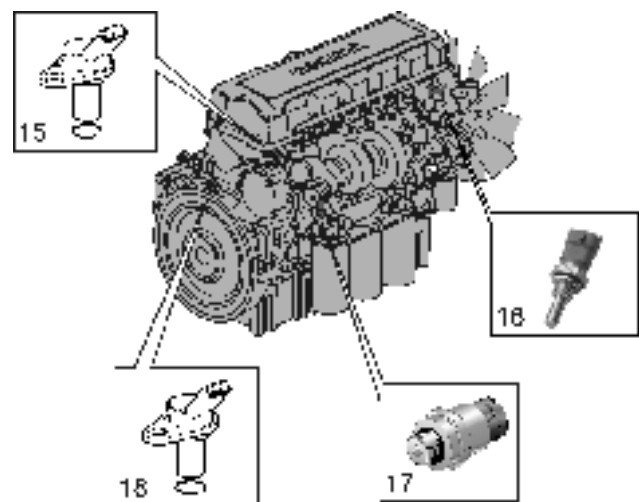
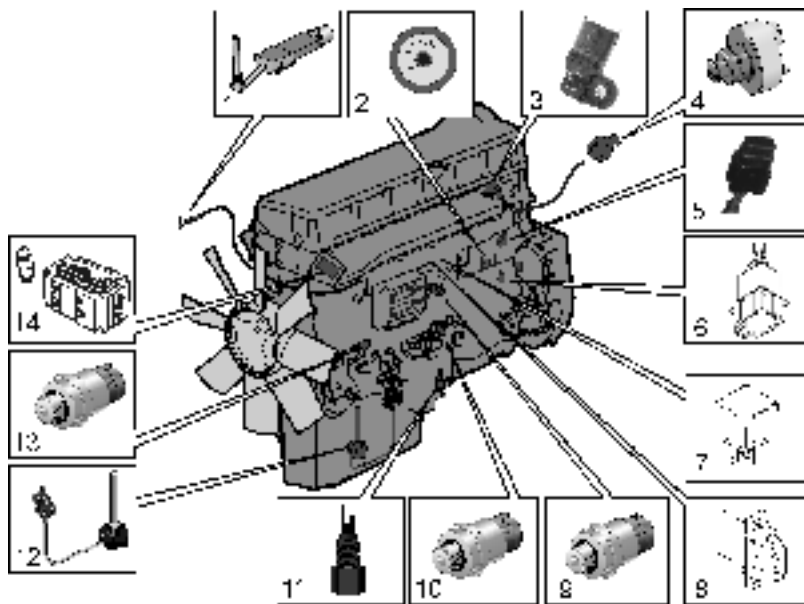

1. Coolant level sensor (in the expansion tank)
2. Extra stop
3. Charge pressure / charge temperature sensor
4. Air filter pressure sensor and air temperature sensor
5. Main circuit breaker 10 A
6. Connector block interface (8 pin contact)
7. Main relay
8. Diagnostic connector (2-pin connector)
9. Oil pressure sensor
10. Fuel pressure sensor
11. Sensor, water in fuel
12. Oil level and oil temperature sensor (installed inside the oil pan)
13. Crankcase pressure sensor
14. Air pre-heater with pre-heating relay
15. Camshaft position sensor
16. Coolant temperature sensor
17. Piston cooling pressure sensor
18. Flywheel position and speed sensor

Limit values

Limit values, control module (EMS 2) TAD1640–1642GE

Oil temperature

NOTE: The engine protection can be turned off.

| Preset alarm limit | Adjustable between | Alarm lamp is lit | Engine cut off |
|--------------------|--------------------------------|-------------------|----------------|
| 125 °C (257 °F) | 120 - 130 °C (248 - 266 °F) | at alarm limit | +5 °C (+41 °F) |

Oil pressure

NOTE: The engine protection can be turned off.

| Preset alarm limit | Adjustable between | Alarm lamp is lit | Engine cut off |
|----------------------------------|--------------------|-------------------|---------------------|
| idle: 160 kPa (23,21 Psi) | not adjustable | at alarm limit | 130 kPa (18,85 Psi) |
| 1500 rpm: 250 kPa (36,26 Psi) | not adjustable | at alarm limit | 220 kPa (31,91 Psi) |
| 1800 rpm: 300 kPa (43,51 Psi) | not adjustable | at alarm limit | 270 kPa (39,16 Psi) |

Oil level

| Preset alarm limit | Adjustable between | Alarm lamp is lit | Engine cut off |
|--------------------|--------------------|-------------------|----------------|
| low oil level | not adjustable | low oil level | no |

Coolant temperature

NOTE: The engine protection can be turned off.

| Preset alarm limit | Adjustable between | Alarm lamp is lit | Engine cut off |
|--------------------|--------------------------------|-------------------|----------------|
| 98 °C (208 °F) | 95 -103 °C (203 - 217,4 °F) | at alarm limit | +5 °C (+41 °F) |

Coolant level

NOTE: The engine protection can be turned off.

| Preset alarm limit | Adjustable between | Alarm lamp is lit | Engine cut off |
|--------------------|--------------------|-------------------|-------------------|
| low coolant level | not adjustable | low coolant level | low coolant level |

Fuel pressure

| Preset alarm limit | Adjustable between | Alarm lamp is lit | Engine cut off |
|----------------------------------|--------------------|-------------------|----------------|
| See diagram, fuel pressure below | not adjustable | at alarm limit | no |

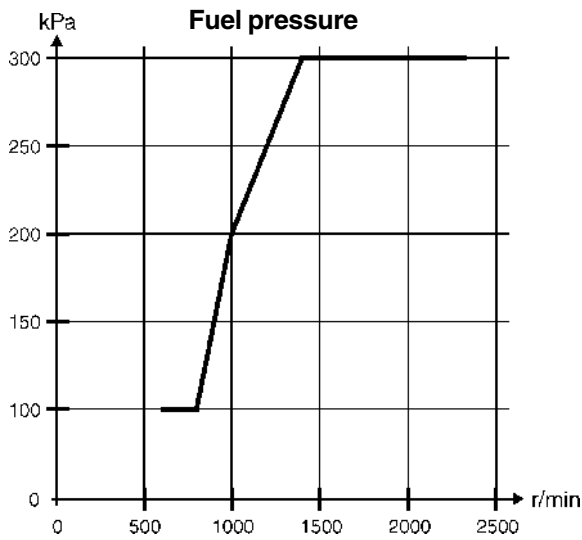

Water in fuel

| Preset alarm limit | Adjustable between | Alarm lamp is lit | Engine cut off |
|--------------------|--------------------|-------------------|----------------|
| water in fuel | not adjustable | water in fuel | no |

Crankcase pressure

NOTE: The engine protection can be turned off.

| Preset alarm limit | Adjustable between | Alarm lamp is lit | Engine cut off |
|---------------------|--------------------|---------------------|---------------------|
| increasing pressure | not adjustable | increasing pressure | increasing pressure |

Boost air temperature

NOTE: The engine protection can be turned off.

| Preset alarm limit | Adjustable between | Alarm lamp is lit | Engine cut off |
|--------------------|--------------------|-------------------|----------------|
| 80 °C (176 °F) | not adjustable | at alarm limit | +5 °C (+41 °F) |

Boost air pressure

NOTE: The engine protection can be turned off.

| Preset alarm limit | Adjustable between | Alarm lamp is lit | Engine cut off |
|---------------------|--------------------|-------------------|----------------------|
| 390 kPa (56,56 Psi) | not adjustable | at alarm limit | +10 kPa (+ 1,45 Psi) |

RPM

NOTE: Engine safety device may be put on.

| Preset alarm limit | Adjustable between | Alarm lamp is lit | Engine cut off |
|-----------------------|--------------------|-------------------|----------------|
| 20 % above normal rpm | 0 - 20 % | at alarm limit | no |

Limit values, control module (EMS 2) TAD1641–1642VE

Oil temperature

NOTE: The engine protection can be turned off.

| Preset alarm limit | Adjustable between | Alarm lamp is lit | Torque limitation | Engine cut off |
|--------------------|--------------------------------|-------------------|-------------------|----------------|
| 125 °C (257 °F) | 120 - 130 °C (248 - 266 °F) | at alarm limit | no | +5 °C (+41 °F) |

Oil pressure

NOTE: The engine protection can be turned off.

| Preset alarm limit | Adjustable between | Alarm lamp is lit | Torque limitation | Engine cut off |
|---------------------------------|--------------------|-------------------|---|---------------------|
| See diagram oil pressure below. | not adjustable | at alarm limit | max 900 Nm (664 lbf-ft) at alarm limit | -30 kPa (-4,35 Psi) |

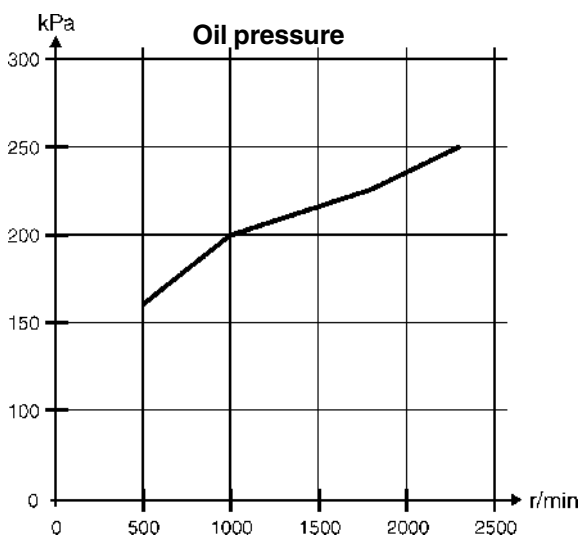

Oil level

| Preset alarm limit | Adjustable between | Alarm lamp is lit | Torque limitation | Engine cut off |
|--------------------|--------------------|-------------------|-------------------|----------------|
| low oil level | not adjustable | low oil level | no | no |

Coolant temperature

NOTE: The engine protection can be turned off.

| Preset alarm limit | Adjustable between | Alarm lamp is lit | Torque limitation | Engine cut off |
|--------------------|---------------------------------|-------------------|-------------------|----------------|
| 98 °C (208 °F) | 95 - 103 °C (203 - 217,4 °F) | at alarm limit | no | +5 °C (+41 °F) |

Coolant level

NOTE: The engine protection can be turned off.

| Preset alarm limit | Adjustable between | Alarm lamp is lit | Torque limitation | Engine cut off |
|--------------------|--------------------|-------------------|-------------------|----------------|
| low coolant level | not adjustable | low coolant level | no | no |

Fuel pressure

| Preset alarm limit | Adjustable between | Alarm lamp is lit | Torque limitation | Engine cut off |
|-----------------------------------|--------------------|-------------------|-------------------|----------------|
| See diagram, fuel pressure below. | not adjustable | at alarm limit | no | no |

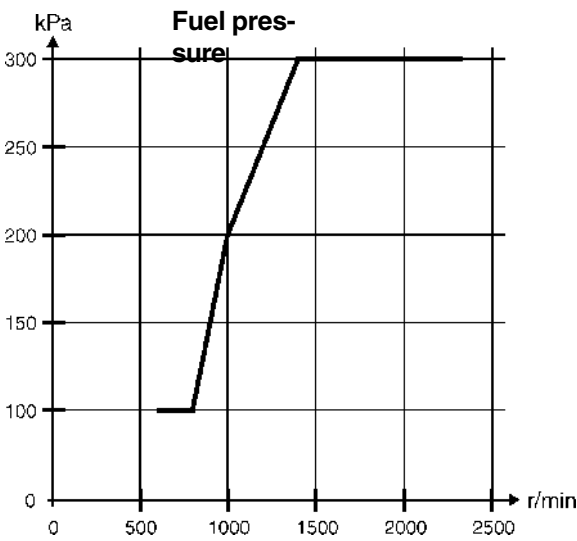

Water in fuel

| Preset alarm limit | Adjustable between | Alarm lamp is lit | Torque limitation | Engine cut off |
|--------------------|--------------------|-------------------|-------------------|----------------|
| water in fuel | not adjustable | water in fuel | no | no |

Crankcase pressure

NOTE: The engine protection can be turned off.

| Preset alarm limit | Adjustable between | Alarm lamp is lit | Torque limitation | Engine cut off |
|---------------------|--------------------|---------------------|-------------------|--------------------------|
| increasing pressure | not adjustable | increasing pressure | no | with increasing pressure |

Boost air temperature

NOTE: The engine protection can be turned off.

| Preset alarm limit | Adjustable between | Alarm lamp is lit | Torque limitation | Engine cut off |
|---------------------------|---------------------------|--------------------------|--------------------------|-----------------------|
| 80 °C (176 °F) | not adjustable | at alarm limit | no | +5 °C (+41 °F) |

Boost air pressure

NOTE: The engine protection can be turned off.

| Preset alarm limit | Adjustable between | Alarm lamp is lit | Torque limitation | Engine cut off |
|---------------------------|---------------------------|--------------------------|--------------------------|-----------------------|
| 390 kPa (56,56 Psi) | not adjustable | at alarm limit | no | +10 kPa (+ 1,45 Psi) |

RPM

NOTE: Engine safety device may be put on.

| Preset alarm limit | Adjustable between | Alarm lamp is lit | Torque limitation | Engine cut off |
|---------------------------|---------------------------|--------------------------|--------------------------|-----------------------|
| 20 % above normal rpm | 0 - 20 % | at alarm limit | no | no |

**Limp-home value
(emergency regulation value)**

The basic value is used by the control unit in order to continue running the engine when a technical fault occurs in the system or it's peripherals, sensors etc.

The following value (Limp home-value) is stored in the control unit:

| | |
|-----------------------|-------------------|
| Boost air temperature | +40 °C (+104 °F) |
| Coolant temperature | -15 °C (+5 °F) |
| Boost air pressure | See diagram below |
| Engine speed | rpm is frozen |

Charge air pressure GE

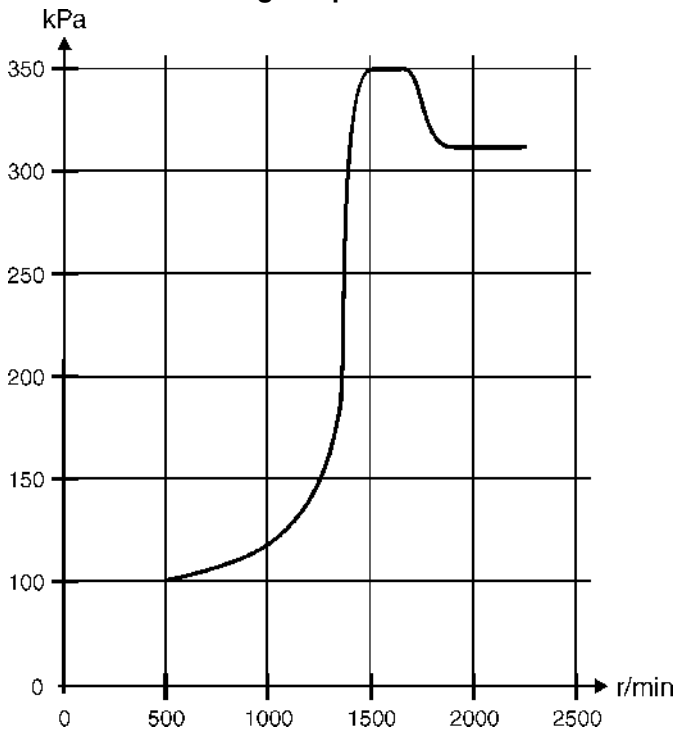

Charge air pressure VE

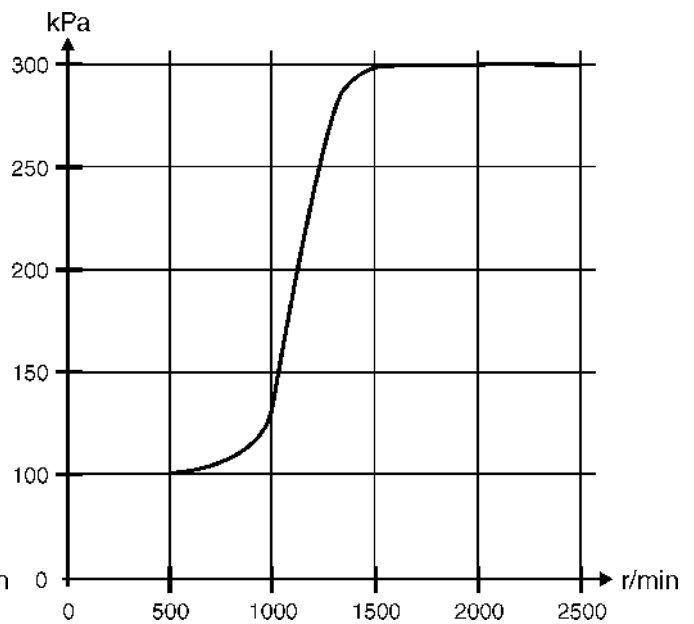

Repair instructions

When working with EMS 2 system

Follow the instructions below so as not to damage the EMS 2-system control unit:

- Never switch off main power while the engine is running.
 - Never disconnect a battery cable while the engine is running.
 - When fast charging the batteries, turn off the main switch or disconnect one of the battery cables. The main switch does not need to be turned off during normal charging.
 - Only batteries may be used for starting assistance. Starting boosters can generate excessive voltages and damage the control units.
 - Disconnect power to the EMS 2-system before removing the two 62-pin connectors from the control unit.
 - If damage to the cable harness is detected, the 62-pin connectors on the control unit must be removed.
-  **IMPORTANT!** Disconnect the 62-pin connectors from the control unit if you are about to perform welding.
- Make sure that the connector pins are not contaminated with oil or other liquids while disconnected. Otherwise a contact problem may arise or the oil may run down inside to the pressure sensitive membrane and cause a misreading.

Control module (EMS 2), replace

⚠ WARNING! Exchange of control units between engines, during fault tracing or repair, must never be performed under any circumstances..

1. Clean thoroughly around the control module fuel connections.
2. Remove electricity from the engine by disconnecting the negative battery terminal.
3. Remove the lower part of the crankcase ventilation pipe.
4. Remove upper and lower cable harnesses clamps.
5. Remove the control module's cable harness by moving the connector block's retaining clips outwards.
6. Remove upper and lower fuel connections with the cooling element, plug the fuel lines.
7. Remove the screws that hold the control module and remove the control module.
8. Transfer the cooling element to the new control module. Make sure that the surface between the cooling element and the control module is clean.
9. Install the new control module. Torque as specified in Technical data.
10. Install upper and lower fuel connections to the cooling element with new sealing washers.
11. Install the cable harness and clamps.
12. Install the lower crankcase ventilation pipe.
13. Vent the fuel system, see Fuel System, bleeding. Start the engine and check for error codes.

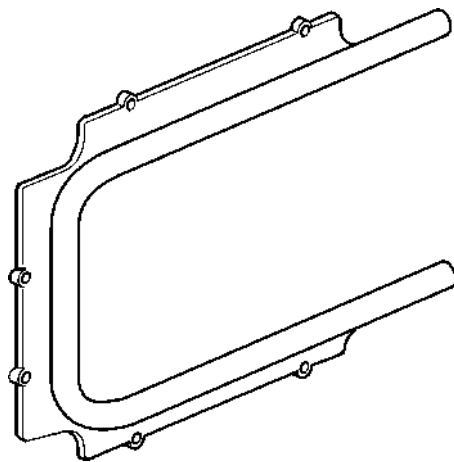
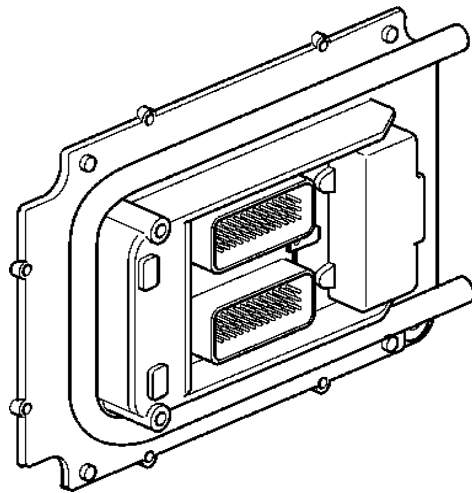

Unit injector, replacing

For replacement of unit injectors see:

”Workshop Manual Group 21-26 Industrial engine
TAD1640GE, TAD1641GE, TAD1642GE,
TAD1641VE, TAD1642VE”

When a unit injector has been replaced, a new injector code must be programmed into the EMS 2-control unit. This is done with the VODIA tool.

Each unit injector has a unique code. The injector code, which comprises six characters, is stamped on the unit injector as a hexadecimal code.

In the illustration to the right, the injector code is 5D008A.

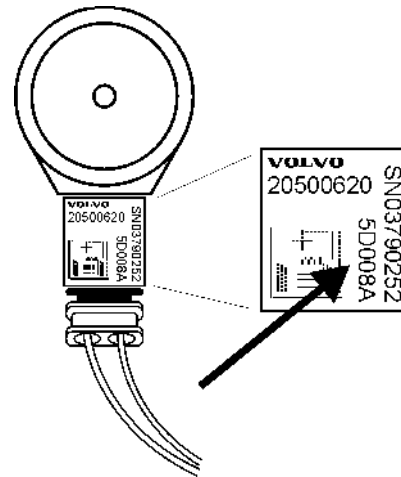

Starting with auxiliary batteries

⚠ WARNING! Ventilate well. Batteries can generate oxy-hydrogen, which is very flammable and highly explosive. A short circuit, open flame or spark could cause a violent explosion.

⚠ WARNING! Never mix up the battery cables positions on the battery. Mixing up the battery terminals when applying starting assistance can cause a short circuit and sparks, which could cause an explosion and also damage the engine's electrical components.

1. Check that the auxiliary battery's voltage is the same as the engine's system voltage.
2. First connect the red (+) jump lead to the discharged battery's **positive terminal (+)** and then to the auxiliary battery's **positive terminal (+)**.
3. Then connect the black (-) jump lead to the auxiliary battery's **negative terminal (-)** and to a suitable ground **somewhere away from the discharged battery's negative terminal (-)** e.g. to the negative cable on the starter motor.

⚠ WARNING! The black (-) jump lead must **under no circumstances** come in contact with the positive cable connection on the starter motor.

4. Start the engine and run at high idle for about 10 minutes to charge the batteries.

⚠ WARNING! Working with, or going close to a running engine is a safety risk. Watch out for rotating components and hot surfaces. Do not touch the connections during the starting attempt. Sparking hazard. Do not lean over any of the batteries.

5. Turn off engine. Remove the jump leads in **reverse order** to installation. **One lead at a time!**



Function check

Diagnostic function for VODIA

- The program can read off fault codes that are stored in the engine's control unit, check input/output signals and read off current values from the engine's sensors and then print out the test results.
- The program allows service and workshop personnel the rapidly detect and correct faults in the EMS 2-system.
- Connection to the engine's control unit is via the diagnostic outlet, see chapter "Electrical diagrams".
- User information is included with the program.
- To order the program, contact your Volvo Penta retailer.
- The task of the diagnostic function is to discover and locate any malfunctions in the EMS 2 system, to protect the engine and to ensure operation in the event of serious malfunction.
- If a malfunction is detected, this is indicated by the diagnostic lamp in the control panel blinking. By pressing the diagnostic switch, the operator will receive a fault code as a guide to any fault-tracing.

For more handling information, see "VODIA User's Guide".



Fault tracing

A number of symptoms and possible causes of engine malfunctions are described in the table below. Always contact your Volvo Penta dealer if any problems occur which you can not solve by yourself.

⚠ WARNING! Read the safety instructions for handling and service in the chapter "Safetyinformation" before starting work.

Symptoms and possible causes

| | |
|--|--|
| ✱ The diagnostic indicator is blinking | Please refer to the "Diagnostic information" chapter |
| Engine can not be stopped. | 2, 5 |
| Starter motor does not rotate | 1, 2, 3, 4, 5, 6, 7, 24 |
| Starter motor rotates slowly | 1, 2 |
| Starter motor rotates normally but engine does not start | 8, 9, 10, 11, |
| Engine starts but stops again | 8, 9, 10, 11, 13 |
| Engine does not reach correct operating speed at full throttle | 9, 10, 11, 12, 13, 21, 25, 26 |
| Engine runs roughly | 10, 11 |
| High fuel consumption | 12, 13, 15, 25 |
| Black exhaust smoke | 12, 13 |
| Blue or white exhaust smoke | 14, 15, 22 |
| Too low lubrication oil pressure | 16 |
| Excessive coolant temperature | 17, 18, 19, 20 |
| Too low coolant temperature | 20 |
| No, or poor charge | 2, 23 |

- | | | |
|---|---|--|
| 1. Flat batteries | 11. Water/contamination in fuel | 20. Defective thermostat |
| 2. Poor contact/open circuit in electrical cable | 12. Faulty unit injector | 21. Blocked intercooler |
| 3. Main switch turned off | 13. Insufficient air supply to the engine: –clogged air filter | 22. Too high oil level |
| 4. Main circuit breaker faulty | –air leakage between the turbo and the engine's inlet pipe | 23. Alternator drive belt slips |
| 5. Faulty ignition lock | –dirty compressor part in the turbocharger | 24. Water entry into engine |
| 6. Faulty main relay | –faulty turbocharger | 25. High back pressure in the exhaust system |
| 7. Faulty starter motor/solenoid | –poor engine room ventilation | 26. Break in "Pot+" cable to pedal |
| 8. No fuel: – fuel cocks closed | 14. Excessive coolant temperature | |
| – fuel tank empty/wrong tank connected | 15. Too low coolant temperature | |
| 9. Blocked secondary fuel filter/-primary filter (because of contamination, or stratification of the fuel at low temperature) | 16. Too low oil level | |
| 10. Air in the fuel system | 17. Coolant level too low | |
| | 18. Air in the coolant system | |
| | 19. Faulty circulation pump | |

Diagnostic function

The diagnostic function monitors and checks that the EMS 2 system functions normally.

The diagnostic function has the following tasks:

- Detecting and locating disturbances
- Reporting detection of disturbances
- Providing guidance when troubleshooting

Message regarding disturbance

If the diagnosis function detect a disturbance in the EMS 2 system, this is reported using fault codes via the instruments. Depending on which equipment is used, this is reported in various ways (fault codes can also be read using VODIA):

For DCU - Display Control unit:

- the text "!! ENGINE WARNING !!" shows on the display. **NOTE:** you can select the language with which the DCU will present the information.

For CIU - Control Interface Unit:

- the diagnostic lamp starts to flash

Simultaneously, the fault will be stored in the control module memory. As soon as the fault has been attended to and the ignition is turned off and on, the fault code will no longer show as active.

- DCU - the fault code shows as passive
- CIU - the diagnosis lamp turns off

Both rectified (passive) and un-rectified (active) faults are stored in the control unit.

For reading fault codes, see chapter Operation on page 34.

All fault codes are found in the fault code list with information about cause, reaction and actions, see chapter on "Fault codes."

NOTE: The indicated flashing codes apply only if the Volvo Penta CIU is used.

Effect on the engine

The engine is affected in different ways, depending on the seriousness of the fault detected by the diagnostic function.

A fault message in the form of a fault code is always generated when the diagnostic function discovers a fault.

The engine is affected by different degrees (see below) depending on the seriousness of the fault:

- The engine is not affected.
- Engine goes to idle speed (VE engines).
- Engine torque is limited to different levels (VE engine)
- Engine is shut off.

Operation

When a disturbance has occurred and the diagnosis system has generated one or more fault codes, these can be read either via:

- Plain text on instrument panel (DCU - Display Control unit).
- Diagnosis lamp on instrument panel (CIU - Control Interface Unit).
- The VODIA-tool. For handling, see "VODIA User's Guide"

If the system indicates that a fault code has been set:

1. Reduce engine speed to idle/shut down the engine.
2. For DCU: read which fault code has been set via the instrument panel, See "Reading fault codes via Display Control unit (DCU)."

or

For CIU: press in the diagnosis button and read the fault code via codes flashed by the diagnosis lamp, see "Reading fault codes via diagnosis lamp on instrument panel (CIU)".

3. Look up the fault code in the fault code list and take the necessary measures.

Reading fault codes via Display Control unit (DCU)

When a fault code has been set, the text "!! ENGINE WARNING !!" is shown alternating with "Press SEL for information".

NOTE: you can select the language with which the DCU will present the information.

By pressing the button SEL, you move to the fault list. The fault list shows:

- Running hours
- Fault
- Reason for fault
- Active/inactive

Press ESC to exit the fault list.

To access the fault list when no fault code has been set, press the button SEL to select the menu option Diagnostics.

Erasing fault codes (DCU)

Fault codes cannot be erased using DCU, but must be erased using VODIA.

Reading fault codes via the diagnosis lamp on instrument panel (CIU)

If the diagnosis knob is depressed and then released, a fault code will flash.

The fault code consists of two groups of flashes, separated by a pause of two seconds. A fault code is obtained by counting the number of flashes in each group.

Example: ✱ ✱ pause ✱ ✱ ✱ ✱ = Fault code 2.4

The fault code is stored and can be read as long as the malfunction remains. You can find information about cause, reaction and actions in the fault code list.

Read as follows:

1. Press the diagnostic button.
2. Release the diagnostic button and make a note of the fault that is flashed out.
3. Repeat items 1-2. A new fault code is flashed out if more are stored. Repeat until the first fault code is repeated.

NOTE: When the first fault code returns, all fault codes have been read.

Erasing fault codes (CIU)

The diagnosis function fault code memory is set to zero when the voltage to the engine is disconnected.

NOTE: Voltage must be fully disconnected.

When voltage is turned on again, the diagnosis function will check if there are any disturbances in the EMS 2 system. If this is the case, new fault codes are set.

This means that:

1. Fault codes for malfunctions that have been rectified or disappeared are set as inactive (the inactive fault code can then be erased with the VODIA tool).
2. Fault codes for malfunctions which have not been attended to must be acknowledged every time the system voltage is switched on.

If the diagnosis knob is depressed after the faults have been corrected, and stored fault codes have been deleted, code 1.1 ("No fault") will flash, see chapter on "Fault codes".

Fault codes EMS 2

⚠ WARNING! Read the safety instructions for handling and service in chapter "Safety information" before starting work.

NOTE: Reading the fault codes below, such as **PID 97, Code 2.1** means that **PID 97** is read using the diagnostic tool VODIA. **2.1** is the flashing code that is displayed by the instrument box diagnosis lamp. See "Reading fault codes".

NOTE: When there is a reference to sockets in the cable harness gloves to the engine control module, see wiring diagram page 67.

Code 1.1 No faults

No active faults exist.

PID 97, Code 2.1 Water in fuel

Reason:

- Water in fuel.

Reaction:

- Warning indicator.

Remedy:

- Drain fuel pre-filter.

PID 111, Code 2.2 Coolant level

Reason:

- Low coolant level.

Reaction:

- Warning indicator.
- VE engines: The engine control module limits engine output (unless protection has been turned off with the diagnosis tool VODIA).

GE engines: The engine is shut down (unless protection has been turned off with the diagnosis tool VODIA).

Remedy:

- Check coolant level.
- Check the coolant temperature sensor function.

PID 111, Code 2.3 Coolant level sensor

Reason:

- Shorted to plus (+).
- Sensor faulty.

Reaction:

- None.

Remedy:

- Check that the cable harness to coolant level sensor has not been damaged.
- Check coolant level sensor function.
- Check contact pressure in socket 23 and 10 in the upper cable glove (A) to the engine control module.

SID21, Code 2.4 Speed sensor, flywheel

Reason:

- No signal.
- Abnormal frequency.
- "Intermittent" signal from the sensor.
- Sensor faulty.

Reaction:

- The engine is very hard to start and runs unevenly if it starts.

Remedy:

- Check that the sensor contact has been installed correctly.
- Check that the cable harness to the speed sensor has not been damaged.
- Check that the speed sensor was installed correctly in the flywheel casing.
- Check speed sensor function.
- Check contact pressure in socket 37 and 38 in the upper cable glove (A) to the engine control module.

SID22, Code 2.5 Speed sensor, camshaft wheel**Cause:**

- No signal.
- Abnormal frequency.
- Sensor faulty.

Reaction:

- The engine takes longer than normal to start. Engine runs normally when is running.

Remedy:

- Check that the speed sensor contact has been installed correctly.
- Check that the cable harness to the speed sensor has not been damaged.
- Check that the speed sensor was installed correctly in the upper timing gear cover.
- Check speed sensor function.
- Check contact pressure in socket 45 and 46 in the upper cable glove (A) to the engine control module.

PID 190, Code 2.6 Engine rpm**Reason:**

- Rpm too high.

Reaction:

- VE engines: None.
- GE engines: Engine is shut off (unless the protection has been shut off with the parameter setting tool).

Remedy:

- When the motor stops, look for the cause of high rpm.

PPID 132, Code 2.8 RPM-potentiometer connected to CIU**Reason:**

- Shorted to plus (+) or minus (-).
- Potentiometer faulty.

Reaction:

- VE engines: Engine goes to idle.

If you release the accelerator first, and the press it down again, the engine can be forced to run using the idle contact.

GE engines: Engine speed is maintained.

Remedy:

- Check that the potentiometer has been connected correctly.
- Check that the cable harness to the potentiometer has not been damaged.
- Check the potentiometer function.

PID 97, Code 2.9 Indicator for water in fuel**Reason:**

- Short.
- Break.
- Dial indicator faulty.

Reaction:

- None.

Remedy:

- Check the cable harness to dial indicator with regard to short and break.
- Check dial indicator function. Change indicator as necessary.

PID 100, Code 3.1 Oil pressure sensor**Reason:**

- Shorted to plus (+) or minus (-).
- Break.

Reaction:

- None.

Remedy:

- Check that the cable harness to the oil pressure sensor has not been damaged.
- Check that the oil pressure sensor has been connected correctly.
- Check contact pressure in socket 11 in the lower cable glove (B) to the engine control module.

PID 105, Code 3.2 Charge air temperature sensor**Reason:**

- Shorted to plus (+) or minus (-).
- Break.

Reaction:

- None.

Remedy:

- Check that the charge air temperature sensor contact has been installed correctly.
- Check that the cable harness to the charge air temperature sensor has not been damaged.
- Check that the charge air temperature sensor was installed correctly.
- Check the charge air temperature sensor function.
- Check contact pressure in socket 47 in the upper cable glove (A) to the engine control module.

PID 110, Code 3.3 Coolant temperature sensor**Reason:**

- Shorted to plus (+) or minus (-).
- Break.

Reaction:

- Pre-heating is also activated when the engine is hot.

Remedy:

- Check that the coolant temperature sensor contact has been installed correctly.
- Check that the cable harness to the coolant temperature sensor has not been damaged.
- Check that the coolant temperature sensor was installed correctly.
- Check the coolant temperature sensor function.

PID106/102, Code 3.4 Boost pressure sensor**Reason:**

- Shorted to plus (+) or minus (-).
- Break.

Reaction:

- The engine smokes more than normal when accelerating or being loaded.

Remedy:

- Check that the charge air pressure sensor contact has been installed correctly.
- Check that the cable harness to the charge air pressure sensor has not been damaged.
- Check that the charge air pressure sensor was installed correctly.
- Check the charge air pressure sensor function.
- Check contact pressure in socket 22 in the upper cable glove (A) to the engine control module.

PID106/102, Code 3.5 Boost pressure**Reason:**

- Boost pressure too high

Reaction:

- VE engines: The engine control module limits engine output (unless protection has been turned off with the diagnosis tool VODIA).

GE engines: The engine is shut down (unless protection has been turned off with the diagnosis tool VODIA).

Remedy:

- Check turbocharger function.
- Check the charge air pressure sensor function.
- Check amount of fuel/unit injector.

PID 94, Code 3.6 Fuel pressure sensor**Reason:**

- Shorted to plus (+) or minus (-).
- Break.

Reaction:

- None.

Remedy:

- Check that fuel pressure sensor contact has been installed correctly.
- Check that the wiring to the fuel pressure sensor has not been damaged.
- Check that fuel pressure sensor was installed correctly.
- Check fuel pressure sensor function.
- Check contact pressure in socket 16 in the lower cable glove (B) to the engine control module.

PID175, Code 3.7 Oil temperature sensor**Reason:**

- Shorted to plus (+) or minus (-).
- Break.

Reaction:

- None.

Remedy:

- Check that the cable harness to the oil temperature sensor has not been damaged.
- Check that the oil temperature sensor has been connected correctly.
- Check contact pressure in socket 31 in the upper cable glove (A) to the engine control module.

PID 94, Code 3.8 Fuel pressure**Reason:**

- Low feed pressure.

Reaction:

- Warning indicator.

Remedy:

- Check if it is possible to increase pressure using the hand pump.
- Check fuel filter.
- Check fuel pre-filter.

PID 158, Code 3.9 Battery voltage**Reason:**

- Alternator faulty.
- Battery, battery cables faulty.

Reaction:

- Warning indicator.

Remedy:

- Check feed voltage from the control module.

PPID 5, Code 5.1 Main relay**Reason:**

- Shorted to plus (+).

Reaction:

- The instrument panel is disconnected from power when the key is turned to start position. Engine can not be started.

Remedy:

- Check that the cable harness to the relay has not been damaged.
- Check relay function.

PPID 4, Code 5.2 Start input, CIU**Reason:**

- Shorted to minus (-).
- Activated for too long.

Reaction:

- The engine cannot be started.
- The engine starts immediately when ignition is turned on.

Remedy:

- Check that connections to the ignition key have not been damaged.
- Check that the cable harness to the ignition key has not been damaged.

PPID 6, Code 5.3 Stop input CIU**Reason:**

- Shorted to minus (-).
- Break.
- Activated for too long.

Reaction:

- The engine can only be stopped with the auxiliary stop (AUX STOP) on the engine.
- Engine stops. A fault code is displayed for 40 seconds and the engine can not be started during this time. When a fault code is active, the engine can be started but not stopped.

Remedy:

- Check that connections to the ignition key have not been damaged.
- Check that the cable harness to the ignition key has not been damaged.

PID 45, Code 5.4 Pre-heating relay**Reason:**

- Shorted to plus (+) or minus (-).
- Break.

Reaction:

- Pre-heating cannot be activated.
- Pre-heating is constantly connected.

Remedy:

- Check that the cable harness to the relay input has not been damaged.
- Check relay function.
- Check contact pressure in socket 25 in the lower cable glove (B) to the engine control module.

PID 107, Code 5.5 Pressure drop, air filter**Reason:**

- Blocked air filter.

Reaction:

- Warning indicator.

Remedy:

- Check the air filter.

PID 107, Code 5.6 Air filter sensor**Reason:**

- Shorted to plus (+) or minus (-).
- Break.

Reaction:

- None

Remedy:

- Check that the air filter sensor contact has been installed correctly.
- Check that the cable harness to air filter sensor has not been damaged.
- Check that the air filter sensor was installed correctly.
- Check the air filter sensor functionality.
- Check contact pressure in socket 31 in the lower cable glove (B) to the engine control module.

PID 98, Code 5.7 Oil level**Reason:**

- The oil level is too low.

Reaction:

- Warning indicator.

Remedy:

- Check the oil level.

PID 175, Code 5.8 Oil temperature**Reason:**

- The oil temperature is too high

Reaction:

- Warning indicator.
- VE engines: The engine control module limits engine output (unless protection has been turned off with the diagnosis tool VODIA).

GE engines: The engine is shut down (unless protection has been turned off with the diagnosis tool VODIA).

Remedy:

- Check the oil level.
- Check the oil temperature.
- Check the oil temperature sensor function.

PID 98, Code 5.9 Oil level sensor**Reason:**

- Shorted to plus (+) or minus (-).
- Break.

Reaction:

- None.

Remedy:

- Check that the cable harness to the oil level sensor has not been damaged.
- Check the oil level sensor function.
- Check contact pressure in socket 3 and 4 in the lower cable glove (B) to the engine control module.

PID 110, Code 6.1 Coolant temperature**Reason:**

- Coolant temperature too high.

Reaction:

- Warning indicator.
- VE engines: The engine control module limits engine output (unless protection has been turned off with the diagnosis tool VODIA).

GE engines: The engine is shut down (unless protection has been turned off with the diagnosis tool VODIA).

Remedy:

- Check coolant level.
- Check the charge air cooler (cleanliness).
- Check for air in the coolant system.
- Check the pressure cap on the expansion tank.
- Check the coolant temperature sensor function.
- Check the thermostat function. PID 98, Code 5.9 Oil level sensor

PID 105, Code 6.2 Charge air temperature**Reason:**

- Charge air temperature too high.

Reaction:

- VE engines: The engine control module limits engine output (unless protection has been turned off with the diagnosis tool VODIA).

GE engines: The engine is shut down (unless protection has been turned off with the diagnosis tool VODIA).

Remedy:

- Check the charge air cooler (cleanliness).
- Check the charge air temperature sensor function.

PPID 3, Code 6.3 Start output EMS 2**Reason:**

- Shorted to plus (+) or minus (-).
- Activated for too long.

Reaction:

- The engine cannot be started.
- The engine starts immediately when ignition is turned on.

Remedy:

- Check that connections to the ignition key have not been damaged.
- Check that the cable harness to the ignition key has not been damaged.

SID 231, Code 6.4 Data link (CAN), CIU**Reason:**

- Data link faulty (CAN), CIU.

Reaction:

- Instrument and warning lamps no longer work.

Remedy:

- Check that the 8-pin contact has not been damaged.
- Check that the cable harness between CIU and the engine control module has not been damaged.
- Check that socket 11 and 12 in contacts on CIU have not been damaged.
- Check contact pressure in socket 51 and 55 in the lower cable glove (B) to the engine control module.

SID 231, Code 6.5 Data link (CAN), EMS 2**Reason:**

- Internal fault in the control module.

Reaction:

- Engine not operating: engine can not be started. Engine running: engine idles and can only be stopped with the emergency stop.

Remedy:

- Check that the 8-pin contact has not been damaged.
- Check that the cable harness between CIU and the engine control module has not been damaged.
- Check that socket 11 and 12 in contacts on CIU have not been damaged.
- Check contact pressure in socket 51 and 55 in the lower cable glove (B) to the engine control module.

PID 100, Code 6.6 Oil pressure**Reason:**

- The oil pressure is too low.

Reaction:

- Warning indicator.
 - VE engines: The engine control module limits engine output (unless protection has been turned off with the diagnosis tool VODIA).
- GE engines: The engine is shut down (unless protection has been turned off with the diagnosis tool VODIA).

Remedy:

- Check the oil level.
- Check that oil filters are not blocked.
- Check system pressure valves and the safety valve in oil system.
- Check the oil pressure sensor function.
- Check contact pressure in socket 51 and 55 in the lower cable glove (B) to the engine control module.

PPID 8, Code 6.7 Piston cooling pressure**Reason:**

- Piston cooling pressure is too low.

Reaction:

- Engine stopped, applies to both GE and VE engines. The fault code is de-activated at engine speeds below 1000 rpm.

Remedy:

- Check that the oil pressure in the engine exceeds 175 kPa (25.4 psi).

PPID 8, Code 6.8 Piston cooling pressure sensor**Reason:**

- Shorted to plus (+) or minus (-).
- Break.

Reaction:

- None.

Remedy:

- Check that the piston cooling pressure sensor contact has been installed correctly.
- Check that the cable harness to the piston cooling pressure sensor has not been damaged.
- Check that the piston cooling pressure sensor was installed correctly.
- Check the piston cooling pressure sensor functionality.
- Check contact pressure in socket 10 and 14 in the lower cable glove (B) to the engine control module.

PID 158, Code 6.9 Battery voltage, CIU**Reason:**

- Shorted to minus (-).
- Faulty alternator
- Battery, battery cables faulty.

Reaction:

- Warning indicator.
- Problem when starting motor.

Remedy:

- Check feed voltage from the control module.
- Check the battery.
- Check alternator.

SID 1, Code 7.1 Unit injector cylinder #1**Reason:**

- Electric fault.
- Compression or unit injector faulty.

Reaction:

- The engine runs on 5 cylinders.
- Abnormal sound.
- Deteriorating performance.
- Cylinder balancing interrupted -> Uneven operation at low rpms and low load.

Remedy:

- Check contact pressure in socket 24 in the upper cable glove (A) to the engine control module.
- Check that the cable harness to the unit injectors has not been damaged.
- Check that connections to the unit injector have not been damaged.
- Check fuel feed pressure.
- Check the valve clearance.
- Run a compression test and check cylinder #1.
- Check contact pressure in socket 24 in the upper cable glove (A) to the engine control module.
- Check that the cable harness to the unit injectors has not been damaged.
- Check that connections to the unit injector have not been damaged.
- Check fuel feed pressure.
- Check the valve clearance.
- Run a compression test and check cylinder #1.

SID 2, Code 7.2 Unit injector cylinder 2#**Reason:**

- Electric fault.
- Compression or unit injector faulty.

Reaction:

- The engine runs on 5 cylinders.
- Abnormal sound.
- Deteriorating performance.
- Cylinder balancing interrupted -> Uneven operation at low rpms and low load.

Remedy:

- Check contact pressure in socket 16 in the upper cable glove (A) to the engine control module.
- Check that the cable harness to the unit injectors has not been damaged.
- Check that connections to the unit injector have not been damaged.
- Check fuel feed pressure.
- Check the valve clearance.
- Run a compression test and check cylinder #2.

SID 3, Code 7.3 Unit injector cylinder 3#**Reason:**

- Electric fault.
- Compression or unit injector faulty.

Reaction:

- The engine runs on 5 cylinders.
- Abnormal sound.
- Deteriorating performance.
- Cylinder balancing interrupted -> Uneven operation at low rpms and low load.

Remedy:

- Check contact pressure in socket 32 in the upper cable glove (A) to the engine control module.
- Check that the cable harness to the unit injectors has not been damaged.
- Check that connections to the unit injector have not been damaged.
- Check fuel feed pressure.
- Check the valve clearance.
- Run a compression test and check cylinder #3.

SID 4, Code 7.4 Unit injector cylinder 4#**Reason:**

- Electric fault.
- Compression or unit injector faulty.

Reaction:

- The engine runs on 5 cylinders.
- Abnormal sound.
- Deteriorating performance.
- Cylinder balancing interrupted -> Uneven operation at low rpms and low load.

Remedy:

- Check contact pressure in socket 56 in the upper cable glove (A) to the engine control module.
- Check that the cable harness to the unit injectors has not been damaged.
- Check that connections to the unit injector have not been damaged.
- Check fuel feed pressure.
- Check the valve clearance.
- Run a compression test and check cylinder #4.

SID 5, Code 7.5 Unit injector cylinder 5#**Reason:**

- Electric fault.
- Compression or unit injector faulty.

Reaction:

- The engine runs on 5 cylinders.
- Abnormal sound.
- Deteriorating performance.
- Cylinder balancing interrupted -> Uneven operation at low rpms and low load.

Remedy:

- Check contact pressure in socket 48 in the upper cable glove (A) to the engine control module.
- Check that the cable harness to the unit injectors has not been damaged.
- Check that connections to the unit injector have not been damaged.
- Check fuel feed pressure.
- Check the valve clearance.
- Run a compression test and check cylinder #5.

SID 6, Code 7.6 Unit injector cylinder 6#**Reason:**

- Electric fault.
- Compression or unit injector faulty.

Reaction:

- The engine runs on 5 cylinders.
- Abnormal sound.
- Deteriorating performance.
- Cylinder balancing interrupted -> Uneven operation at low rpms and low load.

Remedy:

- Check contact pressure in socket 40 in the upper cable glove (A) to the engine control module.
- Check that the cable harness to the unit injectors has not been damaged.
- Check that connections to the unit injector have not been damaged.
- Check fuel feed pressure.
- Check the valve clearance.
- Run a compression test and check cylinder #6.

PID 153, Code 7.7 Crankcase ventilation pressure**Reason:**

- Crankcase ventilation pressure too high.

Reaction:

- Warning indicator.
- The engine is shut down.

Remedy:

- Check whether the crankcase ventilation is clogged.
- Check whether cylinder liner, piston or piston rings are worn or damaged.

PID 153. Code 7.8 Crankcase ventilation pressure sensor**Reason:**

- Shorted to plus (+) or minus (-).
- Break.

Reaction:

- None.

Remedy:

- Check that the crankcase ventilation pressure sensor contact has been installed correctly.
- Check that the cable harness to the crankcase ventilation pressure sensor has not been damaged.
- Check that the crankcase ventilation pressure sensor was installed correctly.
- Check crankcase ventilation pressure sensor function.
- Check contact pressure in socket 28 in the lower cable glove (B) to the engine control module.

PID 172, Code 7.9 Air temperature sensor, inlet**Reason:**

- Shorted to plus (+) or minus (-).
- Break.

Reaction:

- None.

Remedy:

- Check that the air temperature sensor contact has been installed correctly.
- Check that the cable harness to the air temperature sensor has not been damaged.
- Check that the air temperature sensor was installed correctly.
- Check the air temperature sensor functionality.
- Check contact pressure in socket 29 in the upper cable glove (A) to the engine control module.

SID250, Code 9.2 Data link faulty (J1708/J1587)**Reason:**

- Data link faulty.

Reaction:

- Warning indicator.

Remedy:

- Check that the 8-pin contact has not been damaged.
- Check that the cable harness between CIU/DCU and the engine control module has not been damaged.
- Check that socket 22 and 37 in contacts on CIU have not been damaged.
- Check contact pressure in socket 33 and 34 in the upper cable glove (A) to the engine control module.

SID232, Code 9.3 Voltage feed to sensor**Reason:**

- Short.
- Fault in oil pressure and/or charge air pressure sensor.

Reaction:

- Incorrect values from oil pressure- and charge air pressure sensor.
- Fault code for oil pressure- and charge air pressure sensor.
- Low engine output.
- The instrument shows zero oil pressure and boost pressure.

Remedy:

- Check that the cable harness to oil pressure- and charge air pressure sensor has not been damaged.
- Check contact pressure in socket 7 in the upper cable glove (A) to the engine control module.
- Check oil pressure and charge air pressure sensors.

SID 254, Code 9.8 Control module fault, CIU**Reason:**

- EEPROM, CIU, faulty
- Flash memory, CIU faulty.
- Fault in control module, CIU

Reaction:

- CIU reverts to factory settings.
- The engine runs to idle.
- Engine cannot be started.

Remedy:

- Replace CIU-unit.

SID 240, Code 9.9 Memory fault in EMS**Reason:**

- Engine control module memory fault.

Reaction:

- Engine may not start.

Remedy:

- Replace the engine control module.

SID 253, Code 9.9 Data set memory EEPROM**Reason:**

- Internal fault in the control module
- Programming faulty.

Reaction:

- Engine does not start.

Remedy:

- Reprogram the control module. If the fault remains, change the control module.

SID 254, Code 9.9 Control module EMS**Reason:**

- Internal fault in the control module.

Reaction:

- Engine misfires.
- Engine does not start.

Remedy:

- Replace the engine control module.

Electrical fault tracing

General

Before performing electrical fault tracing, the following should be checked:

- Fault codes
- Fuel level and filter
- Air filter
- Battery
- Cable harness (visually)
- Main switch, fuses, connector block
- Connections to relay

Functional check of wiring and connector blocks

Connection problems

Loose connectors or occasionally recurring faults can be difficult to fault trace and often occur due to oxidation, vibration or poorly connected leads.

Wear can be another reason for faults. Therefore avoid disconnecting connector blocks if it is not necessary.

Other connector problems can arise due to pins, sockets and connector blocks being damaged.

Shake the lead and pull on the connector while measuring to help find damaged wiring.

The resistance in connectors, wiring and connections should be 0 Ohm.

A certain resistance is always present however, due to oxidation of connections.

If this resistance increases too much, it can lead to malfunctions. The size of the resistance before it starts causing malfunctions varies depending on how large a load the circuit is carrying.

Check the following:

- Look for oxidation that can worsen connector contact in the connections
- Check that the connector pins/sockets are undamaged, that they are properly inserted in the connector blocks and that the wires are properly connected to the pins.
- Test the connector blocks for good mechanical contact.
Use a loose pin for the test.

 **Important!** The control unit's (EMS 2) cable connector must only be checked with gauge 9998482.

- Push gauge 9998482 carefully into the connector sockets. Pull/push the gauge back and forth several times, check that the socket grips around the gauge. If the connector socket has insufficient gripping power, the socket must be replaced. See "Splicing cables for cable connectors".
- Fill connector sockets that have been checked with low temperature grease 1161417-9.

 **Important!** DIN connectors for the **pressure sensor** must not be filled with grease.

- Check that the wires are properly crimped. Avoid short crimps on wires to the connector pins/sockets.

Functional check of wiring and connector blocks

Check connections visually

Check the following:

- Look for oxidation that can worsen connector contact in the connections
- Check that the connector pins/sockets are undamaged, that they are properly inserted in the connector blocks and that the wires are properly connected to the pins.
- Test the connector blocks for good mechanical contact.
Use a loose pin for the test.
- Shake the lead and pull on the connector while measuring to help find damaged wiring.

Open circuit

Chafed or torn wiring as well as loose contacts can be possible fault causes.

Check, using the wiring diagram, which cable harness is used by the function. Start with the most likely cable harness in the circuit.

Check the following:

- Disconnect the connector blocks at both ends of the cable harness.
- Measure the resistance with multimeter 9510060 between the ends of the cable. Expected value ~ 0 Ω .
- Shake the lead and pull on the connector while measuring to help find damaged wiring.
- If the fault cannot be found, check the next cable harness according to the wiring diagram..

Connector resistance and oxidation.

The resistance in connectors, wiring and connections should be 0 Ω .

A certain resistance is always present however, due to oxidation of connections.

If this resistance increases too much, it can lead to malfunctions. The size of the resistance before it starts causing malfunctions varies depending on how large a load the circuit is carrying.

Check the following:

- Look for oxidation that can worsen connector contact in the connections
- Check that the connector pins/sockets are undamaged, that they are properly inserted in the connector blocks and that the wires are properly connected to the pins.
- Test the connector blocks for good mechanical contact.
Use a loose pin for the test.



Important! DIN connectors for the **pressure sensor** must not be filled with grease.

Splicing cables for cable connectors

Special tools: 951 2636, 9999324

Repair kit: 1078054

1. Disconnect the connector block from the control unit, see "Control unit, replace". Dismantle the connector block so that the pin/socket to be replaced is accessible.
2. Remove the pin/socket with tool 9512636 or with a very small jewelers screwdriver.

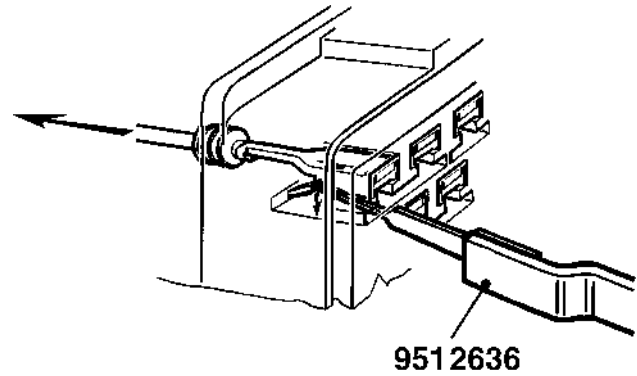

NOTE: Only remove one pin at a time.

3. Cut off the wire with the pin that is to be replaced. Splice in the new part from repair kit 1078054. Use crimping tool 9999324.
4. Carefully heat the splice with a hot air gun, so that the insulation shrinks around the wire.
5. Replace the pin in the correct position in the connector block before removing the next pin, if several pins are to be replaced. Check that the locking tab engages and locks the pin in the connector block.
6. Reassemble the wiring with insulation and cable ties in the connector block, in the reverse order to dismantling.
7. Reassemble the connector block in the reverse order to dismantling.
8. Ensure that the cable connector and connector on the control unit are clean and dry.
9. Fit the cable connector block onto the control unit, see "Control unit, replacement".
10. Start the engine and check for error codes.

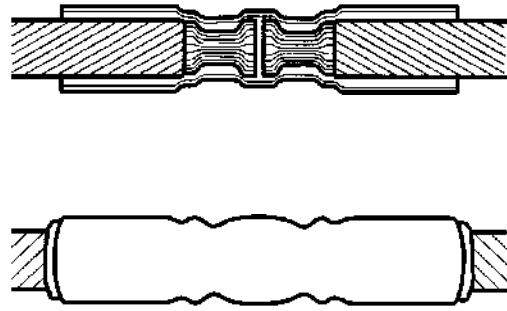
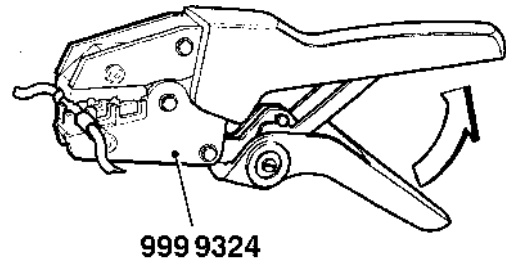

Check of combination sensor, charge air pressure/charge air temperature



Check of sensor, coolant temperature



Check, charge air pressure

1. Turn off engine
2. Disconnect connector A on the control unit and connect the 62-pin adapter 9998699 between the control unit and cable harness. Then connect multimeter 9510060 between measurement points 7–11.
3. Turn on the control voltage.
4. Measure with the multimeter set to voltage measurement. Check that the multimeter shows 5.0 volt.
5. Now connect the multimeter between measurement points 11–22. The voltage should be approx 1.2 V at normal atmospheric pressure.

1. Turn off engine
2. Remove the contact and remove the sensor from the engine.
3. Measure using multimeter 9510060-8 between the sensor's two contact pins. The multimeter should display a value as shown in the adjacent diagram and graphic.

NOTE: The sensor is very sensitive to temperature changes. When measuring in the lower temperature ranges 0-40°C (32-104°F), it is sufficient to hold the sensor in your hand for the resistance value to drop rapidly.

Check, charge air temperature

1. Detach the connector to the charge pressure sensor.
2. Disconnect connector A on the control unit and connect the 62-pin adapter 9998699 to the cable harness with the control unit disconnected .
3. Measure with multimeter 9510060 set to resistance measurement between the adapter's measurement points 11 –47.
The multimeter should show the following values:

| | |
|----------|----------------|
| ~15800 Ω | -20 °C (-4 °F) |
| ~2500 Ω | 20 °C (68 °F) |
| ~850 Ω | 50 °C (122 °F) |

NOTE: Even if the resistance values in the table above are met, this is no guarantee that the sensor is not faulty.

Check of sensor, water in fuel

| Temperature | Resistance |
|----------------|------------|
| -20 °C (-4 °F) | 15462 Ω |
| -10 °C (14 °F) | 9397 Ω |
| 0 °C (32 °F) | 5896 Ω |
| 10 °C (50 °F) | 3792 Ω |
| 20 °C (68 °F) | 2500 Ω |
| 23 °C (73 °F) | 2057 Ω |
| 30 °C (86 °F) | 1707 Ω |
| 40 °C (104 °F) | 1175 Ω |
| 50 °C (122 °F) | 834 Ω |
| 60 °C (140 °F) | 596 Ω |
| 70 °C (158 °F) | 435 Ω |
| 80 °C (176 °F) | 323 Ω |

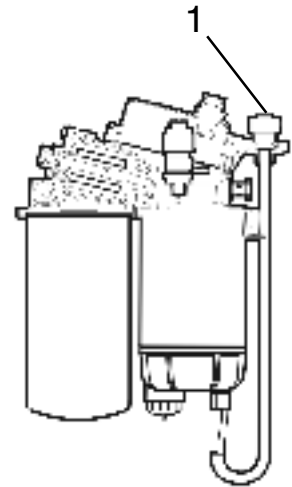

Coolant temperature

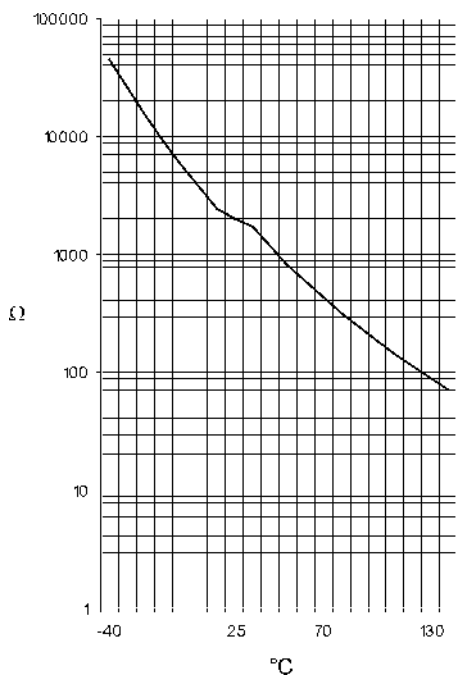

1. Disconnect the connector (1) to the water in fuel sensor.
2. Measure with multimeter 9510060 set to resistance, between the pins of the connector to the sensor.
3. The multimeter should show:
 - open circuit when the sensor is immersed in fuel
 - short circuit when the sensor is immersed in water.

Check of sensors, camshaft and flywheel



The speed sensors for the camshaft and flywheel are identical. For visual checking, first remove the sensor from the engine. Then remove the connection block and check that the sensor is not damaged and that no swarf/filings have stuck to the sensor.

The induction test is performed as follows:

1. Set multimeter 9510060 to resistance measurement. Measure with the multimeter on the connection pins. The resistance should be within 775–945 Ω .
2. Pass a metal object quickly and closely by the sensor. Check that the multimeter reacts. When replacing and installing sensor, make sure that any spacing shims are refitted.

Checking sensor, oil pressure

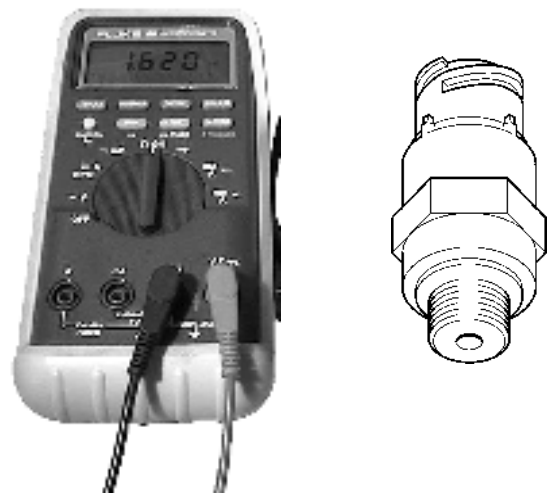

Check of oil pressure function

1. Turn off engine
2. Disconnect the oil pressure sensor connector block and connect the 4-pin adapter 9998534 between the oil pressure sensor's connector unit and the engine cable harness. Then connect the multimeter 9510060 between measurement points 1–4.
3. Turn on the control voltage.
4. Measure with the multimeter set to voltage measurement. Check that the multimeter shows 5.0 volt.
5. Now connect the multimeter between measurement points 2-4. Voltage should be about 0.5 V at normal atmospheric pressure.

Check of sensor, coolant level

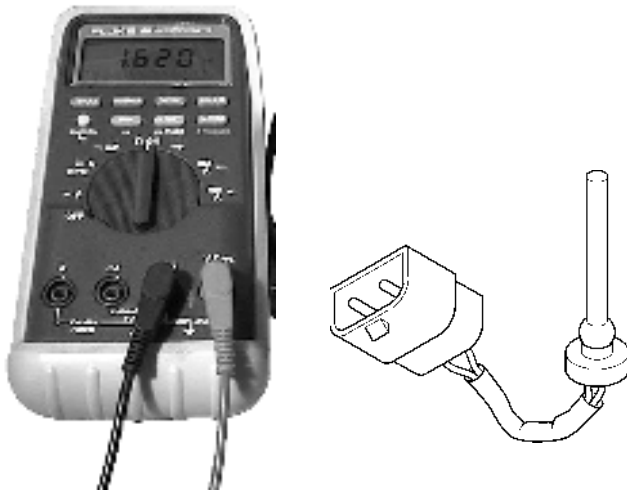

1. Empty the expansion tank from coolant.

⚠ WARNING! NEVER open the expansion tank pressure cap when the engine is hot, hot coolant can be sprayed out and cause severe burns.

2. Release the connector block from the coolant level sensor.
3. Check that the switch is activated and that it sends a signal when the expansion tank is empty.
4. Then fill the expansion tank with coolant and check that the resistance is infinite.

Checking combined sensor, oil level/oil temperature

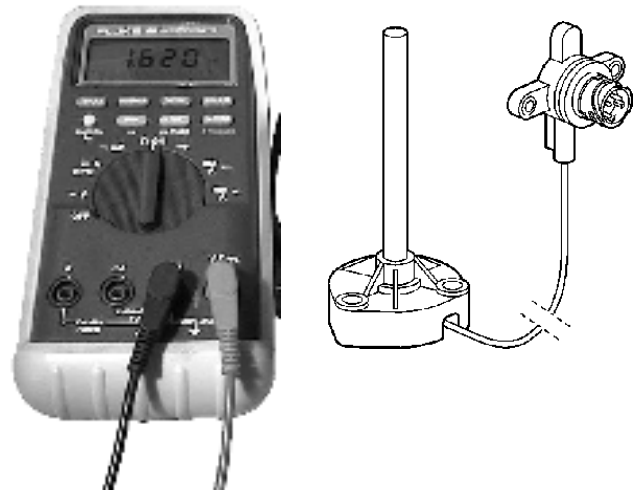

Check of oil level function

1. Remove connector block from the oil level sensor.
2. Measure using multimeter 9510060 between the sensor contact pins 1–2.
The multimeter should show 11.7 - 12.9 Ω at 22° C (72° F).

Check of oil temperature function

1. Remove the connector to the oil temperature sensor.
2. Connect the 4-pin adapter 9998534 between the oil pressure sensor connector and engine harness.
3. Measure with multimeter 9510060 adjusted to measure resistance between the adapter measurement points 3–4.
The multimeter should show the following values:

| | |
|----------------------------------|-----------------|
| 1520 Ω \pm 126 Ω | 25° C (77° F) |
| 378 Ω \pm 23 Ω | 60° C (140° F) |
| 104 Ω \pm 4 Ω | 100° C (212° F) |

NOTE: Even if the resistance values in the table above are met, this is no guarantee that the sensor is not faulty.

Check of sensor, fuel pressure



1. Turn off engine
2. Disconnect the oil pressure sensor connector block and connect the 7-pin adapter 9998567 between the oil pressure sensor's connector unit and the engine cable harness. Then connect the multimeter 9510060 between measurement points 1–4.
3. Turn on the control voltage.
4. Measure with the multimeter set to voltage measurement. Check that the multimeter shows 5.0 volt.
5. Now connect the multimeter between measurement points 2 – 4. Voltage should be about 0.5 V at normal atmospheric pressure.

Check of sensor, crankcase pressure

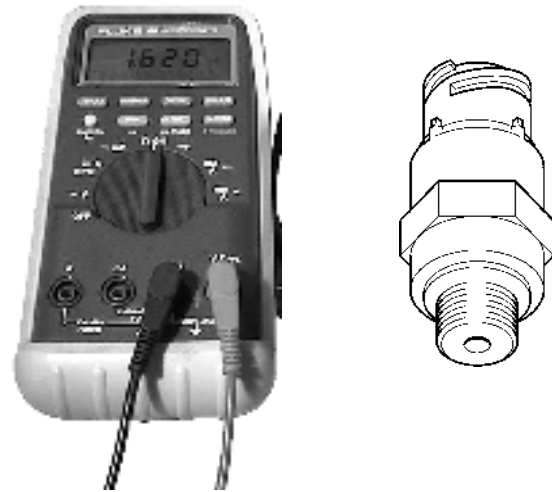

1. Turn off engine
2. Disconnect the charge air pressure sensor connector block and connect the 4-pin adapter 9998534 between the charge air pressure sensor's connector block and the engine cable harness. Then connect the multimeter 9510060 between measurement points 1–4.
3. Turn on the control voltage.
4. Measure with the multimeter set to voltage measurement. Check that the multimeter shows 5.0 volt.
5. Then connect the multimeter between measurement points 2 – 4. Voltage should be about 3 V at normal atmospheric pressure.

Checking combined sensor, air filter pressure/air



Checking air filter pressure function

1. Remove the connector from the sensor.
2. Connect the 4-pin adapter 9998534 between the oil pressure sensor connector and engine harness.
2. Measure with multimeter 9510060 adjusted to measure resistance between the adapter measurement points 1–2. The multimeter should show 330 Ω . If the measured value is 2.2 k Ω when the engine is shut-down, this means that the contact is stuck in active position.

Checking air temperature function

1. Detach the connector to the oil pressure sensor.
2. Connect the 4-pin adapter 9998534 between the oil pressure sensor connector and engine harness.
3. Measure with multimeter 9510060 adjusted to measure resistance between the adapter measurement points 3–4. The multimeter should show the following values:

| | |
|-----------------------------------|----------------|
| 16445 Ω \pm 822 Ω | 0 °C (32 °F) |
| 5000 Ω \pm 220 Ω | 25° C (77° F) |
| 4026 Ω \pm 160 Ω | 30° C (86° F) |
| 1246 Ω \pm 40 Ω | 60 °C (140 °F) |
| 463 Ω \pm 10 Ω | 90 °C (194 °F) |

NOTE: Even if the resistance values in the table above are met, this is no guarantee that the sensor is not faulty.

Fault tracing unit injectors

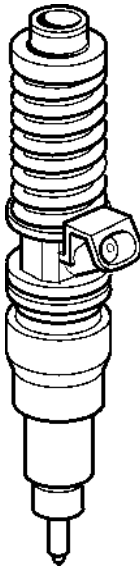

Fault symptom

Engine runs unevenly or has reduce performance.

Cause

The fault symptom above can have several causes:

- Faulty sensor signals
- Worn piston rings
- Blocked air filter
- Poor fuel
- Water in fuel
- Air in fuel
- Exhaust pressure too high
- Blocked fuel system
- Low fuel pressure
- Incorrect valve clearances
- Defective unit injector
- Start of piston seizure (engine failure)

Fault tracing starter motor and cabling

General

If the voltage level measured across the battery is less than 24.7V, the starter motor will not be able to crank the engine at normal speed.

Voltage measurement check

1. Check that the voltage across the battery is at least 24.7V unloaded, by measuring across the battery terminals with multimeter 9510060.
2. Turn on the main circuit breaker.
3. check that the voltage between terminals 30 and 31 on the starter motor is the same as the battery's.

Brushes

The specification for the starter motor brushes is given below.

Brush condition

New = 23 mm (0,91")

Replace at = 13 mm (0,51")

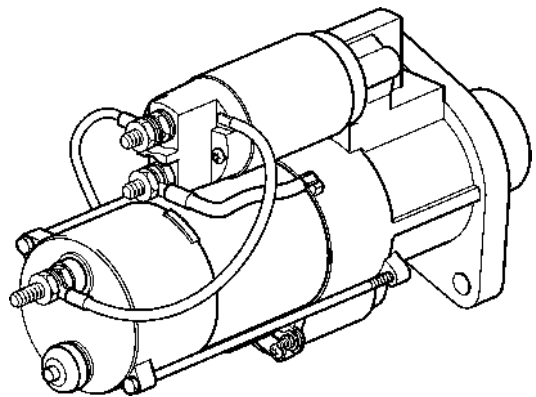

Functional check of relay

Multimeter 9510060 is used during the fault tracing procedure.

Two different symbols visualize conductor status. Symbol 1 indicates open circuit or very high resistance (~). The multimeter does not sound.

Symbol 2 indicates connection or very low resistance. The multimeter sounds.

Perform a functional check of the relay as follows:

NOTE: Remove the main relay from the engine before fault tracing.

1. Use the multimeter set to buzzer signal. Measure between relay pins 87a and 30. The multimeter should sound.
2. Use the multimeter set to buzzer signal. Measure between relay pins 87a and 30. The multimeter should sound.
3. Use the multimeter set to resistance measurement. Measure between relay pins 85 and 86. The multimeter should show 240–270 Ω.
4. Connect 24V between pins 85 and 86. Use the multimeter set to buzzer signal. Measure between relay pins 87 and 30. The multimeter should sound.
5. Connect 24V between pins 85 and 86. Use the multimeter set to buzzer signal. Measure between relay pins 87a and 30. The multimeter should not sound.
6. Replace the relay if the above test is not completed satisfactorily.

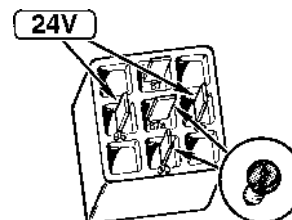
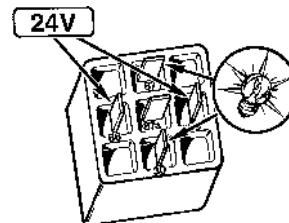
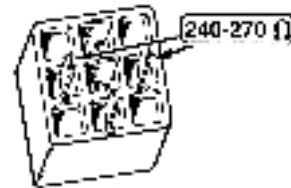
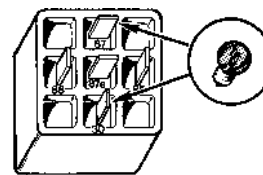
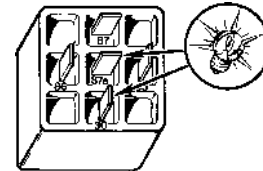
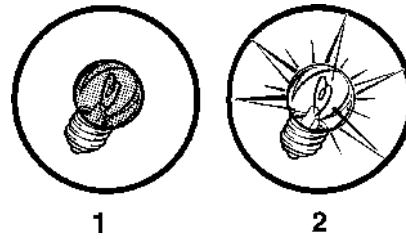

Electrical system

Important information - electrical system

 **Important!** Turn the engine off and turn off the power at the main switch(es) before carrying out work on the electrical system.

1. Battery main switch

Never break the circuit between the alternator and the battery while the engine is running.

The main switches must never be disconnected before the engine has been stopped.

If the circuit is broken while the engine is running, the voltage regulator can be destroyed and the alternator badly damaged.

Dis-/reconnection of the charging circuit should, for the same reason, never be performed while the engine is running. For simultaneous charging of two independent battery circuits, a Volvo Penta charging separator can be fitted to the standard alternator (accessory).

2. Batteries

Never mix up the battery's positive and negative terminals when fitting batteries.

Incorrect installation can result in serious damage to the electrical equipment.

Refer to the wiring diagram. The battery terminals should be well cleaned and the terminal clamps greased and properly tightened.

Fast charging of the batteries should be avoided. If fast charging must be performed, the ordinary battery cables must be removed first.

NOTE: Follow the appropriate safety regulations when charging batteries.

During charging, the cell covers should be loosened but not removed. Ventilate well, especially if the batteries are charged in an enclosed space.

Always discontinue the charging current **before** disconnecting the charging clips.

 **WARNING!** Never expose the battery area to naked flame or electrical sparks. Never smoke close to the batteries. The batteries generate oxy-hydrogen gas when charged, which forms an explosive gas when mixed with air. This gas is easily ignited and highly explosive.

Always use protective goggles when charging and handling the batteries.

Battery electrolyte contains sulfuric acid which is highly corrosive.

Should the battery electrolyte come into contact with unprotected skin wash off immediately using plenty of water. If battery acid comes in contact with the eyes, immediately flush with plenty of water and obtain medical assistance at once.

3. If starting with the help of auxiliary batteries, see "Starting with auxiliary batteries".

4. Connecting extra equipment

All extra equipment shall be connected to a separate connection box and correctly fused.

Extra power take-off directly from the instrument panel should be avoided. The permitted extra take off is however **totally max. 5A** (applies to all instrument panels together).

Electric welding

Remove the positive and negative cables from the batteries.

Then disconnect all cables connected to the alternator.

Then remove the cable connection from the control unit, see instructions in "Control unit (EMS 2), replace".

Always connect the welder ground clamp to the component to be welded, and as close as possible to the weld site. The clamp must never be connected to the engine or in such a way that current can pass through a bearing.

 **Important!** After welding is finished, the disconnected components such as cable connectors, alternator cables and battery cables must be refitted in the correct order.

Electrical system, overview

TAD1640-1642GE with CIU, CAN based SAE J1939

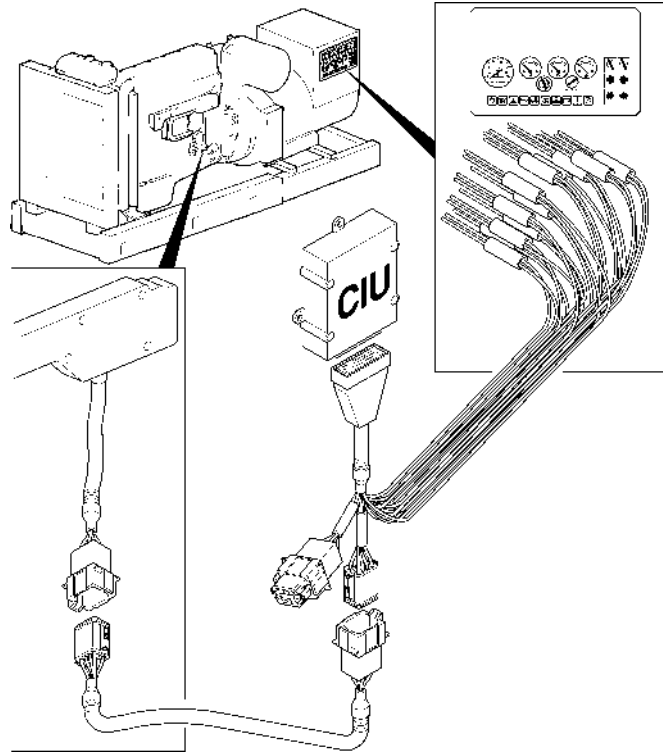

TAD1640-1642GE with DCU, CAN based SAE J1939

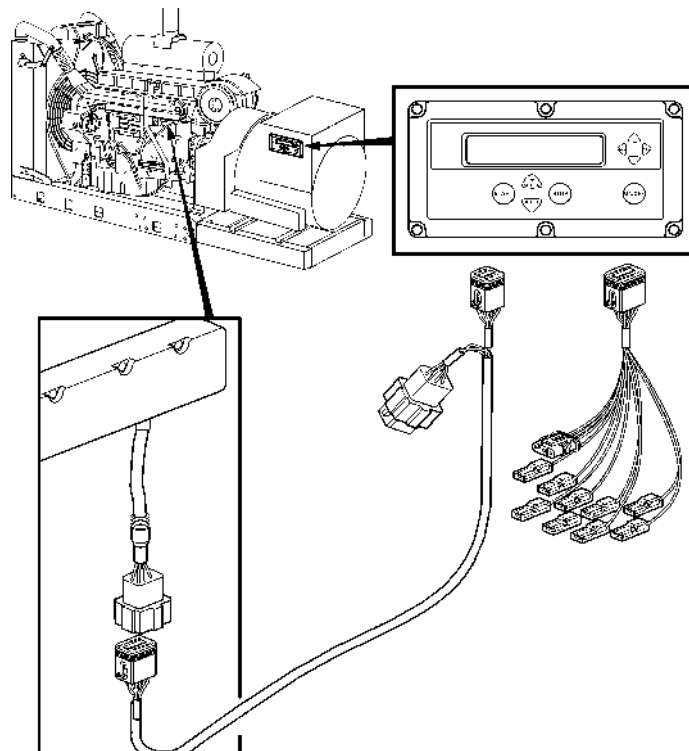

TAD1641-1642VE with CIU, CAN based SAE J1939

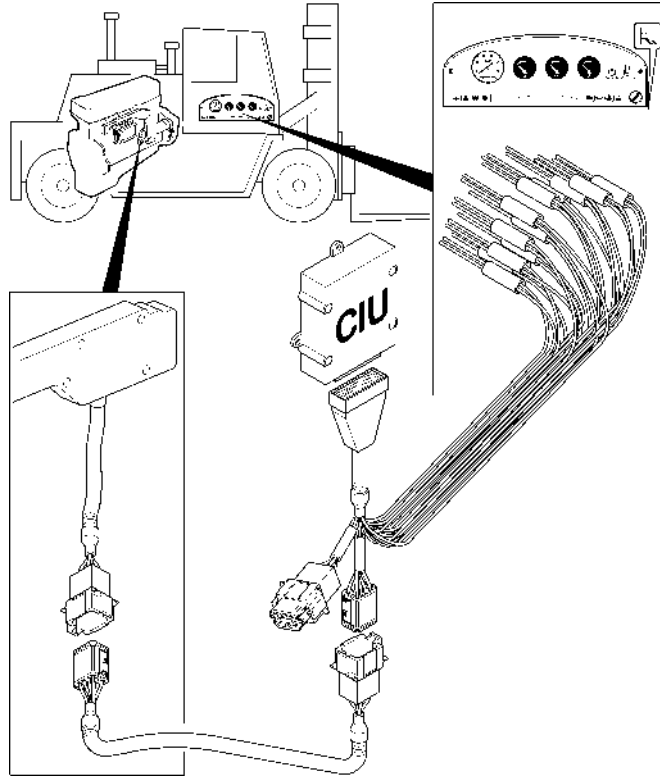

TAD1631641-1642VE with DCU, CAN based SAE J1939

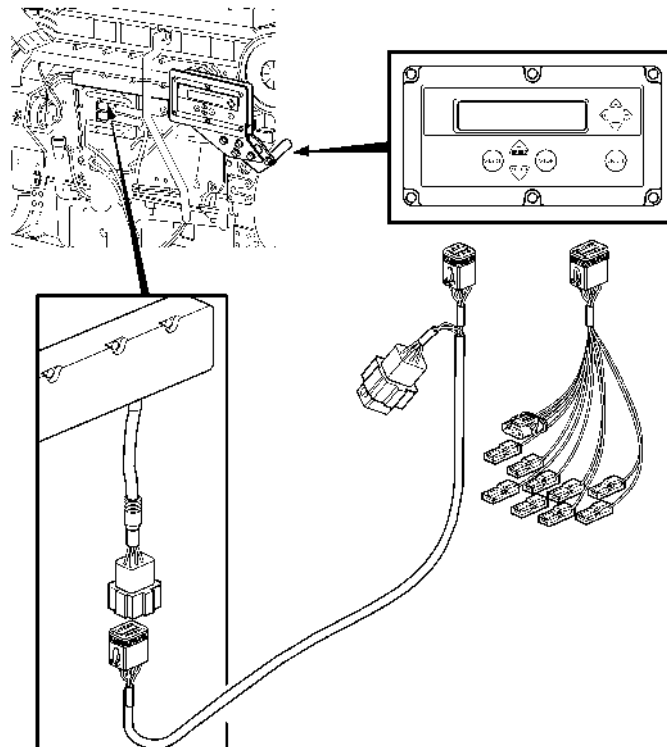

Electrical diagram EMS2

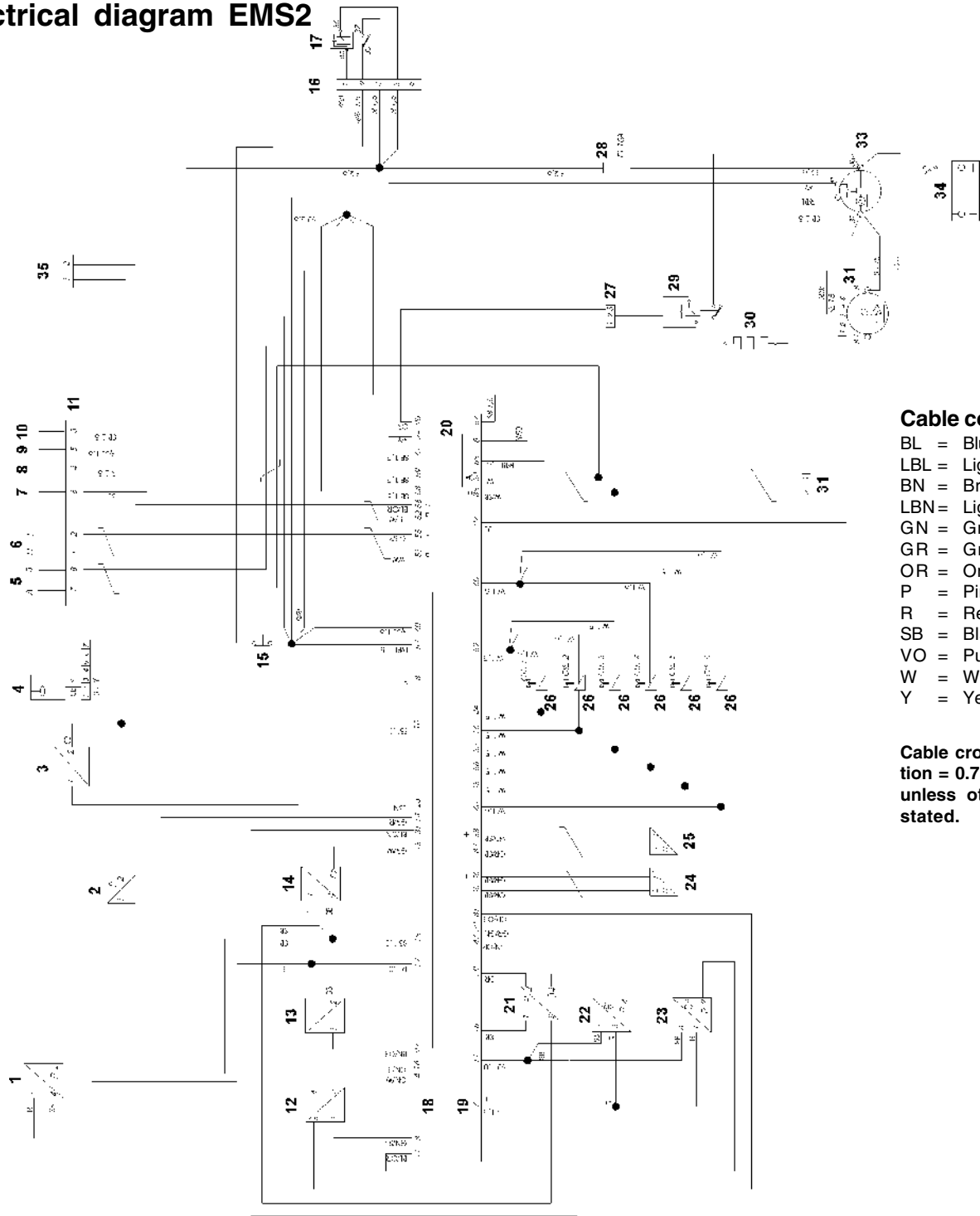

Cable colors

- BL = Blue
- LBL = Light blue
- BN = Brown
- LBN = Light brown
- GN = Green
- GR = Grey
- OR = Orange
- P = Pink
- R = Red
- SB = Black
- VO = Purple
- W = White
- Y = Yellow

Cable cross section = 0.75 mm² unless otherwise stated.

- | | |
|--|---|
| <ol style="list-style-type: none"> 1. Sensor, fuel pressure 2. Sensor, piston cooling pressure 3. Sensor, coolant level 4. Sensor, water in fuel 5. J1587 (bus) 6. J1939 CAN (bus) 7. Stop button 8. Battery plus 9. Voltage after key 10. Battery minus 11. Connector block data bus 12. Sensor, oil level / oil temperature 13. Sensor, coolant temperature 14. Sensor, crankcase pressure 15. Extra stop 16. Relay socket 17. Main relay | <ol style="list-style-type: none"> 18. Connector block B 19. Connector block A 20. Control module EMS 2 21. Sensor, air filter pressure and air temperature 22. Sensor, charge air pressure / charge air temperature 23. Sensor, oil pressure 24. Sensor, camshaft 25. Sensor, flywheel 26. Unit injector (Cyl. 1-6) 27. Connector block 28. Main circuit breaker 10 A 29. Relay pre-heating 30. Pre-heating 31. VODIA input 32. Alternator 33. Starter 34. Battery (24 V) 35. Connector block (not used) |
|--|---|

Wiring diagram CIU

Cable colors

| | |
|------------------|-------------|
| BL = Blue | P = Pink |
| LBL = Lightblue | R = Red |
| BN = Brown | SB = Black |
| LBN = Lightbrown | VO = Purple |
| GN = Green | W = White |
| GR = Grey | Y = Yellow |
| OR = Orange | |

1. Key switch running power (15+)
2. RPM-potentiometer
3. Tachometer (code 14)
4. Oil pressure, instrument
5. Oil temperature, instrument
6. Coolant temperature, instrument illumination
7. Instrument illumination
8. Idle switch, two-position
9. 1500/1800 switch, two-position
10. Start switch, spring return
11. Stop switch, spring return
12. Diagnosis contact, spring return
13. Alarm, low oil pressure
14. Alarm, high oil temperature
15. Alarm, high coolant temperature
16. Alarm, low coolant level
17. Fuel alarm
18. Diagnostic lamp
19. Engine overspeed indication (GE)
20. Operation indicator
21. Pre-heating indication
22. Pre-heating contact
23. 8-pin Deutsch connecting plug
24. Regulator contact
25. Battery voltage alarm
26. Termination resistance 120 Ohm
27. 8-pin Deutsch connecting socket
28. Contact, engine protector disconnect (not connected on GE-engines)
29. Easy Link connector block
30. Control Interface Unit (CIU)

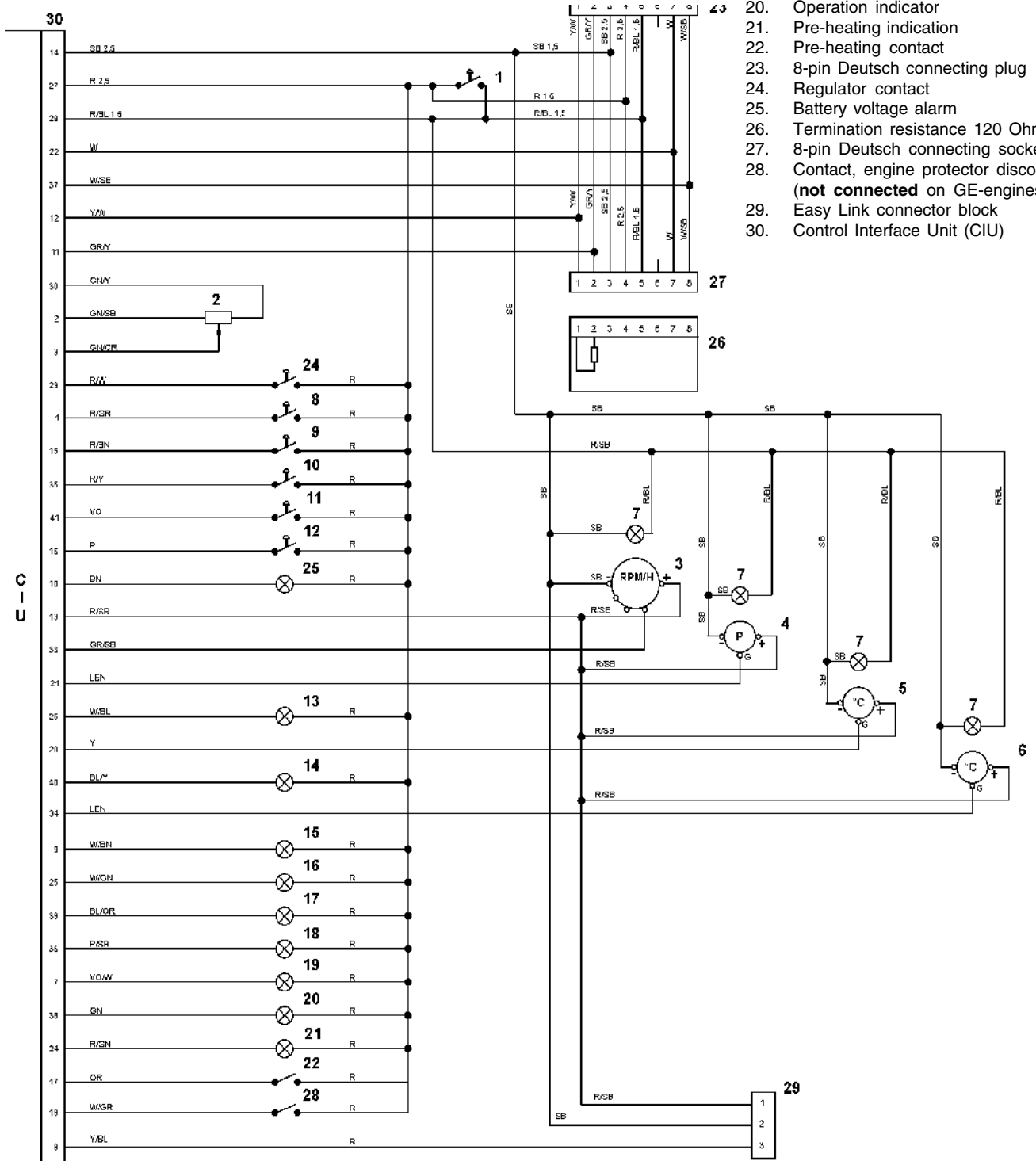

Wiring diagram DCU

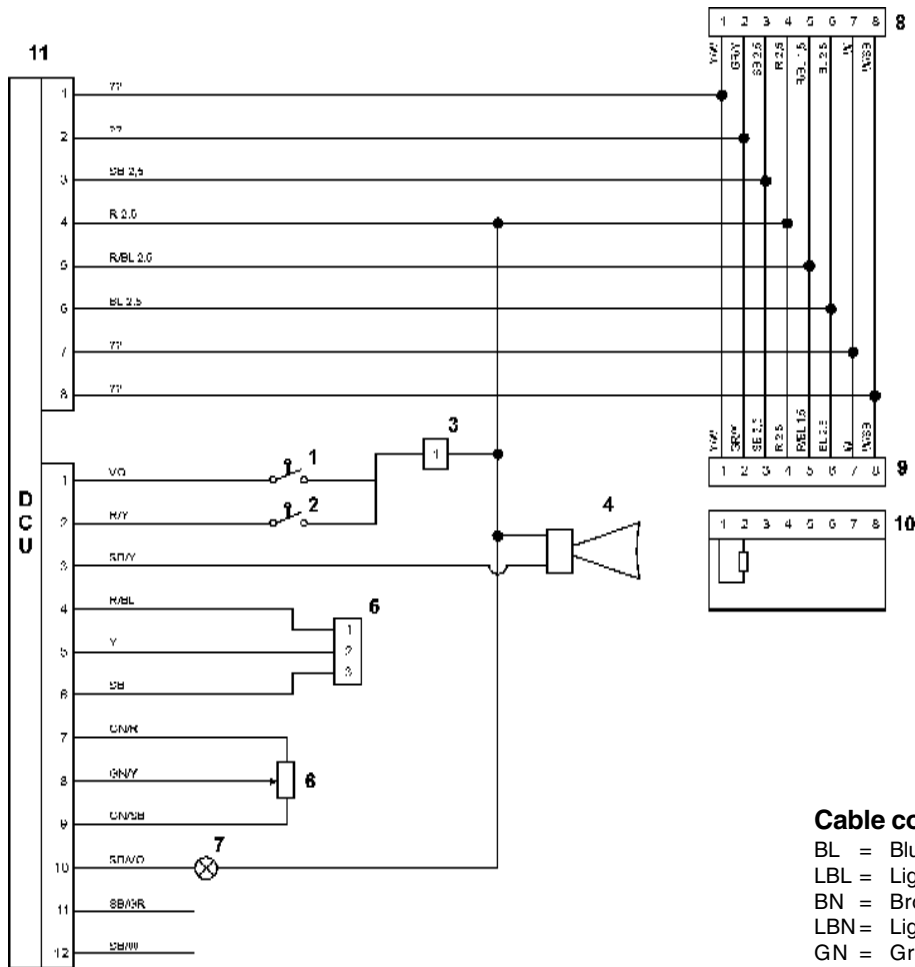

- 1. Start contact
- 2. Stop contact
- 3. 1-pin connector block
- 4. Horn, buzzer alarm
- 5. Easy Link connector block
- 6. RPM-potentiometer
- 7. Indicator engine operation
- 8. 8-pin Deutsch connecting plug
- 9. 8-pin Deutsch connecting socket
- 10. Termination resistance 120 Ohm
- 11. Display Control unit (DCU)

Cable colors

- BL = Blue
- LBL = Light blue
- BN = Brown
- LBN = Light brown
- GN = Green
- GR = Grey
- OR = Orange
- P = Pink
- R = Red
- SB = Black
- VO = Purple
- W = White
- Y = Yellow

**Cable cross section
= 0.75 mm² unless
otherwise noted.**

Notes

Notes

A series of horizontal dotted lines for writing notes.

Report form

Do you have any complaints or other comments about this manual. Please make a copy of this page, write your comments down and send them to us. The address is at the bottom. We would prefer you to write in English or Swedish.

From:

.....
.....
.....

Refers to publication:

Publication No.: Date of issue:

Proposal/motivation:

.....
.....
.....
.....
.....
.....
.....
.....
.....
.....

Date:

Signed:

AB Volvo Penta
Technical Information
Dept. 42200
SE-405 08 Göteborg
Sweden

