





CONTENTS

RATINGS GUIDE

4	Olympian™ Diesel Ratings – 50 Hz
7	Olympian Diesel Ratings – 60 Hz
9	Olympian Diesel Rental Ratings
9	Diesel Ratings Definitions
11	Olympian Gas Ratings
15	Gas Ratings Definitions
17	Conversions
28	Product Support – Extended Service Coverage (ESC)
29	Notes





**OLYMPIAN
GENERATOR SETS**
DIESEL

DIESEL

50 Hz – INTERNATIONAL

OLYMPIAN INTERNATIONAL 50 Hz DIESEL RATINGS: 5.5 kVA – 80 kVA

50 Hz – kVA (ekW)			
Standby	Prime	Generator Set Model	Configuration
Single Phase Output – 1500 rpm			
6 (6)	5.5 (5.5)	GEK6SP3	Low BSFC
7.5 (7.5)	6.5 (6.5)	GEK7.5SP1	Low BSFC
7.5 (7.5)	6.8 (6.8)	GEP7.5SP4	EU Stage IIIA
10 (10)	9 (9)	GEK10SP1	Low BSFC
11 (11)	10 (10)	GEP11SP6	EU Stage IIIA
14 (14)	13 (13)	GEP14SP6	EU Stage IIIA
16.5 (16.5)	15 (15)	GEP16SP6	EU Stage IIIA
26 (26)	24 (24)	GEP26SP3	Low BSFC
26 (26)	24 (24)	GEP26SP6	EU Stage IIIA
35 (35)	32 (32)	GEP35SP11*	Low BSFC
40 (40)	36 (36)	GEP40SP5	Low BSFC
40 (40)	36 (36)	GEP40SP2	EU Stage II
50 (50)	45 (45)	GEP50SP4	EU Stage II
50 (50)	45 (45)	GEP50SP11*	Low BSFC
50 (50)	45 (45)	GEP50SP6	EU Stage IIIA
80 (80)	72 (72)	GEP80SP4	EU Stage II
80 (80)	72 (72)	GEP80SP6	EU Stage IIIA

All ratings at 1.0 pf and 27° C (80.6° F)

*Brazil-sourced only

4 DIESEL

DIESEL

50 Hz – INTERNATIONAL

OLYMPIAN INTERNATIONAL 50 Hz DIESEL RATINGS: 6.5 kVA – 110 kVA

50 Hz – kVA (ekW)			
Standby	Prime	Generator Set Model	Configuration
Three Phase Output – 1500 rpm			
7.5 (6)	6.5 (5.2)	GEK7.5-1	Low BSFC
9.5 (7.6)	8.5 (6.8)	GEK9.5-1	Low BSFC
9.5 (7.6)	8.5 (6.8)	GEP9.5-4	EU Stage IIIA
12.5 (10)	11 (8.8)	GEK12.5-1	Low BSFC
13.5 (10.8)	12.5 (10)	GEP13.5-6	EU Stage IIIA
18 (14.4)	16.5 (13.2)	GEP18-6	EU Stage IIIA
22 (17.6)	20 (16)	GEP22-6	EU Stage IIIA
33 (26.4)	30 (24)	GEP33-3	Low BSFC
33 (26.4)	30 (24)	GEP33-6	EU Stage IIIA
44 (35.2)	40 (32)	GEP44-9*	Low BSFC
50 (40)	45 (36)	GEP50-7	Low BSFC
50 (40)	45 (36)	GEP50-2	EU Stage II
55 (44)	50 (40)	GEP55-1	Low BSFC
55 (44)	50 (40)	GEP55-4	EU Stage II
65 (52)	60 (48)	GEP65-4	EU Stage II
65 (52)	60 (48)	GEP65-9	Low BSFC
65 (52)	60 (48)	GEP65-11*	Low BSFC
65 (52)	60 (48)	GEP65-6	EU Stage IIIA
88 (70.4)	80 (64)	GEP88-3	Low BSFC
88 (70.4)	80 (64)	GEP88-6	EU Stage IIIA
110 (88)	100 (80)	GEP110-4	EU Stage II
110 (88)	100 (80)	GEP110-6	EU Stage IIIA

All ratings at 0.8 pf and 27° C (80.6° F)

*Brazil-sourced only

DIESEL

50 Hz – INTERNATIONAL

OLYMPIAN INTERNATIONAL

50 Hz DIESEL RATINGS: 135 kVA – 450 kVA

50 Hz – kVA (ekW)			
Standby	Prime	Generator Set Model	Configuration
Three Phase Output – 1500 rpm			
150 (120)	135 (108)	GEP150-1	Low BSFC
165 (132)	150 (120)	GEP165-1	Low BSFC
150 (120)	135 (108)	GEP150-4	EU Stage II
165 (132)	149.8 (119.8)	GEP165-4	EU Stage II
200 (160)	180 (144)	GEP200-1	Low BSFC
200 (160)	180 (144)	GEP200-4	EU Stage II
220 (176)	200 (160)	GEP220-1	Low BSFC
250 (200)	230 (184)	GEH250-4	EU Stage II
275 (220)	250 (200)	GEH275-4	EU Stage II
300 (240)	275 (220)	GEH300-1	Low BSFC
330 (264)	300 (240)	GEH330-1	Low BSFC
400 (320)	350 (280)	GEP400-4	EU Stage II
400 (320)	350 (280)	GEP400-3	Low BSFC
450 (360)	400 (320)	GEP450-4	EU Stage II
450 (360)	400 (320)	GEP450-3	Low BSFC

All ratings at 0.8 pf and 27° C (80.6° F)

6 DIESEL

DIESEL

60 Hz – INTERNATIONAL

OLYMPIAN INTERNATIONAL 60 Hz DIESEL RATINGS: 6 ekW – 90 ekW

60 Hz – ekW (kVA)			
Standby	Prime	Generator Set Model	Configuration
Single Phase Output – 1800 rpm			
7 (7)	6 (6)	GEK6SP3	Low BSFC
8.8 (8.8)	8 (8)	GEP7.5SP4	EU Stage IIIA
9 (9)	8 (8)	GEK7.5SP1	Low BSFC
12 (12)	10.9 (10.9)	GEK10SP1	Low BSFC
13 (13)	12 (12)	GEP11SP6	EU Stage IIIA
17 (17)	15.5 (15.5)	GEP14SP6	EU Stage IIIA
19.4 (19.4)	17.6 (17.6)	GEP16SP6	EU Stage IIIA
40 (40)	36 (36)	GEP35SP11*	Low BSFC
45 (45)	40 (40)	GEP40SP5	Low BSFC
55 (55)	50 (50)	GEP50SP9	Low BSFC
55 (55)	50 (50)	GEP50SP11*	Low BSFC
90 (90)	82 (82)	GEP80SP4	EU Stage II

All ratings at 1.0 pf and 27° C (80.6° F)

*Brazil-sourced only

OLYMPIAN INTERNATIONAL 60 Hz DIESEL RATINGS: 6.4 ekW – 45 ekW

60 Hz – ekW (kVA)			
Standby	Prime	Generator Set Model	Configuration
Three Phase Output – 1800 rpm			
7.2 (9)	6.4 (8)	GEK7.5-1	Low BSFC
8.8 (11)	8 (10)	GEK9.5-1	Low BSFC
8.8 (11)	8 (10)	GEP9.5-4	EU Stage IIIA
12 (15)	11 (13.8)	GEK12.5-1	Low BSFC
13.2 (16.5)	12 (15)	GEP13.5-6	EU Stage IIIA
17.6 (22)	16 (20)	GEP18-6	EU Stage IIIA
20 (25)	18 (22.5)	GEP22-6	EU Stage IIIA
30 (37.5)	27 (33.8)	GEP33-3	Low BSFC
40 (50)	36 (45)	GEP44-9*	Low BSFC
45 (56.3)	40 (50)	GEP50-7	Low BSFC

All ratings at 0.8 pf and 27° C (80.6° F)

*Brazil-sourced only

DIESEL

60 Hz – INTERNATIONAL

OLYMPIAN INTERNATIONAL 60 Hz DIESEL RATINGS: 45 ekW – 275 ekW

60 Hz – ekW (kVA)			
Standby	Prime	Generator Set Model	Configuration
Three Phase Output – 1800 rpm			
50 (62.5)	45 (56.3)	GEP55-1	Low BSFC
60 (75)	55 (68.8)	GEP65-9	Low BSFC
60 (75)	55 (68.8)	GEP65-11*	Low BSFC
80 (100)	72 (90)	GEP88-3	Low BSFC
100 (125)	90.4 (113)	GEP110-4	EU Stage II
132 (165)	120 (150)	GEP150-1	Low BSFC
174 (217.5)	157 (196.3)	GEP200-4	EU Stage II
200 (250)	180 (225)	GEH220-4	EU Stage II
212 (265)	192 (240)	GEH250-4	EU Stage II
275 (343.8)	250 (312.5)	GEH300-1	Low BSFC

All ratings at 0.8 pf and 27° C (80.6° F)

All models available with selected options to create rental configuration

*Brazil-sourced only

Standby

These ratings are for continuous operation (at variable load) and are based on performance is per generator set. These ratings are for continuous operation.

Prime

These ratings are for limited operation (at variable load) and are based on performance is per generator set. These ratings are for limited operation (10% of total capacity).

8 DIESEL

DIESEL

RENTAL AND RATINGS DEFINITIONS

OLYMPIAN RENTAL 50 Hz AND 60 Hz DIESEL RATINGS: 20 kVA – 250 kVA

50 Hz and 60 Hz – kVA (ekW)				
RPM	Prime	RPM	Prime	Generator Set Model
Three Phase Output				
1500	20	—	—	XQE20-4*
1500	30	1800	34	XQE30-2*
1500	30	1800	34	XQE30-4**
1500	60	1800	65	XQE60-2
1500	60	1800	65	XQE60-4**
1500	80	1800	83	XQE80-2*
1500	100	1800	106	XQE100-2*
1500	150	1800	163	XQE150-2*
1500	200	1800	225	XQE200-2*
1500	250	—	—	XQE250-2*

All ratings at 0.8 pf and 27° C (80.6° F)

*Subject to availability

**EU Stage IIIA

DIESEL RATINGS DEFINITIONS

Standby Rating

These ratings are applicable for supplying continuous electrical power (at variable load) in the event of a utility power failure. No overload is permitted on these ratings. The alternator on this model is peak continuous rated (as defined in ISO 8528-3).

Prime Rating

These ratings are applicable for supplying continuous electrical power (at variable load) in lieu of commercially purchased power. There is no limitation to the annual hours of operation and this model can supply 10% overload power for 1 hour in 12 hours.

OLYMPIAN GENERATOR SETS GAS



GAS

50 Hz – INTERNATIONAL

OLYMPIAN INTERNATIONAL 50 Hz GAS RATINGS: 20 kVA – 250 kVA

50 Hz					
RPM	Standby kVA (ekW)		Prime kVA (ekW)		Generator Set Model
	LP	NG	LP	NG	
Single Phase Output					
1500	20 (20)	20 (20)	—	—	**G25LTA2
1500	35 (35)	35 (35)	28 (28)	28 (28)	**G35LG1
1500	40 (40)	40 (40)	32 (32)	32 (32)	**G40LG1
1500	45 (45)	45 (45)	36 (36)	36 (36)	**G45LG1
1500	50 (50)	50 (50)	40 (40)	40 (40)	**G50LG1
1500	60 (60)	60 (60)	48 (48)	48 (48)	**G60LG1
1500	70 (70)	67 (67)	56 (56)	54 (54)	**G70LG1
1500	80 (80)	80 (80)	64 (64)	64 (64)	**G80LG1
1500	100 (100)	100 (100)	80 (80)	80 (80)	**G100LG1
1500	—	130 (130)	—	104 (104)	**G130LG1
1500	—	150 (150)	—	120 (120)	**G150LG1
1500	—	175 (175)	—	140 (140)	**G175LG1
Three Phase Output					
1500	25 (20)	25 (20)	—	—	*G25LTA2
1500	35 (28)	35 (28)	28 (22)	28 (22)	*G35LG1
1500	40 (32)	40 (32)	32 (26)	32 (26)	*G40LG1
1500	45 (36)	45 (36)	36 (29)	36 (29)	*G45LG1
1500	50 (40)	50 (40)	40 (32)	40 (32)	*G50LG1
1500	60 (48)	60 (48)	48 (38)	48 (38)	*G60LG1
1500	70 (56)	67 (54)	56 (45)	54 (43)	*G70LG1
1500	80 (64)	80 (64)	64 (51)	64 (51)	*G80LG1
1500	100 (80)	100 (80)	80 (64)	80 (64)	*G100LG1
1500	—	130 (104)	—	104 (83)	*G130LG1
1500	—	150 (120)	—	120 (96)	*G150LG1
1500	—	175 (140)	—	140 (112)	*G175LG1
1500	—	200 (160)	—	160 (128)	*G200LG1
1500	—	230 (184)	—	184 (147)	*G230LG1
1500	—	250 (200)	—	200 (160)	*G250LG1

*Ratings at 0.8 pf and 25° C (77° F)

**Ratings at 1.0 pf and 25° C (77° F)

GAS

60 Hz – INTERNATIONAL

OLYMPIAN INTERNATIONAL 60 Hz GAS RATINGS: 25 ekW – 250 ekW

60 Hz					
RPM	Standby ekW (kVA)		Prime ekW (kVA)		Generator Set Model
	LP	NG	LP	NG	
Single Phase Output					
1800	25 (25)	25 (25)	—	—	**G25LTA2
1800	35 (35)	35 (35)	28 (28)	28 (28)	**G35LG1
1800	40 (40)	40 (40)	32 (32)	32 (32)	**G40LG1
1800	45 (45)	45 (45)	36 (36)	36 (36)	**G45LG1
1800	50 (50)	50 (50)	40 (40)	40 (40)	**G50LG1
1800	60 (60)	60 (60)	48 (48)	48 (48)	**G60LG1
1800	70 (70)	67 (67)	56 (56)	54 (54)	**G70LG1
1800	80 (80)	80 (80)	64 (64)	64 (64)	**G80LG1
1800	100 (100)	100 (100)	80 (80)	80 (80)	**G100LG1
1800	—	130 (130)	—	104 (104)	**G130LG1
1800	—	150 (150)	—	120 (120)	**G150LG1
1800	—	175 (175)	—	140 (140)	**G175LG1
1800	—	200 (200)	—	160 (160)	**G200LG1
Three Phase Output					
1800	25 (31)	25 (31)	—	—	*G25LTA2
1800	35 (44)	35 (44)	28 (35)	28 (35)	*G35LG1
1800	40 (50)	40 (50)	32 (40)	32 (40)	*G40LG1
1800	45 (56)	45 (56)	36 (45)	36 (45)	*G45LG1
1800	50 (63)	50 (63)	40 (50)	40 (50)	*G50LG1
1800	60 (75)	60 (75)	48 (60)	48 (60)	*G60LG1
1800	70 (88)	67 (84)	56 (70)	54 (68)	*G70LG1
1800	80 (100)	80 (100)	64 (80)	64 (80)	*G80LG1
1800	100 (125)	100 (125)	80 (100)	80 (100)	*G100LG1
1800	—	130 (163)	—	104 (130)	*G130LG1
1800	—	150 (188)	—	120 (150)	*G150LG1
1800	—	175 (219)	—	140 (175)	*G175LG1
1800	—	200 (250)	—	160 (200)	*G200LG1
1800	—	230 (288)	—	184 (230)	*G230LG1
1800	—	250 (313)	—	200 (250)	*G250LG1

*Ratings at 0.8 pf and 25° C (77° F)

**Ratings at 1.0 pf and 25° C (77° F)

12 GAS

GAS

60 Hz – NORTH AMERICA

OLYMPIAN NORTH AMERICA 60 Hz GAS RATINGS: 25 ekW

LTA MODELS (STANDARD)

RPM	ekW – NG	ekW – LP	Generator Set Model
Single Phase Output			
1800	25	25	G25LTA2

OLYMPIAN NORTH AMERICA 60 Hz GAS RATINGS: 35 ekW – 200 ekW

LG MODELS (CUSTOMIZABLE)

RPM	ekW – NG	ekW – LP	Generator Set Model
Single Phase Output			
1800	35	35	G35LG2
1800	40	40	G40LG2
1800	45	45	G45LG2
1800	50	50	G50LG2
1800	60	60	G60LG2
1800	64	67	G70LG2
1800	80	80	G80LG4
1800	100	100	G100LG4
3000	117	130	G130LG2
3600	137	144	G150LG2
1800	150	—	G150LG4
1800	175	—	G175LG4
1800	200	—	G200LG4

GAS

60 Hz – NORTH AMERICA

OLYMPIAN NORTH AMERICA 60 Hz GAS RATINGS: 25 ekW

LTA MODELS (STANDARD)

RPM	ekW – NG	ekW – LP	Generator Set Model
Three Phase Output			
1800	25	25	G25LTA2

OLYMPIAN NORTH AMERICA 60 Hz GAS RATINGS: 35 ekW – 300 ekW

LG MODELS (CUSTOMIZABLE)

RPM	ekW – NG	ekW – LP	Generator Set Model
Three Phase Output			
1800	35	35	G35LG2
1800	40	40	G40LG2
1800	45	45	G45LG2
1800	50	50	G50LG2
1800	60	60	G60LG2
1800	67	70	G70LG2
1800	80	80	G80LG4
1800	100	100	G100LG4
3000	122	130	G130LG2
3600	142	150	G150LG2
1800	150	—	G150LG4
1800	175	—	G175LG4
1800	200	—	G200LG4
1800	230	—	G230LG4
1800	250	—	G250LG4
2300	275	—	G275LG2
2300	300	—	G300LG2

GAS

RATINGS DEFINITIONS

GAS RATINGS DEFINITIONS

Standby Rating

These ratings are applicable to variable loads for the duration of a power outage. There is no overload capability for this rating. Ratings are in accordance with ISO 3046-1.

Gas Rating

Ratings based on LPG fuel and may derate with natural gas. Please contact dealer for natural gas rating.



CONVERSIONS

RATINGS GUIDE

Day T

Tank S

x Hour
+ Rese

OR

Rule

0.056 x
0.27 x

Note: A
engine

On-S

Based

- Elect
600
(Air
Use
(2 p

Refrig

- One
- One
- One
- Auxil

Ice P

- Com

Air C

- hp =
Incr
Dec

CONVERSIONS

REFERENCE

FUEL SYSTEM – DIESEL

Day Tank Sizing

$$\text{Tank Size (gal)} = \frac{\text{Rated BSFC (lb/hp}\cdot\text{hr)}}{7.076 \text{ (lb/gal)}} \times \text{Rated HP} \times \text{Load Factor}$$

x Hours Between Refilling
+ Reserve Requirement

OR

Rule of Thumb for tank size with 25% reserve

$$0.056 \times \text{Ave. BHP demand} \times \text{Hours between refills} \times 1.25 = \text{_____ gal.}$$

$$0.27 \times \text{Ave. BkW demand} \times \text{Hours between refills} \times 1.25 = \text{_____ liters.}$$

Note: Additional tank capacity required for cooling of recirculated fuel in unit-injected engines. Tank should be located below level of injectors or nozzles.

On-Site Power Requirements

Based on 100,000 sq ft. of office bldg., etc and 40°N. Latitudes

- | | |
|----------------------------------|-----------------------------------|
| • Electric Requirements | • Air Conditioning and Compressor |
| 600 kW continuous load | 400 tons prime load |
| (Air conditioning is absorption) | Use two – 200 hp engines |
| Use three – 300 kW units | (No Standby) |
| (2 prime and 1 standby) | |

Refrigeration

- One ton refrigeration = 200 Btu/min = 12,000 Btu/h
- One Boiler hp = 33,475 Btu/h
- One ton compressor rating = One engine hp
- Auxiliary air conditioning equipment requires 1/4 hp/ton of compressor rating

Ice Plant

- Complete power requires 4-5 hp per daily ton capacity

Air Compressor

- hp = 1/4 x cu ft m/min at 100 psi
- Increase bhp 10% for 125 psi
- Decrease bhp 10% for 80 psi

CONVERSIONS

REFERENCE

ELECTRICAL TABLES

To Obtain Alternating Current		
	Single Phase	Three-Phase	Direct Current
Kilowatts	$\frac{V \times I \times P.F.}{1000}$	$\frac{1.732 \times V \times I \times P.F.}{1000}$	$\frac{V \times I}{1000}$
kVA	$\frac{V \times I}{1000}$	$\frac{1.732 \times V \times I}{1000}$	
Horsepower required when kW known (Generator)	$\frac{kW}{.746 \times \text{EFF. (Gen)}}$	$\frac{kW}{.746 \times \text{EFF. (Gen)}}$	$\frac{kW}{.746 \times \text{EFF. (Gen)}}$
kW input when HP known (Motor)	$\frac{HP \times .746}{\text{EFF. (Motor)}}$	$\frac{HP \times .74}{\text{EFF. (Motor)}}$	$\frac{HP \times .74}{\text{EFF. (Motor)}}$
Amperes when HP known	$\frac{HP \times .746}{V \times P.F. \times \text{EFF.}}$	$\frac{HP \times .746}{1.732 \times V \times \text{EFF.} \times P.F.}$	$\frac{HP \times .746}{V \times \text{EFF.}}$
Amperes when kW known	$\frac{kW \times 100}{V \times P.F.}$	$\frac{kW \times 100}{1.732 \times V \times P.F.}$	$\frac{kW \times 100}{V}$
Amperes when kVA known	$\frac{kVA \times 1000}{V}$	$\frac{kVA \times 1000}{1.732 \times V}$	
Frequency (c.p.s)	$\frac{\text{Poles} \times \text{RPM}}{120}$	$\frac{\text{Poles} \times \text{RPM}}{120}$	
Reactive kVA (kVAR)	$\frac{V \times I \times \sqrt{1-(P.F.)^2}}{1000}$	$\frac{1.732 \times V \times I \times \sqrt{1-(P.F.)^2}}{1000}$	
% Voltage Regulation	$\frac{100 (V_{NL}-V_{FL})}{V_{FL}}$	$\frac{100 (V_{NL}-V_{FL})}{V_{FL}}$	$\frac{100 (V_{NL}-V_{FL})}{V_{FL}}$

Electrical Table Abbreviations

V – voltage in volts

I – current in amperes

kW – power in kilowatts (actual power)

kVA – kilovolt amperes (apparent power)

HP – horsepower

RPM – revolutions per minute

kVAR – reactive kilovolt amperes

EFF. – efficiency as a decimal factor

NL – no load

FL – full load

P.F. – power factor

Note: DC kW = DC kVA

18 CONVERSIONS

CONVERSIONS

REFERENCE

THREE PHASE CONNECTION SYSTEMS

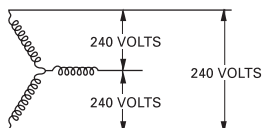

THREE-PHASE, THREE-WIRE (WYE)
A

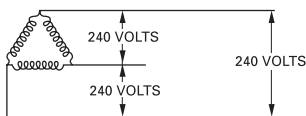

THREE-PHASE, THREE-WIRE (DELTA)
B

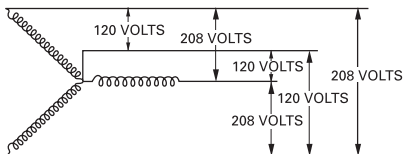

THREE-PHASE, FOUR-WIRE (WYE)
C

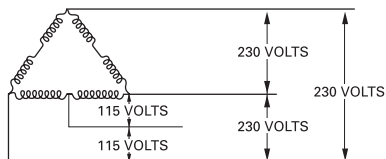

THREE-PHASE, FOUR-WIRE (DELTA)
D

CONVERSIONS

REFERENCE

REDUCED VOLTAGE STARTERS

Type of Starter	Motor Voltage (% Line Voltage)	Line Current (% Full Voltage) Starting Current	Starting Torque (% of Full Voltage) Starting Torque
Full Voltage Starter	100	100	100
Auto Transformer • 80% Tap • 65% Tap • 50% Tap	80 65 50	68 46 30	64 42 25
Resistor Starter Single Step (adjusted for motor voltage to be 80% of line voltage)	80	80	64
Reactor • 50% Tap • 45% Tap • 37.5% Tap	50 45 37.5	50 45 37.5	25 20 14
Part Winding (low speed motors only) • 75% Winding • 80% Winding	100 100	75 50	75 50

Character

Starting
at Same
Terminal

Starting
Factor

Power D
Line Dur

Torque

Smooth
of Accel

Relative

Ease of

Mainten

Line Dist

* Resist
includ
resisto

20 CONVERSIONS

CONVERSIONS

REFERENCE

COMPARISON OF REDUCED VOLTAGE STARTING METHODS

Characteristics	Autotransformer	Primary Resistor	Reactor	Two-Step
Starting Line Current at Same Motor Terminal Voltage	Least	More than autotransformer type		
Starting Power Factor	Low	*High	Low	Low
Power Draw from Line During Starting	Low	More than autotransformer type		
Torque	Increases slightly with speed	Increases rapidly with speed		Increases slightly with speed
Smoothness of Acceleration	Motor momentarily disconnected from line from start to run	Smooth. Transfer made with little change in motor terminal voltage		Smooth
Relative Cost	Average	Lower in small size-otherwise equal	Average	Less than others
Ease of Control	Same	Same	Same	No provision for adjustment of starting current
Maintenance	Same	Same	Same	Less than others
Line Disturbance	Varies with conditions and type of load			More than others

* Resistor starting adds considerable kW load to generator set. Total power required includes the motor kW and the kW which is lost as heat in the resistor. The series resistors account for a higher than normal starting power factor.

CONVERSIONS

REFERENCE

ENGINE ROOM VENTILATION

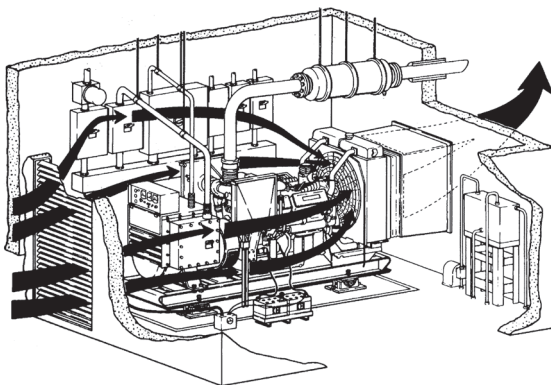

Engine room ventilation can be estimated by the following formulas, assuming 100° F (38° C) ambient air temperature:

$$V \text{ (cfm)} = \frac{H}{0.070 \times 0.24 \times \Delta T} + \text{Engine Combustion Air}$$

$$V \text{ (m}^3\text{/min)} = \frac{H}{1.099 \times 0.017 \times \Delta T} + \text{Engine Combustion Air}$$

V = Ventilation air (cfm) (m³/min).

H = Heat radiation (Btu/min) (kW).

ΔT = Permissible temperature rise in engine room (°F) (°C).

Density of air at 100° F = 0.070 lb/cu ft (1.099 kg/m³).

Specific heat of air = 0.24 Btu/°F (0.017 kW/°C).

CONVERSIONS

REFERENCE

CONVERSION FACTORS

LENGTH

Unit	mm	in	ft	yd	m	km	mi
mm	1	0.03937	0.003281	0.001094	0.001	0.000001	—
in	25.4	1	0.08333	0.02778	0.0254	0.000025	—
ft	304.8	12	1	0.33333	0.3048	0.000305	—
yd	914.4	36	3	1	0.9144	0.000914	—
m	1000	39.3701	3.28084	1.09361	1	0.001	0.00062
km	1000000	39370.1	3280.84	1093.61	1000	1	0.62137
mi	1609344	63360	5280	1760	1609.34	1.60934	1

AREA

Unit	mm ²	in ²	m ²	ft ²
mm ²	1	0.00155	—	—
in ²	645.16	1	0.000645	0.006944
m ²	1000000	1550	1	10.76391
ft ²	92903	144	0.0929	1

1 sq mile = 640 acres 1 cir mil = 7.854 x 10⁻⁷in²
 1 cir mil = 5.067 x 10⁻⁶cm² 1 acre = 4840 yd²
 1 cir mil = 0.7854 x mils²

WEIGHT

Unit	Kilograms	Ounces Avoirdupois	Pounds Avoirdupois	Short	Tons Long	Metric
Kilograms	1	35.274	2.2046	—	—	—
Ounces Avoirdupois	0.02835	1	0.0625	—	—	—
Pounds Avoirdupois	0.45359	16	1	—	—	—
Short Ton	907.185	32000	2000	1	0.8929	0.9072
Long Ton	1016.05	35840	2240	1.12	1	1.0160
Metric Ton	1000	35274	2204.62	1.1023	0.9842	1

1 grain = 0.064799 gram

CONVERSIONS

REFERENCE

CONVERSION FACTORS

FLOW

Unit	U.S. gal/min	million U.S. gal/day	ft ³ /s	m ³ /h	L/s
U.S. gal/min	1	0.001440	0.00223	0.2270	0.0631
1 million gal/day	694.5	1	1.547	157.73	43.8
ft ³ /s	448.8	0.0646	1	101.9	28.32
m ³ /h	4.403	0.00634	0.00981	1	0.2778
L/s	15.85	0.0228	0.0353	3.60	1

MCFD = 1000 ft³/day

MMCFD = 1,000,000 ft³/day

lb/bhp-hr x 607.73 = g/kW-hr

ENERGY

Unit	Btu	Cal	ft-lb	J	Kcal	Therm
Btu	1	252	778	1055.056	0.252	0.00001
Calorie	0.00397	1	3.08866	4.187	0.001	—
Foot-Pound	0.001285	0.323765	1	1.356	0.003089	—
Joule	0.000948	0.23895	0.73745	1	—	—
Kilocalorie	3.96825	1000	3089	4185	1	2.519
Therm	100000	396.8254	128.5347	94.78169	0.39682	1

1 Therm = 1,000,000 Btu

Btu/ft³ = 8.899 kg-cal/m³

Btu/ft²/min = 0.1220 Watts/in²

Btu/lb = 0.5556 kg-cal/kg

CONVERSIONS

REFERENCE

CONVERSION FACTORS

TEMPERATURE CONVERSION

$$^{\circ}\text{F} = (1.8 \times ^{\circ}\text{C}) + 32$$

$$^{\circ}\text{C} = 0.5555 (^{\circ}\text{F} - 32)$$

ANGLE

$$1 \text{ quadrant} = 90 \text{ degrees}$$

$$1 \text{ quadrant} = 1.57 \text{ radians}$$

$$1 \text{ radian} = 57.3 \text{ degrees}$$

$$1 \text{ degree} = 60 \text{ minutes}$$

$$1 \text{ minute} = 2.9 \times 10^{-4} \text{ radians}$$

IDENTIFYING CODE LETTERS

ON AC MOTORS

NEMA Code Letter	Starting skVA/hp
A	0.00 – 3.14
B	3.15 – 3.54
C	3.55 – 3.99
D	4.00 – 4.49
E	4.50 – 4.99
F	5.00 – 5.59
G	5.60 – 6.29
H	6.30 – 7.09
J	7.10 – 7.99
K	8.00 – 8.99
L	9.00 – 9.99
M	10.00 – 11.19
N	11.20 – 12.49
P	12.50 – 13.99
R	14.00 – 15.99
S	16.00 – 17.99
T	18.00 – 19.99
U	20.00 – 22.39
V	22.40

Note: Code letters apply to motors up to 200 HP.

CONVERSIONS

REFERENCE

CONVERSION FACTORS

VOLUME AND CAPACITY

Unit	in ³	ft ³	yd ³	mm ³
in ³	1	0.00058	0.00002	16387.1
ft ³	1728	1	0.03704	28320000
yd ³	46656	27	1	764554858
mm ³	6.1×10^{-5}	4.0×10^{-8}	-	1
m ³	61023.7	35.3147	1.30795	1000000000
U.S. gal	231	0.13368	0.00495	3785420
Imp gal	277.419	0.16054	0.00595	4540090
liter	61.0237	0.03531	0.00131	1000000
acre-ft	-	43560	1613.33	-

1 board-foot = 144 in³

1 bushel = 1.244 ft³

1 bushel = 4 pecks

POWER

Unit	Btu/min	ft-lb/min	hp
Btu/min	1	778.2	0.02358
ft-lb/min	0.00128	1	0.00003
Horsepower	42.456	33000	1
Joules/min	0.00095	0.7405	0.0000223
Metric hp	41.827	32550	0.98632
Kilowatt	59	44250	1.34102
Watt	0.05687	44.25	0.00134

PRESSURE AND HEAD

Unit	mm/Hg (0° C)	in./Hg (0° C)	in. H ₂ O (60° F)	ft. H ₂ O (60° F)
mm/Hg	1	0.03937	0.5357	0.04464
in./Hg	25.4	1	13.61	1.134
in. H ₂ O	1.86827	0.07355	1	0.08333
ft. H ₂ O	22.4192	0.88265	12	1
lb/in ²	51.7149	2.03602	27.70	2.309
kg/cm ²	735.559	28.959	395	32.84
bar	750.062	29.530	401.8	33.49
kPa	7.50062	0.29530	4.01835	0.33486

26 CONVERSIONS

CONVERSIONS

REFERENCE

CONVERSION FACTORS

m ³	U.S. gal	Imp gal	liter
0.00002	0.00432	0.00361	0.01639
0.02832	7.48052	5.22883	28.3169
0.76455	201.974	168.178	764.555
—	2.6×10^{-7}	2.2×10^{-7}	1.0×10^{-6}
1	264.192	219.969	1000
0.00378	1	—	3.78541
0.00455	1.20095	1	4.54609
0.001	0.26417	0.21997	1
1233.48	325851	271335	—

J/min	Metric hp	kW	W
1055.000	0.02391	0.0175843	17.5843
1.3504	0.00003	0.0000226	0.0226
44791	1.014	0.74570	745.7
1	0.0000226	0.0000166	0.016668
44127	1	0.73549	735.498
59997	1.35962	1	1000
59.9968	0.00136	0.001	1

lb/in ²	kg/cm ²	bar	Atmospheres	
			101.4 Pa (14.7 psi)	kPa
0.01934	0.00136	0.00133	0.001315	—
0.49115	0.03453	0.03386	0.03342	—
0.03613	0.00254	0.00249	0.00246	0.249
0.43352	0.030479	0.02989	0.02950	2.989
1	0.07031	0.06895	0.06805	6.895
14.2257	1	0.98067	0.96784	98.067
14.504	1.01972	1	0.98692	101.325
0.145038	0.0101972	0.010000	0.00986920	1

PRODUCT SUPPORT

DEFINITIONS

PRODUCT SUPPORT DEFINITIONS

Extended Service Coverage (ESC)

Depending on the engine model and application, Silver, Gold or Platinum coverage levels are available from Caterpillar with terms to meet most applications whether prime or standby.

Equipment	Coverage Option
New engines	New ESC
Used engines	Advantage ESC
Overhauls	OPC*

Electric Power ESC reimburse 100% of the parts at customer list price, labor at selling rates and travel and mileage charges (less any deductibles) for covered repairs.

Available worldwide, ESC provides 100% of usual and customary parts and labor costs for system failures due to defects in materials and workmanship on components over the duration of the covered period.

This is a brief description of Extended Coverage. See your Cat dealer for more information. The Extended Coverage contract will govern.

*Overhaul Protection Coverage



30 NOTES

32 NOTES

For more information or to find your nearest dealer go to:
www.catelectricpowerinfo.com/rg



Exclusively available from your
Cat® Dealer.

For additional information or to find
your nearest dealer go to:

www.catelectricpowerinfo.com/rg

LEXE7581-04

June 2013

© 2013 Caterpillar All Rights Reserved Printed in USA CAT, CATERPILLAR, their respective logos, ACERT, ADEM, "Caterpillar Yellow" and the "Power Edge" trade dress, as well as corporate and product identity used herein, are trademarks of Caterpillar and may not be used without permission.